

Operating
Manual

HP 8757D
Scalar Network Analyzer

Operating Manual

HP 8757D Scalar Network Analyzer

SERIAL NUMBERS

This manual applies directly to any HP 8757D scalar network analyzer having a serial number prefix of 3309A or greater. For instruments with a lower serial number prefix, see "Manual Backdating" chapter in the HP 8757D Service Manual



HP Part No. 08757-90109 Master Set part number 08575-90107
Printed in USA March 1993

Notice.

The information contained in this document is subject to change without notice.

Hewlett-Packard makes no warranty of any kind with regard to this material, including but not limited to, the implied warranties of merchantability and fitness for a particular purpose. Hewlett-Packard shall not be liable for errors contained herein or for incidental or consequential damages in connection with the furnishing, performance, or use of this material.

Certification

Hewlett-Packard Company certifies that this product met its published specifications at the time of shipment from the factory. Hewlett-Packard further certifies that its calibration measurements are traceable to the United States National Institute of Standards and Technology, to the extent allowed by the Institute's calibration facility, and to the calibration facilities of other International Standards Organization members.

Regulatory Information

Chapter [cross reference to location of declaration of conformity & noise information] contains regulatory information.

Warranty

This Hewlett-Packard instrument product is warranted against defects in material and workmanship for a period of one year from date of shipment. During the warranty period, Hewlett-Packard Company will, at its option, either repair or replace products which prove to be defective.

For warranty service or repair, this product must be returned to a service facility designated by Hewlett-Packard. Buyer shall prepay shipping charges to Hewlett-Packard and Hewlett-Packard shall pay shipping charges to return the product to Buyer. However, Buyer shall pay all shipping charges, duties, and taxes for products returned to Hewlett-Packard from another country.

Hewlett-Packard warrants that its software and firmware designated by Hewlett-Packard for use with an instrument will execute its programming instructions when properly installed on that instrument. Hewlett-Packard does not warrant that the operation of the instrument, or software, or firmware will be uninterrupted or error-free.

LIMITATION OF WARRANTY

The foregoing warranty shall not apply to defects resulting from improper or inadequate maintenance by Buyer, Buyer-supplied software or interfacing, unauthorized modification or misuse, operation outside of the environmental specifications for the product, or improper site preparation or maintenance.

NO OTHER WARRANTY IS EXPRESSED OR IMPLIED. HEWLETT-PACKARD SPECIFICALLY DISCLAIMS THE IMPLIED WARRANTIES OF MERCHANTABILITY AND FITNESS FOR A PARTICULAR PURPOSE.

EXCLUSIVE REMEDIES

THE REMEDIES PROVIDED HEREIN ARE BUYER'S SOLE AND EXCLUSIVE REMEDIES. HEWLETT-PACKARD SHALL NOT BE LIABLE FOR ANY DIRECT, INDIRECT, SPECIAL, INCIDENTAL, OR CONSEQUENTIAL DAMAGES, WHETHER BASED ON CONTRACT, TORT, OR ANY OTHER LEGAL THEORY.

Assistance

Product maintenance agreements and other customer assistance agreements are available for Hewlett-Packard products.

For any assistance, contact your nearest Hewlett-Packard Sales and Service Office.

Safety Notes

The following safety notes are used throughout this manual. Familiarize yourself with each of the notes and its meaning before operating this instrument.

Caution



Caution denotes a hazard. It calls attention to a procedure that, if not correctly performed or adhered to, could result in damage to or destruction of the instrument. Do not proceed beyond a *caution* sign until the indicated conditions are fully understood and met.

Warning



Warning denotes a hazard. It calls attention to a procedure which, if not correctly performed or adhered to, could result in injury or loss of life. Do not proceed beyond a *warning* note until the indicated conditions are fully understood and met.

Instruction Manual



The **instruction manual** symbol. The product is marked with this symbol when it is necessary for the user to refer to the instructions in the manual.

General Safety Considerations

Warning



Before this instrument is switched on, make sure it has been properly grounded through the protective conductor of the ac power cable to a socket outlet provided with protective earth contact.

Any interruption of the protective (grounding) conductor, inside or outside the instrument, or disconnection of the protective earth terminal can result in personal injury.

Warning



There are many points in the instrument which can, if contacted, cause personal injury. Be extremely careful.

Any adjustments or service procedures that require operation of the instrument with protective covers removed should be performed only by trained service personnel.

Caution



Before this instrument is switched on, make sure its primary power circuitry has been adapted to the voltage of the ac power source.

Failure to set the ac power input to the correct voltage could cause damage to the instrument when the ac power cable is plugged in.

Contents

Table of Contents

1. General Information	
Safety Considerations	1-2
The HP 8757D Analyzer	1-5
CRT Attributes	1-5
Displays	1-5
Peripherals	1-5
Calibration Data and Instrument States	1-5
Measurement Channels	1-5
Options available	1-5
Local and Remote Operation	1-7
Specifications, General Requirements, and Operating Characteristics	1-8
Manufacturer's Declarations	1-16
Accessories and Supplies	1-20
2. Installation	
Introduction	2-1
Initial Inspection	2-2
Operating Environment	2-3
Electrostatic Discharge	2-4
Power Requirements	2-5
Checking the Line Voltage and Fuse	2-5
Checking the Power Cable	2-6
Equipment Required But Not Supplied	2-7
AC Detection	2-7
Firmware Compatibility	2-7
Rack Mounting	2-8
Connecting the Analyzer to a Source	2-10
External Modulation	2-10
Other Configurations	2-10
Connecting the Analyzer to an External Monitor	2-15
Setting the HP-IB Address	2-15
HP-IB Connectors and Cables	2-16
Storing and Shipping	2-19
Environment	2-19
Packing the Instrument	2-19
Returning an Instrument for Service	2-19

3. Operation	
Revision 5.1	3-2
Local Operation	
HP 8757D User's Guide	
1. Operating	3
2. Transmission Measurements	10
3. Reflection Measurements	17
4. Limit Lines	19
5. Alternate Sweep	21
6. External Disk Save/Recall	23
7. Special Functions	25
A. AC versus DC Detection	26
Index	27
HP 8757D Operating Reference	
1. Front-Panel Features	1-1
2. CHANNEL	2-1
3. ENTRY Area	3-1
4. FUNCTION Keys	4-1
5. INSTRUMENT STATE	5-1
6. Rear Panel Features	6-1
A. Operator's Check	A-1
B. Softkey Menu Structure Maps	B-1
C. Performing an External Calibration	C-1
D. Measurement Applications	D-1
Remote Operation	
HP-IB Programming Notes	1
HP 8757D Quick Reference Guide	1
HP 8757D with HP 90000 Series 200/300 (BASIC)	1
HP 8757D with HP Vectra (QuickBasic 4.5)	1
HP 8757D with HP Vectra (QuickC 2.5)	1
In Case of Difficulty	
Contents	1
Manual Operation	2
Line Power	2
Error Codes	2
System Operation	3
General	3
HP-IB Connections and Addresses	3
Other Cable Connections	4
Remote Operation	4
Inaccurate Operation	5
Calibration	5
Modulation Characteristics	5
Sweep Speed	5
Calibrator Option 002 Only	5
Miscellaneous Problems	6
Alternate Sweep	6
Number of Trace Points and Trace Memory	7

Autozero of DC Detectors	7
Save/Recall Registers	7
System Interface On/Off	8
Measurement-Memory-Memory	9
Cursor Search	9
On-Site Service	9
Main Error Codes	10
Power Calibration Error Messages	13
Detector Error Messages (HP 85037A/B only)	14
On-Site Service - Calibration	14
Connector Care	
1. Introduction	1-1
2. Visual Inspection and Cleaning	2-1
3. Mechanical Inspection and Connecting	3-1
A. Center Conductor Collets	A-1
B. Accessories and Cleaning Supplies	B-1
Index	Index-1

Glossary

General Information

This chapter provides information on the following topics:

- safety considerations
- serial numbers
- analyzer description
- power calibrator option
- available options
- specifications
- operating characteristics
- manufacturer's radio interference declaration
- manufacturer's ISO declaration
- manufacturer's sound emission declaration
- ordering accessories and supplies

Safety Considerations

General

This product was designed and manufactured in accordance with international safety standards. Before you operate this analyzer, review the product and related documentation. Become familiar with safety markings and instructions.

Safety Symbols



Instruction manual symbol: the product will be marked with this symbol when it is necessary for the user to refer to the instruction manual (refer to Table of Contents).



Indicates hazardous voltages.



Indicates earth (ground) terminal.

Warning



The **WARNING** sign denotes a hazard. It calls attention to a procedure, which, if not correctly performed or adhered to, could result in personal injury. Do not proceed beyond a **WARNING** sign until the indicated conditions are fully understood and met.

Caution



The **CAUTION** sign denotes a hazard. It calls attention to an operating procedure, which, if not correctly performed or adhered to, could result in damage to or destruction of part or all of the product. Do not proceed beyond a **CAUTION** sign until the indicated conditions are fully understood and met.

Safety Earth Ground

This is a Safety Class I product (provided with a protective earthing terminal). An uninterruptible safety earth ground must be provided from the main power source to the product input wiring terminals, power, cord, or supplied power cord set. Whenever it is likely that the protection has been impaired, the product must be made inoperative and secured against any unintended operation.

Before Applying Power

Verify that the product is configured to match the available main power source. Refer to the input power configuration instructions provided in this manual.

If this product is to be used with an autotransformer make sure the common terminal is connected to the neutral (grounded) side of the main supply.

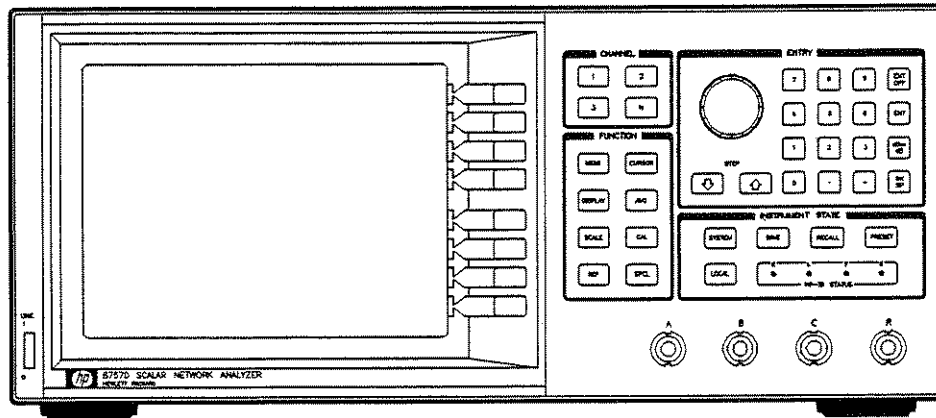

HP 8757D OPTION 001 SCALAR NETWORK ANALYZER

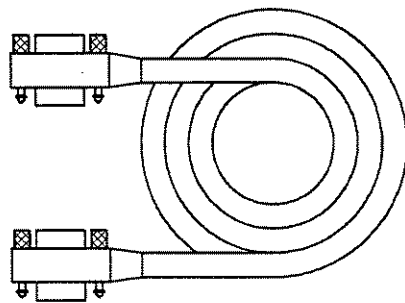

HP-IB CABLE

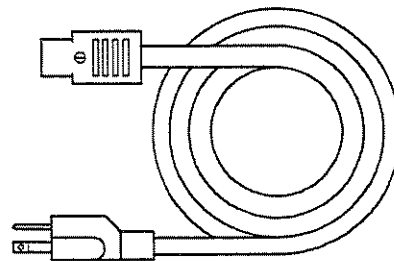

POWER CABLE*

* Power cable/plug supplied depends on country of destination.

Figure 1-2. HP 8757D Scalar Network Analyzer and Accessories Supplied

The HP 8757D Analyzer

The HP 8757D (Figure 1-2) is a microprocessor-based receiver capable of making scalar (magnitude only) reflection and transmission measurements. The external detectors used determine the frequency range. The raster display provides high resolution for viewing measurements.

CRT Attributes

The CRT displays attributes (such as the grid, measurement traces for each channel, and labels) in factory-defined colors. You can adjust the hue, saturation and intensity of each of these attributes.

Displays

The analyzer can simultaneously drive both the internal display and one external monitor (color or monochrome, if compatible with the analyzer's scan rate and video levels).

Peripherals

You can use the analyzer to control external printers, plotters, and sources through the system interface. A printer and plotter buffer speeds measurements by returning control to the analyzer while data prints.

Calibration Data and Instrument States

You can store and recall instrument states and calibration data to and from external disks.

Measurement Channels

Four independent but identical measurement channels allow simultaneous measurements and viewing of measurement parameters. The detector inputs (A, B, C, and R) accept AC or DC detected signals from detectors or bridges.

Options available

- Option 001 adds a fourth detector input (C).
- Option 002 adds the power calibrator.
- Option 001/002 adds *both* the fourth detector input and the power calibrator. (See the front panel options table on the following page and the descriptions below it for more detailed information on these options.)

HP 8757 FRONT PANEL OPTIONS

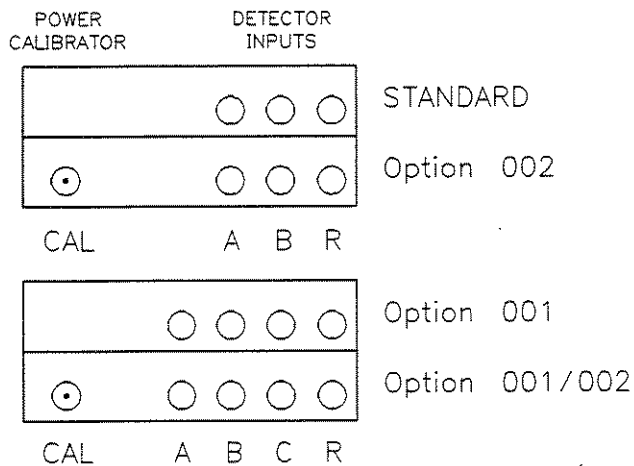

Figure 1-3.

Option 001, Fourth Detector Input

This option supplies four front-panel detector inputs (A, B, C, and R).

Option 002, Internal Power Calibrator

This option supplies three front panel detector inputs (A,B,and R) and adds an internal power calibrator. The power can be precisely controlled in 1 dB increments from +20 to -50 dBm.

Option 001/002

This option supplies both a fourth detector input, as well as the internal power calibrator.

Option 802, HP-IB Disk Drive

This option adds one HP 9122 dual disk drive (3.5 inch), and one HP 10833A HP-IB cable (1m (3.3 ft)).

Option 908, Rack Mount Without Handles

This option supplies a rack mount kit containing a pair of flanges and the necessary hardware to mount the analyzer (with handles *detached*) in an equipment rack that has 482.6 mm (19 in) horizontal spacing. See chapter 2 for installation instructions.

Option 910, Extra Documentation Set

This option supplies a *second* set of analyzer documentation (one operating manual and one service manual).

Option 913, Rack Mount With Handles

This option supplies a rack mount kit containing a pair of flanges and the necessary hardware to mount the analyzer (with handles *attached*) in an equipment rack that has 482.6 mm (19 in) horizontal spacing. See chapter 2 for installation instructions.

Option OD2, Factory Refurbished Demonstration Instrument

These instruments (designated by a yellow option tag on the serial number label) have been used as demonstration units for less than 12 months, then returned to the factory for electrical and mechanical refurbishment. The standard warranty and specifications apply.

Option W03, On-Site Service

This option (identified on the serial number tag) converts the normal one-year return-to-HP warranty to a 90-day on-site warranty. You can order this option only at time-of-purchase.

Option W30, Extended Service

This option (identified on the serial number tag) adds two additional years of return-to-HP hardware support following the first year of warranty. You can order this option only at time-of-purchase.

Option W32, Three-Year Calibration

This option (identified on the serial number tag) provides a three-year return-to-HP calibration service. You can order this option only at time-of-purchase.

Option 1BN, MIL-STD 45662A Calibration

This option provides an instrument calibration and a certificate of calibration in full compliance with MIL-STD 45662A.

Option 1BP, MIL-STD 45662A Calibration with Data

This option provides an instrument calibration, a certificate of calibration, and test data in full compliance with MIL-STD 45662A.

Local and Remote Operation

You can operate the analyzer either locally, using the front panel controls and menu selections, or remotely over the HP-IB. You can also generate on-screen graphics (see “Remote Operation”).

Specifications, General Requirements, and Operating Characteristics

Specifications

Specifications (listed in Table 1-1) are the performance standards or limits against which the instrument is tested. Specifications apply from +20°C to +30°C (unless otherwise noted), and only after the instrument's temperature stabilizes after one hour of continuous operation. Unless otherwise noted, corrected limits are given when specifications are subject to optimization with error-correction routines.

General Requirements

General requirements (listed in Table 1-2) define specifications required of the source for proper analyzer operation.

Operating Characteristics

Operating characteristics (listed in Table 1-3) are non-warranted parameters. They are not specifications, but are typical performance parameters that most units meet from +20°C to +30°C.

Table 1-1. HP 8757D Specifications¹ (1 of 2)

Function: Four independent display channels process signals from the HP 85025, 85026, 11664, or 85037 detectors and the HP 85020 or 85027 bridges. The analyzer displays the data logarithmically, in single input or ratio mode, with respect to frequency, on the internal CRT. Three detector inputs (A, B, and R) accept AC or DC detected signals from detectors or bridges.

Option 001 has four detector inputs (A, B, C, and R).

Modulator Drive: The analyzer modulator drive output provides the circuitry to drive the HP 8340 and 8341 synthesized sweepers and the HP 11665B modulator. You can turn modulator drive on and off via either the front panel or HP-IB. In the OFF state, the modulator drive signal turns the HP 11665B fully on for minimum insertion loss.

Marker Accuracy: The marker frequency accuracy is 0.1 PMM of the marker frequency plus the source marker frequency accuracy.

Frequency: 27.778 kHz \pm 12 Hz
Symmetry: 50% \pm 1%

Dynamic Range, Dynamic Accuracy, Absolute Power Accuracy: These system specifications are dependent on the detector used. The following examples show both the HP 85037A/B and the HP 11664A/E detectors. (For HP 85025 and HP 85026 specifications, refer to their manuals.)

Dynamic Range²

HP 85037A/B
 AC Mode: +20 to -55 dBm
 DC Mode: +20 to -50 dBm

HP 11664A/E
 AC Mode: +16 to -60 dBm

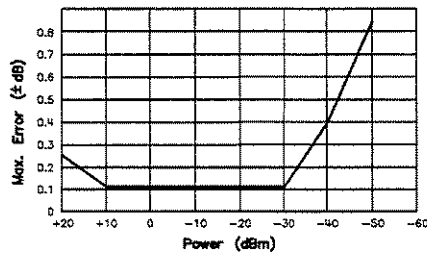

Dynamic Accuracy - AC/DC MODE
 Absolute Accuracy - DC MODE
 (D.C. MODE to -50dBm only)

HP 85037A/B

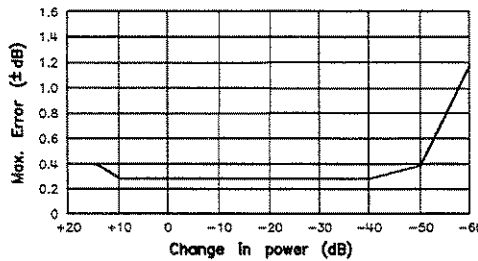

Note: For \leq 20dB change of power within +10 to -40dBm the specifications for the HP8757D with the HP11664A/E is $\pm(0.1dB+0.01dB/dBm)$.

HP 11664A/E

¹All specification apply at 25° \pm 5°C, unless otherwise noted.

²Using an HP 85037A/B Detector.

HP 8757D Specifications¹ (2 of 2)

Power Calibrator (Option 002)

The internal power calibrator option (Option 002) provides a 50 MHz reference standard for characterizing the absolute power accuracy and dynamic power accuracy of HP 85037 Series precision detectors.

Frequency: 50 MHz \pm 0.1 MHz

Output Power (DC mode):

Range: +20 to -50 dBm
Accuracy at 0 dBm: \pm 0.05 dB

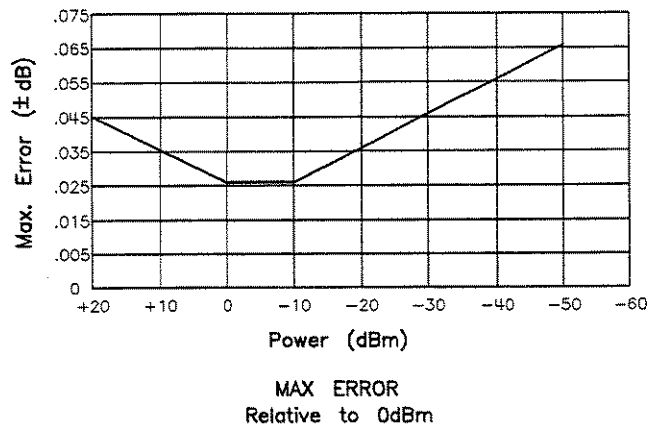

SWR: \leq 1.05 typical

Modes of Operation:

DC Mode (unmodulated)

AC Mode:

Modulation Frequency: 27.778 \pm 0.012 kHz

On/Off Ratio: \geq 40 dB typical

Symmetry: 50 \pm 1% typical

Connector: Type-N(f)

Accessories Included:

Adapter: Type-N(m) to 3.5 mm(f)

¹All specification apply at 25° \pm 5°C, unless otherwise noted.

Table 1-2. HP 8757D General Requirements

General requirements define specifications required of the source for proper analyzer operation.

Sweep Time: Minimum sweep time and maximum number of displayed CRT traces depend on the horizontal resolution (number of points):

Number of Points	Minimum Sweep Time (ms) ¹			
	1 Input	2 Inputs	3 Inputs	4 Inputs
101	40	40	40	40
201	40	40	52	68
401	40	72	104	136
801	80	144	208	272
1601	160	288	NA	NA

Modulation (for use with HP 85025, 85026, 11664, 85037 detectors and HP 85020 or 85027 bridges in AC mode):

- Square-wave amplitude modulation.
- Frequency: 27.778 kHz ±20 Hz.
- ≥30 dB on/off ratio.
- 45% to 55% symmetry.

Sweep Voltage (Sweep In): Horizontal sweep voltage (0 to 10 V) or a pulse signal (0 to 10 V) from an HP 83750 Series source provided to the analyzer's SWEEP IN 0—10V rear-panel input. You can use other sweep voltages by using the analyzer's non-standard sweep mode.

Marker and Marker Blanking (Poz Z Blank): Blanking and marker signals provided to the analyzer's POS Z BLANK rear-panel input. HP 8350, HP 8340 and 8341, and HP 8360 Series sources provide five available markers, but the HP 83750 Series source provides ten available markers.

	Voltage Levels (Typical)
Blanked	+5 V
Unblanked	0 V
Marker	-4 V
Active Marker	-8 V

¹Log magnitude format.

Table 1-3. Operating Characteristics¹ (1 of 4)

Display			
<p>Display Modes: All analyzer channels can display any detector input, or any ratio combination of detector inputs. The CRT can display data in one of the following modes.</p> <p>Log Magnitude:</p> <p> dBm: Single channel power measurement.</p> <p> dB: Relative power measurement (ratio or relative to trace memory).</p> <p> SWR: Relative measurements.</p> <p> AUX: The rear-panel BNC input ADC IN can be measured and displayed in volts (−10 to +10V). Typical maximum error is 60 mV.</p>			
Display Mode	Scale Resolution	Display Range	Vertical Resolution
dBm	0.1 to 20 dB/div	−80 to −130 dBm ²	0.003 dB ³
dB (ratio)	0.1 to 20 dB/div	−150 to +150 dBm ⁴	0.006 dB ³
Normalized Ratio	0.1 to 20 dB/div	−180 to +180 dB	0.01 dB
SWR	0.02 to 10 units/div	1.0 to 37.0	0.01 at 1 0.1 at 10 0.27 at 30
AUX	0.025 to 5V/div	−10 to +10V	0.001 V
<p>Color Settings: Up to 8 operator-selected colors for CRT attributes (such as the grid, measurement traces, and labels).</p>			

¹The values in this table are *not* specifications, but typical, non-warranted performance parameters.

²Maximum 90 dB range per trace.

³0.01 dB for display cursor.

⁴Maximum 180 dB range per trace.

Table 1-3. Operating Characteristics¹ (2 of 4)

Display(cont'd)	
Horizontal Resolution:	
Number of Traces	Number of Points
1	101, 201, 401, 801, 1601
2	101, 201, 401, 801
3, 4	101, 201, 401
Averaging: 2, 4, 8, 16, 32, 64, 128, or 256 successive traces.	
Smoothing: Provides a linear moving average of adjacent data points. The smoothing aperture defines the trace width (number of data points) averaged, and ranges from 0.1% to 20% of the trace width.	
Normalization: Traces are stored and normalized with the highest resolution, independent of display scale/division or offset.	
Calibration data is interpolated when you decrease the frequency span with adaptive normalization engaged.	
Limit Lines: Any limit combination of flat or sloped lines, or single points (up to 12 segments) can be displayed on channels 1 and 2. You can store limit lines in save/recall registers 1 through 4.	
Graticules:	8 vertical x 10 horizontal divisions. 1 division \approx 11 mm.

¹The values in this table are *not* specifications, but typical, non-warranted performance parameters.

Table 1-3. Operating Characteristics¹ (3 of 4)

CRT and Graphics											
<p>CRT Scan Rate: Raster scan with 60 Hz vertical refresh rate, and 25.5 kHz horizontal scan rate.</p> <p>Graphics Resolution: 1024 horizontal x 400 vertical pixels.</p>											
Rear Panel Connectors											
<p>ADC IN: An auxiliary voltage input (-10 to +10V) that can be displayed (in volts) on any channel.</p> <p>Control 1 and 2: Provide digital output signals (TTL open-collector) to drive peripheral equipment in an HP-IB controlled system.</p> <p>DAC Out: Used in troubleshooting.</p> <p>Modulator Drive: Provides the drive for HP 8340/8341 synthesized sweepers and the HP 11665B modulator. You can turn modulator drive on/off at the front panel or by HP-IB.</p> <p>Pos Z Blank Input:</p> <table style="margin-left: 100px;"> <thead> <tr> <th></th> <th style="text-align: center;">Voltage Levels</th> </tr> </thead> <tbody> <tr> <td>Blanked:</td> <td style="text-align: center;">+5 V</td> </tr> <tr> <td>Unblanked:</td> <td style="text-align: center;">0 V</td> </tr> <tr> <td>Marker:</td> <td style="text-align: center;">-4 V</td> </tr> <tr> <td>Active Marker:</td> <td style="text-align: center;">-8 V</td> </tr> </tbody> </table> <p>Stop Sweep: Used with HP 8350 sweep oscillators and HP 8340, 8341, or 8360 synthesized sweepers (when controlled by the HP 8757 system interface) to stop the sweep at band crossings and at the end of sweep.</p> <p>Sweep In: Accepts the horizontal sweep voltage (usually provided by the source).</p> <p>Video Output: Three BNC connectors used to drive external monitors with the following characteristics:</p> <ul style="list-style-type: none"> 75Ω input impedance. R, G, B, with sync on green. 60 Hz verticle refresh rate. 25.5 kHz horizontal scan rate. 1 Vp-p (0.7 V = white; 0 V = black; -0.3 V = sync). 			Voltage Levels	Blanked:	+5 V	Unblanked:	0 V	Marker:	-4 V	Active Marker:	-8 V
	Voltage Levels										
Blanked:	+5 V										
Unblanked:	0 V										
Marker:	-4 V										
Active Marker:	-8 V										

¹The values in this table are *not* specifications, but typical, non-warranted performance parameters.

Table 1-3. Operating Characteristics¹ (4 of 4)

HP-IB		
Interface: HP-IB operates according to IEEE 488-1978 and IEC-625 interface standards.		
Interface Function Codes: SH1, AH1, T6, TE0, L4, LE0, SR1, RL1, PP0, DC1, DT0, C0, E1.		
Transfer Formats: You may transfer data either as ASCII characters, or as 16-bit integers (most significant byte first). You may take readings at a single point, or transfer an entire trace at once.		
Transfer Speed (includes command to initiate output):		
Format	# Points	ms (typical)
ASCII	401	500
ASCII	1	10
Binary	401	30
Binary	1	7
Programmable Functions: Except for power on/off, all front panel functions are programmable. The analyzer is compatible with all appropriate HP 8757A/C/E programming codes.		
Interrupts: The following conditions generate HP-IB service interrupts (SRQs):		
Front panel key pressed		Illegal command
Instrument self-test error		Limit test fails
Operation (sweep or plot) completes		
System Interface		
The 8757 system interface is a dedicated HP-IB port used exclusively by the analyzer to control and extract information from a swept source, digital plotter, printer, or other device.		
General		
Temperature Range:	Operating:	0° to +55°C (+32° to 131°F).
	Storage:	-40° to +70°C (-40° to +158°F).
Power Requirements: 48 to 66 Hz, 100/120/220/240 V ±10%, typically 155 VA.		
Dimensions: 178 x 425 x 445 mm (7.0 x 16.75 x 17.5 in).		
Weight:	Net:	22 kg (48 lb)
	Shipping:	28 kg (61.5 lb)

¹The values in this table are *not* specifications, but typical, non-warranted performance parameters.

Manufacturer's Declarations

RADIO FREQUENCY INTERFERENCE

Note



This is to certify that this product meets the radio frequency interference requirements of Directive FTZ 1046/1984. The German Bundespost has been notified that this equipment was put into circulation and has been granted the right to check the product type for compliance with these requirements.

Note: If test and measurement equipment is operated with unshielded cables and/or used for measurements on open set-ups, the user must ensure that under these operating conditions, the radio frequency interference limits are met at the border of his premises.

Model HP 8757D

Note



Hiermit wird bescheinigt, dass dieses Gerät/System in Übereinstimmung mit den Bestimmungen von Postverfügung 1046/84 funkentstört ist.

Der Deutschen Bundespost wurde das Inverkehrbringen dieses Gerätes/Systems angezeigt und die Berechtigung zur Überprüfung der Serie auf Einhaltung der Bestimmungen eingeräumt.

Zustzinformation für Mess-und Testgeräte:

Werden Mess- und Testgeräte mit ungeschirmten Kabeln und/oder in offenen Messaufbauten verwendet, so ist vom Betreiber sicherzustellen, dass die Funk-Entstörbestimmungen unter Betriebsbedingungen an seiner Grundstücksgrenze eingehalten werden.

SOUND EMISSION

Note



This statement is provided to comply with the requirements of the German Sound Emission Directive, from 18 January 1991.

This product has a sound pressure emission (at the operator position) <70 dB.

- Sound Pressure L_p <70 dB (A).
- At Operator Position.
- Normal Operation.
- According to ISO 7779 (Type Test).

Model HP 8757D

Note



Herstellerbescheinigung

Diese Information steht im Zusammenhang mit den Anforderungen der Maschinenlärminformationsverordnung vom 18 Januar 1991.

- Schalldruckpegel L_p <70 dB(A).
- Am Arbeitsplatz.
- Normaler Betrieb.
- Nach DIN 45635 T. 19 (Typprüfung).

DECLARATION OF CONFORMITY

according to ISO/IEC Guide 22 and EN 45014

Manufacturer's Name: Hewlett-Packard Company
Manufacturer's Address: Network Measurements Division
1400 Fountaingrove Parkway
Santa Rosa, California 95403
U.S.A.

declares that the product

Product Name: Scalar Network Analyzer
Model Number: HP 8757D*
Product Options: All options

conforms to the following Product Specifications:

Safety: IEC 348
EMC: EN55011 Class A/CISPR-11 class A
EN50082-1-1991
IEC 801-2/1991 4kV CD, 8kV AD
IEC 801-3/1984 3V/m (26-500 MHz)
IEC 801-4/1988 500V

*The HP 8757D was qualified as part of product family, including the HP 8757C/E.

Santa Rosa

July 20, 1992

(Location)

(Date)

Dixon Browder, Quality Manager

Accessories and Supplies

Table 1-4, "Electrostatic Discharge" in Chapter 2, and Table 1-6 list available accessories and supplies. To order a listed item, provide the Hewlett-Packard part number and the quantity required; send the order to the nearest Hewlett-Packard sales and service office, listed at the back of this chapter.

Direct Mail Order System

Within the USA, Hewlett-Packard can supply parts through a direct mail order system. Mail order forms and specific ordering information are available through your local Hewlett-Packard sales and service office.

Advantages of using the mail order system are as follows:

- Direct ordering and shipment from the Hewlett-Packard parts center.
- No maximum or minimum order on any mail order (there is a minimum order quantity for parts ordered through a local HP office when the orders require billing and invoicing).
- Prepaid transportation (there is a small handling charge for each order).
- No invoices.

Direct Phone Order System

Within the USA, a phone order system is available for regular and hotline replacement parts service. A toll-free phone number is available, and Mastercard and Visa are accepted.

Regular Orders The toll-free phone number, (800) 227-8164, is available from 6 AM to 5 PM, Pacific time, Monday through Friday; a separate number, (415) 968-2347, is available after-hours, weekends, and holidays. Regular orders have a 4-day delivery time.

Hotline Orders Hotline service for ordering emergency parts is available 24 hours a day, 365 days a year. Hotline orders are normally delivered the following business day. There is an additional hotline charge to cover the cost of freight and special handling.

Table 1-4. Accessories and Supplies







Item	Description	HP Part Number
Documentation	Manual Set Operating Manual User's Guide Programming Guides: HP 9000 Series 200/300 HP Vectra Microsoft Quick Basic 4.5 HP Vectra Microsoft C 2.5 Quick Reference Guide Connector Care Service Manual	08757-90107 08757-90109 08757-90074 08757-90116 08757-90117 08757-90118 08757-90130 08510-90064 08757-90110
Cables HP-IB Power	1m (3 ft) Appropriate for your application	10833A See Table 1-6
Fuses	2.5 A 250 V NTD FE UL 1.5 A 250 V NTD FE UL	2110-0083 2110-0043
Touch-up Paint	Cobblestone Gray Dove Gray French Gray Parchment Gray	6010-1140 6010-1146 6010-1147 6010-1148
Cleaning Supplies Compressed air Isopropyl alcohol Foam swabs	30 ml squeeze bottle 99.5% pure 500	8500-5262 8500-5344 9300-1270
Rack Mount Kits	Mounting w/o Handles Mounting w/Handles	5062-3978 5062-4072
Labels	HP-IB Address	7120-6853
Packaging Material Outer Carton Inner Carton Side Rail Rear Spacers	23.79 INL x 13.5 INW Corrugated Folder 48.5 INL x 35 INW Foam Pad 26.5 INL x 13 INW Corrugated Pad 60.5 INL x 13 INW	9211-4499 08756-80009 08756-80010 08756-80011
Adapter¹	Type-N _(m) to 3.5 mm _(f)	08485-60005

¹ Part of Option 002.

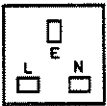
Table 1-5. Static-Safe Accessories

HP Part Number	Description
9300-0797	Set includes: 3M static control mat 0.6 m × 1.2 m (2 ft × 4 ft) and 4.6 cm (15 ft) ground wire. (The wrist-strap and wrist-strap cord are not included. They must be ordered separately.)
9300-0980	Wrist-strap cord 1.5 m (5 ft)
9300-1383	Wrist-strap, color black, stainless steel, without cord, has four adjustable links and a 7 mm post-type connection.
9300-1169	ESD heel-strap (reusable 6 to 12 months).

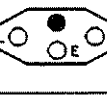
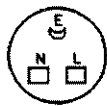
Table 1-6. Power Cables

PLUG TYPE ¹	CABLE HP PART NUMBER ²	PLUG DESCRIPTION ²	CABLE LENGTH (inches)	CABLE COLOR	FOR USE IN COUNTRY
250V 	8120-1351 8120-1703	Straight BS1363A 90°	90 90	Mint Gray Mint Gray	United Kingdom, Cyprus, Nigeria, Zimbabwe, Singapore
250V 	8120-1369 8120-0696	Straight ZNSS198/ASC112 90°	79 87	Gray Gray	Australia, New Zealand
250V 	8120-1689 8120-1692	Straight CEE7-VII 90°	79 79	Mint Gray Mint Gray	East and West Europe, Saudi Arabia, Egypt, Republic of So. Africa, India (unpolarized in many nations)
125V 	8120-1348 8120-1398 8120-1754 8120-1378 8120-1521 8120-1676	Straight NEMA5-15P 90° Straight NEMA5-15P Straight NEMA5-15P 90° Straight NEMA5-15P	80 80 36 80 80 36	Black Black Black Jade Gray Jade Gray Jade Gray	United States, Canada, Japan, (100V or 200V), Mexico, Philippines, Taiwan
250V 	8120-2104	Straight SEV1011.1959 24507, Type 12	79	Gray	Switzerland
250V 	8120-0698	Straight NEMA6-15P			United States, Canada
220V 	8120-1957 8120-2956	Straight DHCK 107 90°	79 79	Gray Gray	Denmark
250V 	8120-1860	Straight CEE22-VI (System Cabinet Use)			

1. E = Earth Ground; L = Line; N = Neutral.
2. Part number for plug is industry identifier for plug only. Number shown for cable is HP Part Number for complete cable including plug.

Table 1-7. Hewlett-Packard Sales and Service Offices

US FIELD OPERATIONS HEADQUARTERS	EUROPEAN OPERATIONS HEADQUARTERS	INTERCON OPERATIONS HEADQUARTERS
Hewlett-Packard Company 19320 Pruneridge Avenue Cupertino, CA 95014, USA (800) 752-0900	Hewlett-Packard S.A. 150, Route du Nant-d'Avril 1217 Meyrin 2/Geneva Switzerland (41 22) 780.8111	Hewlett-Packard Company 3495 Deer Creek Rd. Palo Alto, California 94304-1316 (415) 857-5027
California Hewlett-Packard Co. 1421 South Manhattan Ave. Fullerton, CA 92631 (714) 999-6700	France Hewlett-Packard France 1 Avenue Du Canada Zone D'Activite De Courtaboeuf F-91947 Les Ulis Cedex France (33 1) 69 82 60 60	Australia Hewlett-Packard Australia Ltd. 31-41 Joseph Street Blackburn, Victoria 3130 (61 3) 895-2895
Hewlett-Packard Co. 301 E. Evelyn Mountain View, CA 94041 (415) 694-2000	Germany Hewlett-Packard GmbH Berner Strasse 117 6000 Frankfurt 56 West Germany (49 69) 500006-0	Canada Hewlett-Packard (Canada) Ltd. 17500 South Service Road Trans-Canada Highway Kirkland, Quebec H9J 2X8 Canada (514) 697-4232
Colorado Hewlett-Packard Co. 24 Inverness Place, East Englewood, CO 80112 (303) 649-5000	Great Britain Hewlett-Packard Ltd. Eskdale Road, Winnersh Triangle Wokingham, Berkshire RG11 5DZ England (44 734) 696622	Japan Yokogawa-Hewlett-Packard Ltd. 1-27-15 Yabe, Sagamihara Kanagawa 229, Japan (81 427) 59-1311
Georgia Hewlett-Packard Co. 2000 South Park Place Atlanta, GA 30339 (404) 955-1500		China China Hewlett-Packard, Co. 38 Bei San Huan X1 Road Shuang Yu Shu Hai Dian District Beijing, China (86 1) 256-6888
Illinois Hewlett-Packard Co. 5201 Tollview Drive Rolling Meadows, IL 60008 (708) 255-9800		Singapore Hewlett-Packard Singapore Pte. Ltd. 1150 Depot Road Singapore 0410 (65) 273 7388
New Jersey Hewlett-Packard Co. 120 W. Century Road Paramus, NJ 07653 (201) 599-5000		Taiwan Hewlett-Packard Taiwan 8th Floor, H-P Building 337 Fu Hsing North Road Taipei, Taiwan (886 2) 712-0404
Texas Hewlett-Packard Co. 930 E. Campbell Rd. Richardson, TX 75081 (214) 231-6101		

Installation

This chapter provides information on the following topics:

- initial inspection
- instrument serial numbers
- environmental requirements
- electrostatic discharge hazards and precautions
- line voltage selector switch
- fuse inspection
- power cable inspection

Introduction

This section provides installation instructions for your HP 8757D scalar network analyzer. This section also includes information about initial inspection, damage claims, preparation for using the analyzer, packaging, storage and shipment.

Initial Inspection

The shipping container and packaging material are shown in Figure 2-11 (see chapter 1 “Accessories and Supplies” for part numbers). Inspect the shipping container for damage. If the shipping container or cushioning material is damaged, keep it until you have verified that the contents are complete and you have tested the analyzer mechanically and electrically.

If the shipment is incomplete or if the analyzer does not pass the operator’s check (see chapter 3) notify the nearest HP office. If the shipping container is damaged or the cushioning material shows signs of stress, notify the carrier. Keep the shipping materials for the carrier’s inspection. The HP office will arrange for repair or replacement without waiting for a claim settlement.

If the shipping container and cushioning material are in good condition, retain them for possible future use. You may wish to ship the analyzer to another location or to return it to Hewlett-Packard for service. Instructions for repackaging and shipping the instrument are located at the end of this chapter.

Shipment Contents

A complete shipment consists of two boxes (see chapter 1 for part numbers):

- One box contains one each of the following:
 - HP 8757D scalar network analyzer
 - HP-IB cable
 - power cable
 - type-N to 3.5 mm adapter (Option 002 only)
- The other box contains the analyzer documentation set:
 - operating manual
 - service manual

Serial Numbers

Hewlett-Packard makes frequent improvements to its products to enhance their performance, usability, or reliability, and to control costs. Hewlett-Packard service personnel have access to records of design changes to each type of equipment, based on the equipment's serial number. If you contact Hewlett-Packard about your analyzer, have the complete serial number available to make sure that you receive the most complete and accurate information possible.

A serial number label is attached to the rear panel of the analyzer. A typical serial number label is shown in Figure 2-1. The first four digits followed by a letter comprise the serial number prefix; the last five digits are the sequential suffix, unique to each instrument.

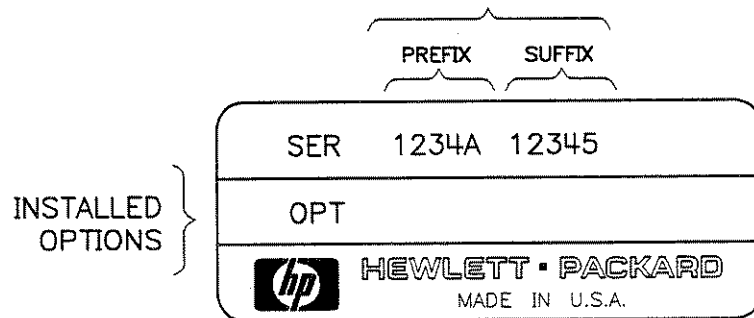

Figure 2-1. Typical Serial Number Label

Operating Environment

To meet the specifications listed in chapter 1, you must operate this instrument within the following limits:

- Temperature** 0 to +55°C (+32 to 131°F)
Altitude ≤ 4572 metres (15,000 feet)
Humidity 5 to 95% at +25 to +40° C (+77 to 104°F)

Protect the analyzer from temperature extremes which can cause internal condensation.

- Cooling** Leave 10 cm (4 in) of room at the rear of the cabinet and 7.6 cm (3 in) at the sides of the cabinet. In bench stacking, the plastic feet provide adequate clearance for the top and bottom surfaces. In rack mounting, filler strips provide the clearance.

The rear-mounted fan moves air into the instrument and out through the sides. Clean the fan regularly.

Electrostatic Discharge

Because electrostatic discharge (ESD) can damage or destroy electronic components, perform all work on assemblies consisting of electronic components at a static-safe work station.

Figure 2-2 is an example of a static-safe work station using two types of ESD protection that can be used either together or separately:

1. A conductive table mat and wrist-strap combination.
2. A conductive floor mat and heel-strap combination.

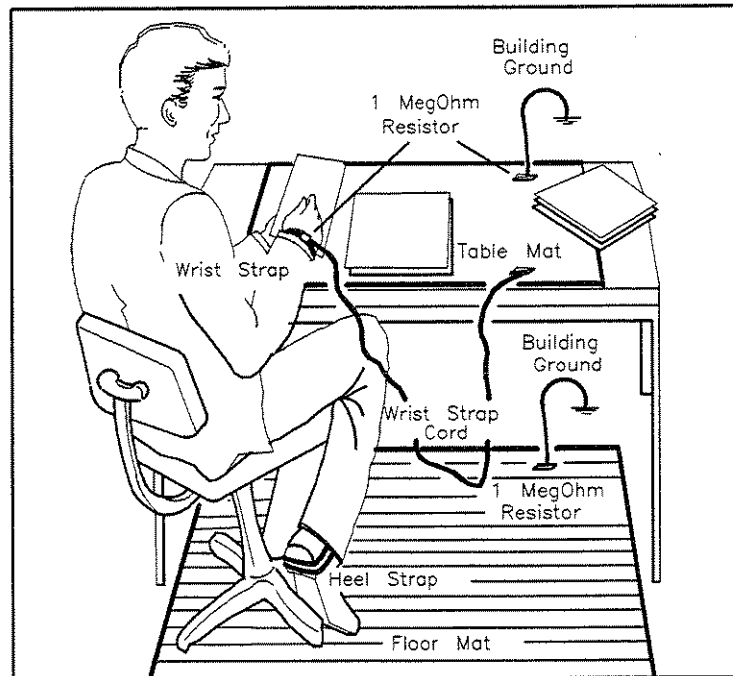

Figure 2-2. Example of a Static-Safe Work Station

Reducing Damage Caused by ESD

The following can help reduce ESD damage that occurs during testing and servicing operations:

- Before you connect a coaxial cable to an analyzer connector for the first time each day, momentarily ground the cable center and outer conductors.
- Ground yourself with a resistor-isolated wrist strap before touching the center pin of *any* connector, and before removing *any* assembly from the instrument.
- To prevent a buildup of static charge, ensure that all instruments are properly earth-grounded.

Static-Safe Accessories. See chapter 1 "Accessories and Supplies" for static-safe accessories available from Hewlett-Packard.

Power Requirements

Table 2-1. HP 8757D Power Requirements

Characteristic	Requirement
Input Voltage	100, 120, 220, or 240 V ($\pm 10\%$)
Frequency	48 to 66 Hz
Power	155 VA (max)

Cautions



Before you connect the instrument to the power source, check the rear-panel voltage selection card. An improper setting can damage the unit when it is turned on.

The available line voltage *must* be within $\pm 10\%$ of the line voltage selection shown in Table 2-2. If not, use an autotransformer between the power source and the instrument.

Checking the Line Voltage and Fuse

Both the voltage selection card and the fuse are located in the AC power module on the rear panel of the analyzer (see Figure 2-3). To select the line voltage and fuse (see chapter 1 for fuse part numbers):

1. Measure the AC line voltage.
2. Using the values in Table 2-2, follow the instructions in Figure 2-3.

Table 2-2. Line Voltage and Fuse Selection

Measured AC Line Voltage (V)	Voltage Selection Card Position	Fuse (A)
90 to 110	100	2.5
108 to 132	120	2.5
198 to 242	220	1.5
216 to 264	240	1.5

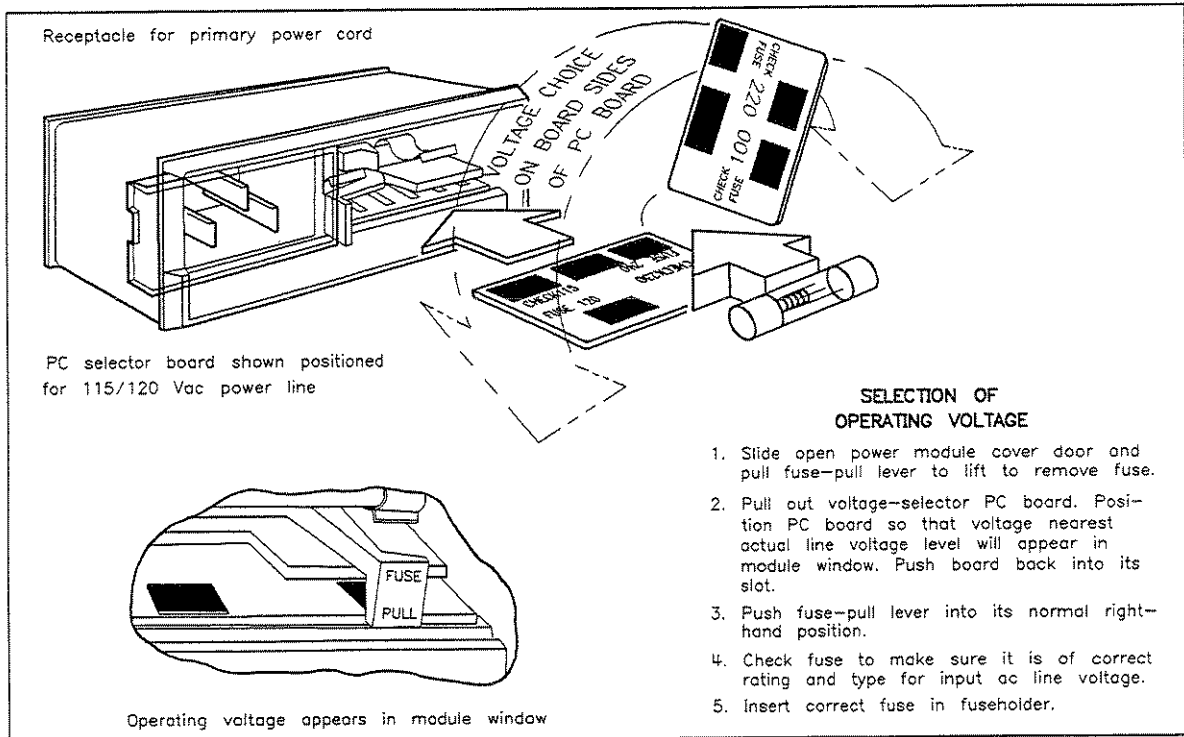

Figure 2-3. Setting the Voltage Selector Switch and Checking the Fuse

Checking the Power Cable

The analyzer is shipped with a three-wire power cable (appropriate for its original destination), in accordance with international safety standards. When connected to an appropriate power line outlet, this cable grounds the analyzer chassis. See chapter 1 for a list of available ac power cables, plug configurations, and the appropriate geographic area for each cable type.

Warning



Failure to properly ground the analyzer can cause personal injury or death. Before you turn the instrument on, connect its protective earth terminals to the protective conductor of the main power cable. Insert the main power cable plug only into a socket outlet that has a protective earth contact.

Do not use an extension cable, power cable, or auto transformer without a protective ground conductor. When using an auto transformer, be sure that its common terminal is connected to the protective earth contact of the power source outlet socket.

Equipment Required But Not Supplied

To make measurements with a standard analyzer, you must have a swept RF or microwave source and from one to three detectors or directional bridges (four with an Option 001).

AC Detection

AC detection measurements require square wave modulation capability at 27.778 kHz.

Firmware Compatibility

Table 2-3 lists the sweeper firmware revisions required for complete compatibility with the HP 8757D.

Table 2-3. Firmware Revisions

HP Sweeper	Firmware Revision
HP 8350B	≥ 6
HP 83522A	≥ 3
HP 83525A/B	≥ 3
HP 83540A/B	≥ 3
HP 83545A	≥ 3
HP 83550A	≥ 6
HP 83570A	≥ 3
HP 83572A/B	≥ 6
HP 83590A	≥ 6
HP 83592A/B/C	≥ 6
HP 83594A	≥ 6
HP 83595A	≥ 6
HP 83595C	All
HP 83596A	All
HP 83596B	All
HP 83597A	All
HP 83597B	All
HP 83598A	All
HP 83599A	All

Rack Mounting

Caution



Use only the specified screws to install the rack mount kit. Longer screws can damage internal components located behind the screw mounting holes.

Rack Mounting without Front Handles (Option 908)

Option 908 instruments are shipped with a rack mount kit. The kit supplies the hardware and installation instructions to prepare the instrument to mount on an equipment rack with 482.6 mm (19 in) support spacing. To order additional rack mount kits, see chapter 1.

1. Refer to Figure 2-4.
2. Remove each front handle trim ①:
 - a. Insert the tip of a screwdriver between the back edge of trim and the front handle.
 - b. Pull forward.
3. Remove four screws ④ and one front handle assembly ③ per side.
4. Attach one rack mount flange ② with four panhead screws ④ per side.
5. Remove the feet and tilt stands ⑤.
6. Save the flat head screws and front handle assemblies for reuse.

Rack Mounting with Front Handles (Option 913)

Option 913 instruments are shipped with a rack mount kit. The kit supplies the hardware and installation instructions to prepare a standard instrument (with handles) to mount on an equipment rack with 482.6 mm (19 in) support spacing. To order additional rack mount kits, see chapter 1.

1. Refer to Figure 2-4.
2. Remove each front handle trim ①:
 - a. Insert the tip of a screwdriver between the back edge of trim and the front handle.
 - b. Pull forward.
3. Remove four screws ④ and one front handle assembly ③ per side.
4. Attach one rack mount flange ② and one front handle assembly ③ with four panhead screws ④ per side.
5. Remove the feet and tilt stands ⑤.
6. Save the flat head screws and front handle assemblies for reuse.

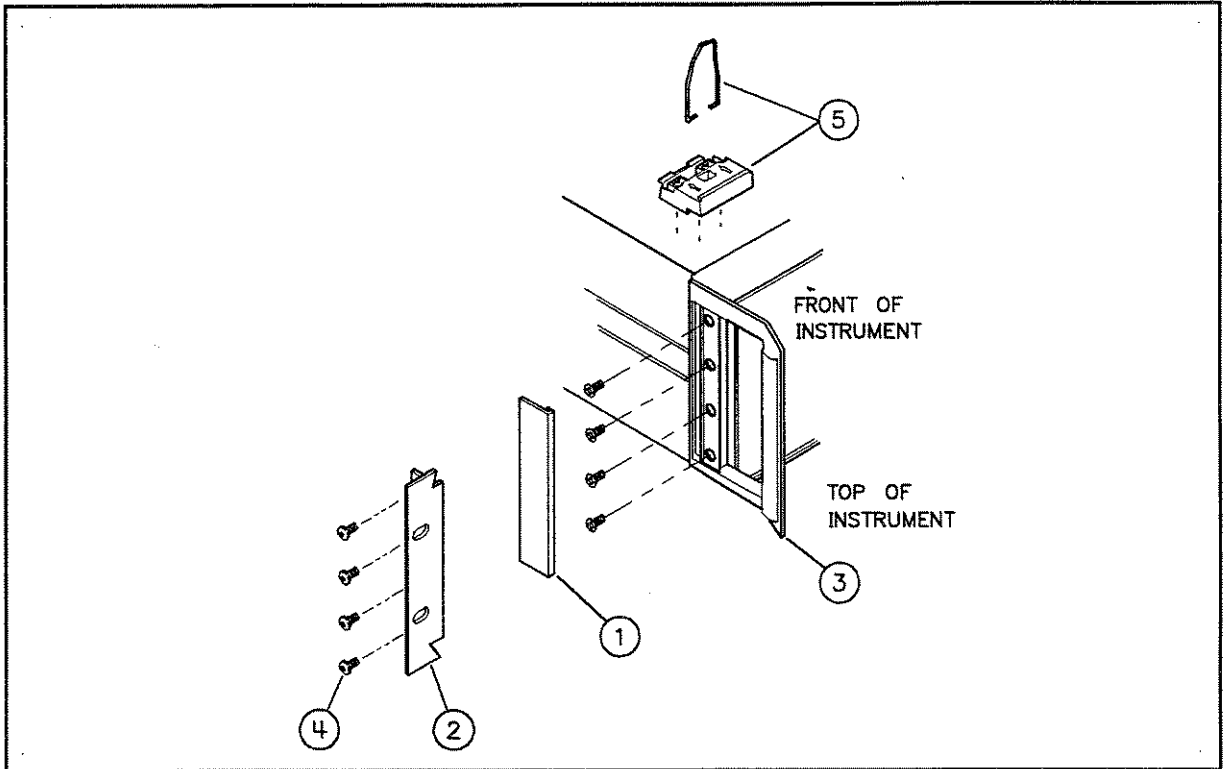

Figure 2-4. Rack Mounting the Analyzer

Connecting the Analyzer to a Source

Figure 2-5, Figure 2-6, Figure 2-7, and Figure 2-8 show the interconnections between the analyzer and three commonly used sources.

External Modulation

Unlike the HP 8350, 8360, and 83750 Series sources, HP 8340 and 8341 Series synthesizers do not provide an internal 27.778 kHz modulated signal (used in AC measurements). Use the analyzer's 27.778 kHz modulation signal to externally modulate the source, connected as described in Table 2-4.

Table 2-4. External Modulation Connections

HP Source	Serial Prefix	Connection/Function (W/O System Interface Connected)	Connection/Function (With System Interface Connected)
HP 8340A	< 2302A	Pulse Input/Pulse	Input/Pulse
	≥ 2320A	AM Input/Shift Pulse	AM Input ¹
HP 8341A	all	AM Input/Shift Pulse	AM Input ¹
HP 8340B	all	Pulse Input/Pulse	Input/Pulse ¹
HP 8341B	all	Pulse Input/Pulse	Pulse Input/Pulse ¹

¹ The correct function is programmed automatically.

Other Configurations

If you operate the analyzer without connecting the HP 8757 system interface, make the connections to the analyzer's POZ BLANK and SWEEP IN 0-10V only. Also use this configuration with the HP 8620 Series sweep oscillator and with non-HP sources. For modulation, connect the MODULATOR DRIVE to the source PULSE input, or use an external modulator (such as an HP 11665B).

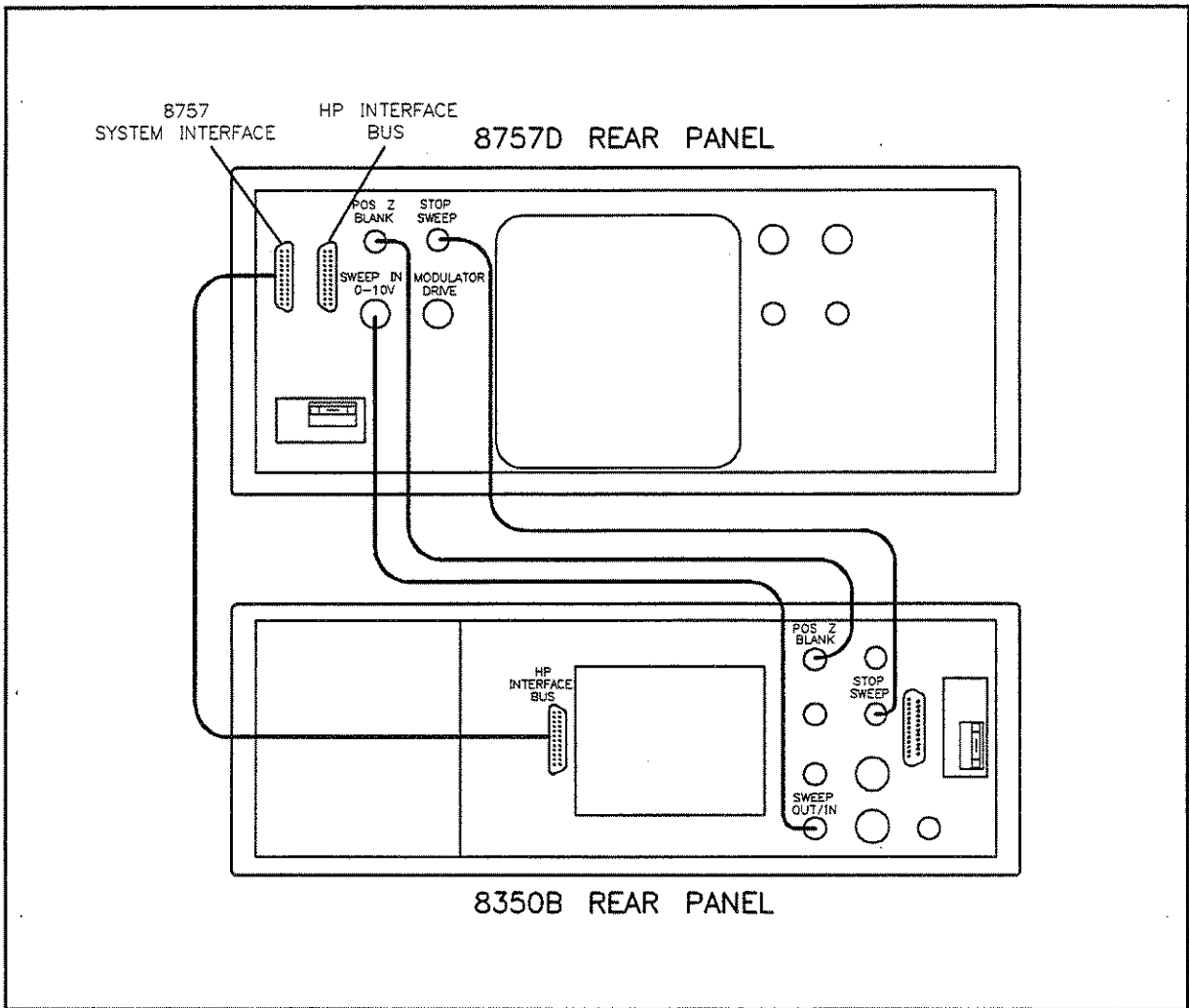

Figure 2-5. Analyzer to HP 8350 Sweep Oscillator Interconnections

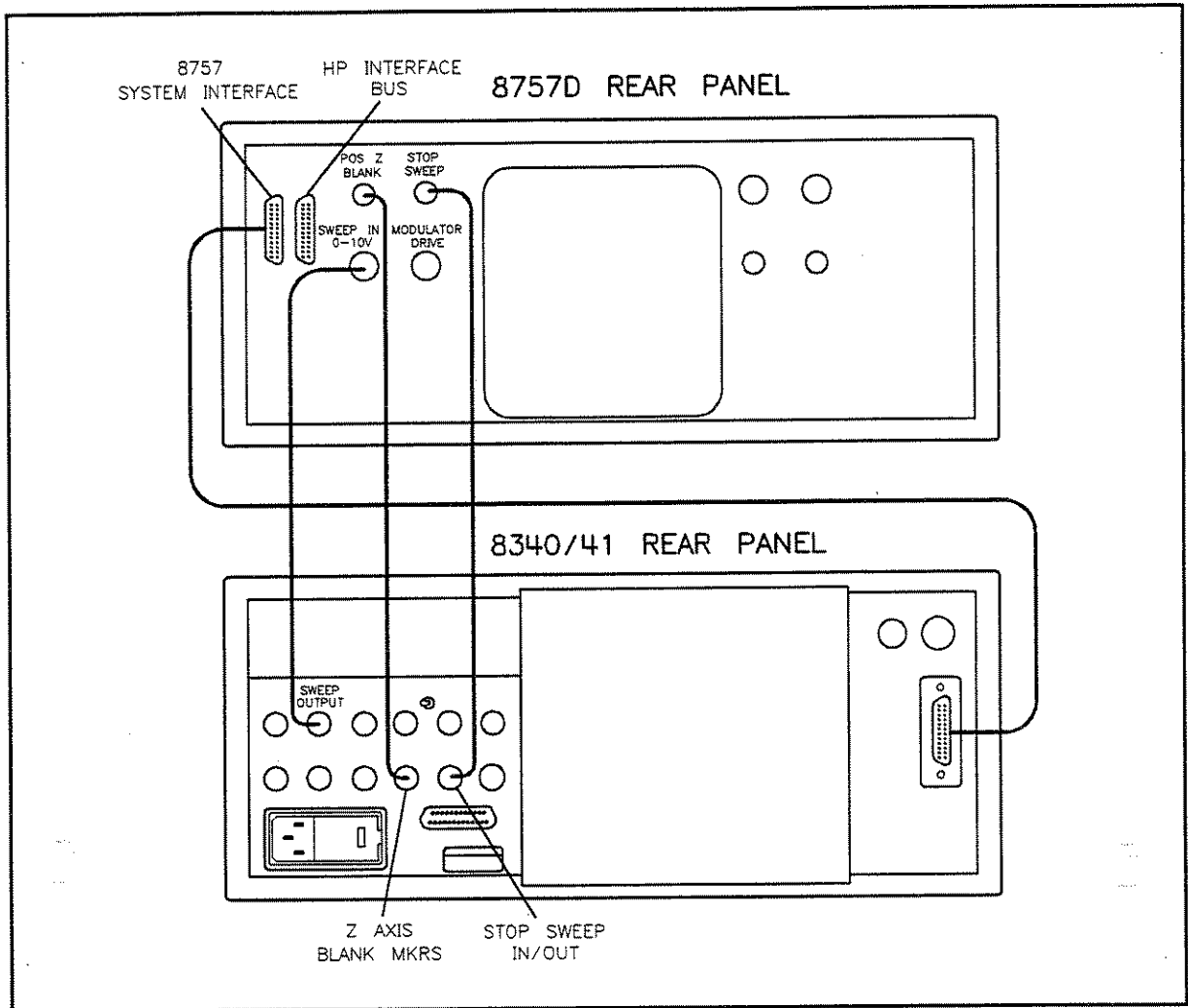

Figure 2-6. Analyzer to HP 8340 and 8341 Series Synthesizer Interconnections

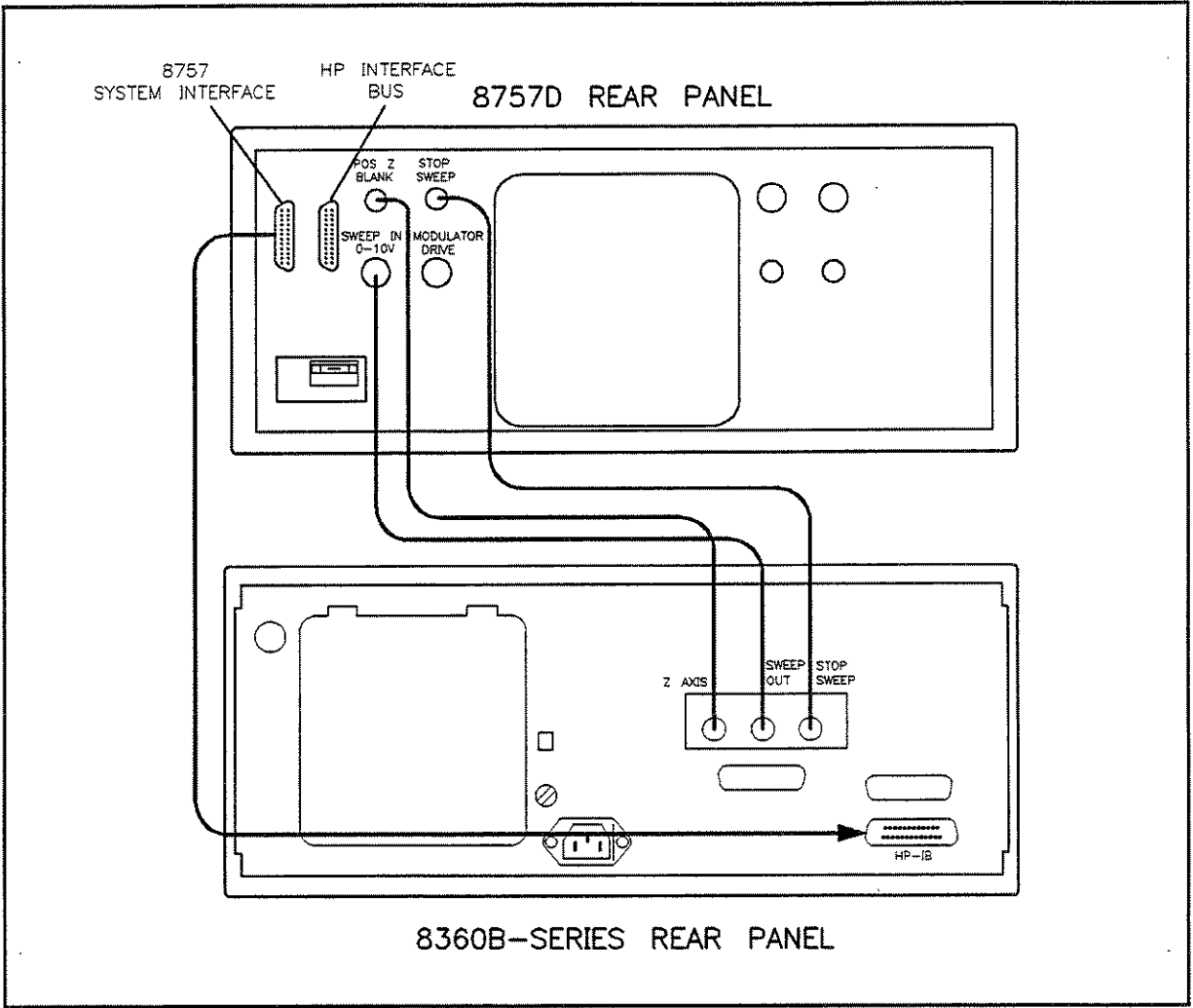

Figure 2-7. Analyzer to HP 8360 Series Synthesizer Interconnections

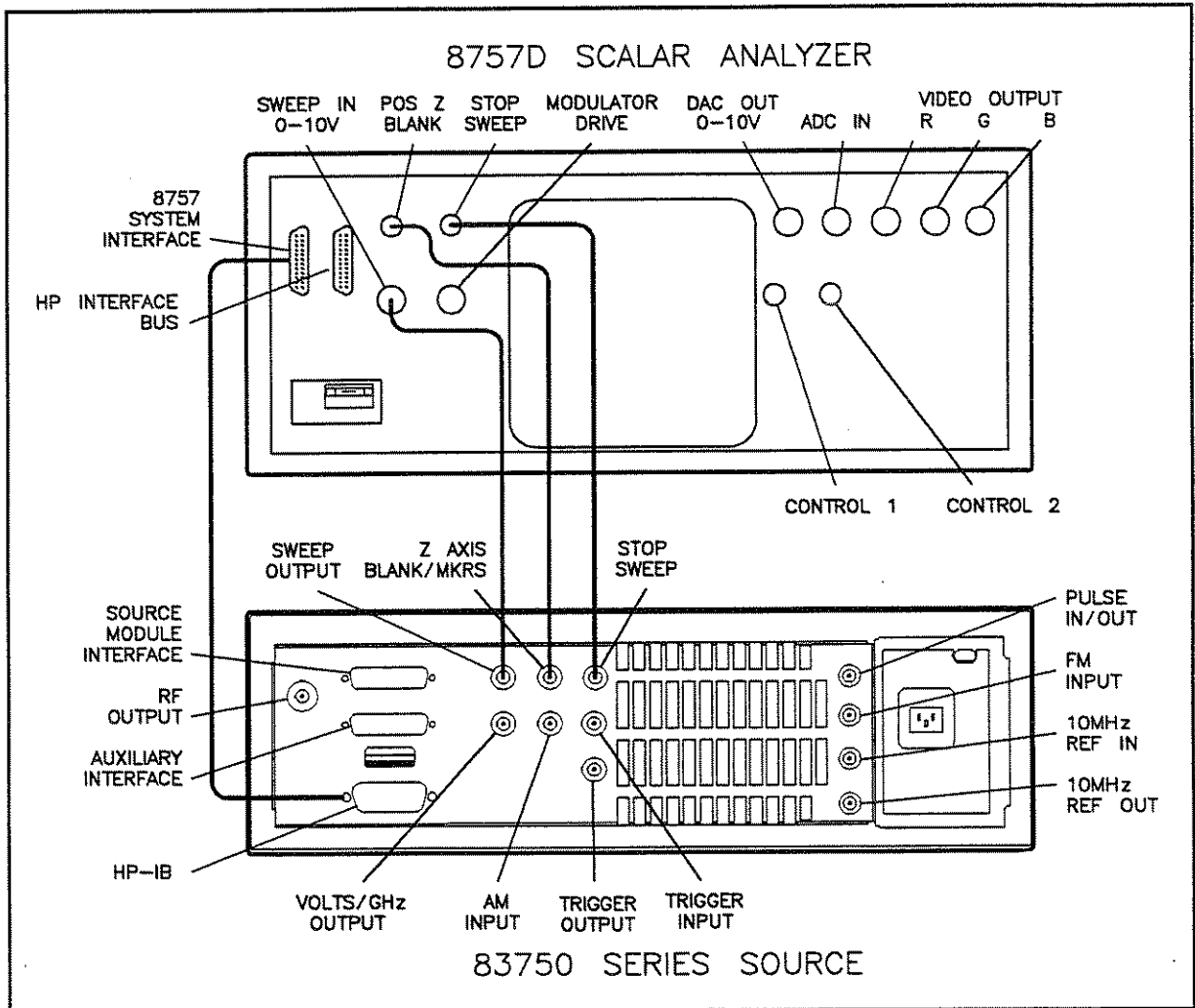

Figure 2-8. Analyzer to HP 83750 Series Synthesizer Interconnections

Connecting the Analyzer to an External Monitor

Use the three rear panel outputs (RGB) to drive an external monitor (see chapter 1 for specific video output characteristics). Connect the three BNC analyzer outputs (RGB) to the corresponding monitor inputs.

If you use a monochrome monitor, operate the analyzer in monochrome mode and connect only the green (G) output to the monitor.

Setting the HP-IB Address

In remote mode, a controller communicates through the HP-IB, identifying each instrument on the bus by its HP-IB address. Because of this, each instrument on an HP-IB *must* have a unique address (0 through 29 are available).

Factory Setting

The factory sets the analyzer to address 16. The central processing unit (CPU) reads this address from the firmware when the instrument is first turned on and stores it in memory. The address changes only when the value in memory changes, either through a front panel entry, or when you change the firmware. With a firmware change, the address again defaults to 16.

Checking the Address

To display the current HP-IB address on the CRT:

1. Press **LOCAL**.
2. Select **8757**.

Changing the Address

To change the HP-IB address:

1. Press **LOCAL**.
2. Select **8757**.
The CRT displays the current address.
3. Using the front panel keypad, enter the new address.
4. Press **ENT** to terminate the entry.

The CRT displays the new address. Turning the line switch off or presetting the instrument does not affect this address.

Recording the Address

Figure 2-9 shows an HP-IB label (see chapter 1 for ordering information), available for recording instrument HP-IB addresses.

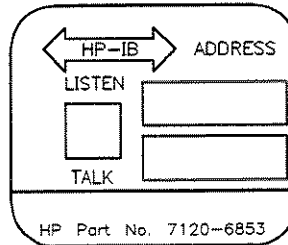

Figure 2-9. HP-IB Address Label

HP-IB Connectors and Cables

A tutorial description of HP-IB is available from Hewlett-Packard (see chapter 1 for ordering information). See also "Remote Operation," which describes the analyzer's HP-IB capabilities. Figure 2-10 illustrates an HP-IB connector pin configuration and signals.

Connectors

The analyzer has two rear panel HP-IB connectors:

1. The 8757 System Interface (J1).

This remote programming interface lets you connect the analyzer to the HP-IB connector of compatible instruments and use the analyzer (in either local or remote operation) to control a plotter, printer, or source. This dedicated HP-IB port is used exclusively by the analyzer; do not connect a controller to this connector.

2. The HP Interface Bus (J2).

This remote programming interface lets you connect the analyzer to a controller via HP-IB with or without additional instruments. You can then remotely operate the analyzer with the same control (except for power, line switch, and internal tests) as with local operation. The controller maintains remote control by sending commands to and receiving data from the analyzer over the HP-IB.

Cables

Connect instruments on the HP-IB or on the system interface using HP-IB cables. The cables are available in lengths from 0.5m (1.6 ft) to 4m (13.2 ft). See chapter 1 "Accessories and Supplies" for ordering information.

You may connect up to fifteen instruments in parallel on the HP-IB or the system interface, but if the system cable is too long or if the accumulated cable length between instruments is too long, the system cannot maintain the proper data and control lines voltage levels and timing relationships (see Table 2-5).

Table 2-5. HP-IB Cabling Restrictions

Number of Instruments in the System ¹	Maximum Cable Length (m/ft)
2	4/12
> 2	2/6 ²
na	20/65 ³

1 Including the analyzer.

2 To each instrument.

3 Between all units.

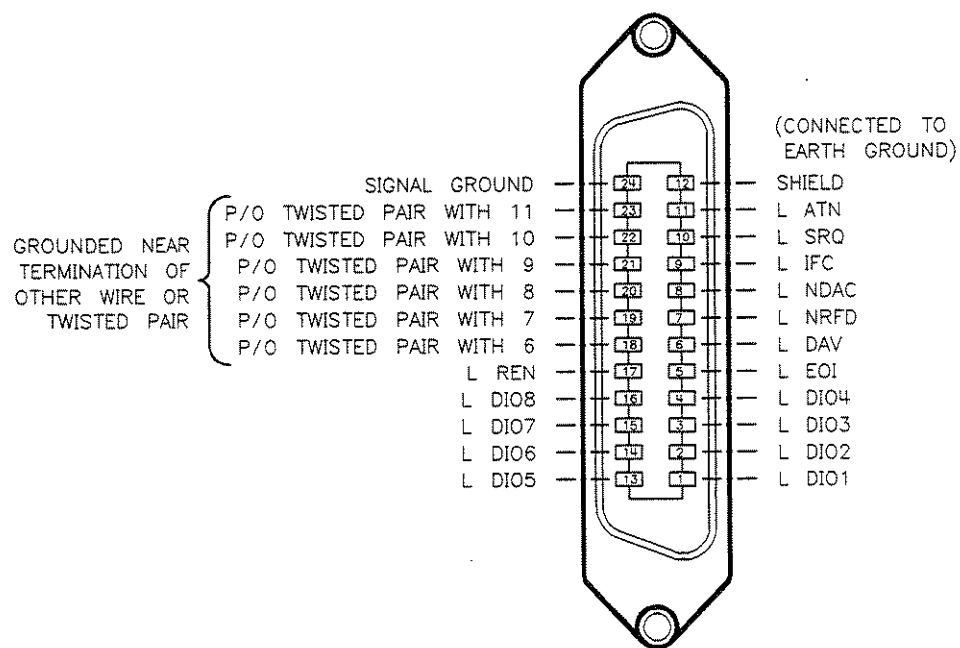

Figure 2-10. HP-IB Connectors: Signals and Pin Configuration

Storing and Shipping

Environment

Store or ship the instrument in environments within the following limits:

Temperature	-40 to + 70°C (-40 to + 167°F)
Altitude	≤ 15,240 metres (50,000 feet)
Humidity	90% at +65° C (+149°F)

Protect the instrument from temperature extremes, which can cause internal condensation.

Packing the Instrument

Hardware

- If the analyzer has handles, but no rack mounting hardware, go to “Packaging.”
- If the instrument has neither rack mount flanges, nor handles, attach the handles, and go to “Packaging.”
- If the instrument has handles *and* rack mount flanges, remove the flanges, reattach the handles, and go to “Packaging.”
- If the instrument has rack mount flanges, but no handles, remove the flanges, attach the handles, and go to “Packaging.”

Packaging

Containers and materials identical to those used in factory packaging Figure 2-11 are available through Hewlett-Packard offices (see chapter 1 for ordering information). If you choose to package the instrument with commercially available materials, follow these instructions.

1. Wrap the instrument in heavy paper.
2. Use a strong shipping container. A double-wall carton made of 350-pound test material is adequate.
3. Use enough shock-absorbing material (3 to 4 inch layer) around all sides of the instrument to provide a firm cushion and prevent movement inside the container. Protect the control panel with cardboard.
4. Seal the shipping container securely.
5. Mark the shipping container “FRAGILE”.

Returning an Instrument for Service

If your analyzer requires service, contact the HP office nearest you for information on where to send it. See the list of sales and service offices at the end of this manual). When you send the analyzer to Hewlett-Packard, include a service tag (located at the end of this chapter), on which you provide the following information:

1. Your company name and address (do not give a post office box).
2. A technical contact person within your company, and their complete phone number.
3. The complete model and serial number of the instrument.
4. Indicate the type of service required (calibration or repair).
5. Include any applicable information.

When making inquiries, either by correspondence or by telephone, please refer to the instrument by model number and full serial number.

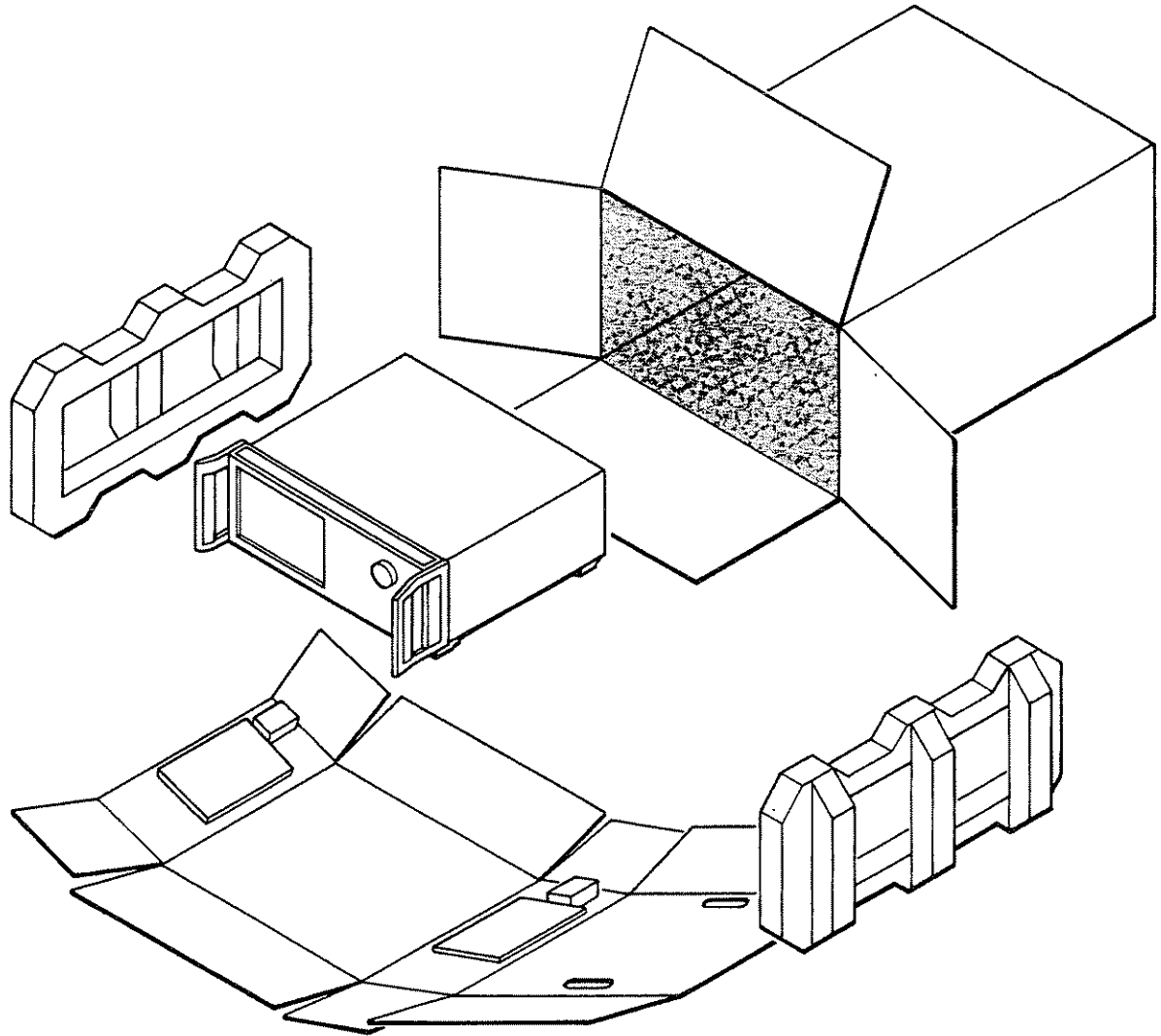

Figure 2-11. Packaging for Shipment Using Factory Packaging Material

Operation

This operating section provides information that is divided into the following topics and sections:

- firmware revision history

Local Operation

- *User's Guide*, which contains:
 - typical measurement setups
 - example transmission and reflection measurements
- *Operating Reference*, which contains:
 - front and rear panel operating features
 - front panel key functions
 - softkey functions
 - operator's check

Remote Operation

This section contains:

- information on converting HP 8757A software
- quick reference guide
- programming guides for example programs and programming codes

In Case of Difficulty

This section contains information on what to do if you encounter a problem with the analyzer. It provides suggestions for minor problems that do not involve defects in the internal circuitry. (The service manual, chapter 8, provides in-depth troubleshooting information.)

HP 8757D Firmware Revision History

Revision 5.1

Initial shipment release.

User's Guide

HP 8757D
Scalar Network Analyzers

I N T R O D U C T I O N

This document is intended to provide an introduction to the operation of the HP 8757D scalar network analyzer. It is organized in a manner that will familiarize the user with many of the capabilities and features of the HP 8757D, illustrating actual operating sequences for various measurements.

Chapter 1 provides a basic introduction to the HP 8757D's front panel, then leads the user through the general measurement procedure for making scalar network measurements.

Chapters 2 and 3 describe the procedure for making transmission and reflection measurements. The examples have been selected to illustrate many of the operating modes of the HP 8757D, and the simplicity of their design. The bandpass filter (HP Part No. 0955-0446) utilized as the device under test in many of the examples, demonstrates the techniques for measuring common devices.

Chapters 4 and 5 describe advanced features, such as limit testing for device evaluation and the alternate sweep capabilities of the HP 8350B, HP 8340B/8341B, and HP 8360 series sources.

Chapter 6 illustrates the HP 8757D's external disk save/recall capabilities, while chapter seven covers special functions such as color selection and frequency blanking. This document also includes an appendix, that describes the capabilities and advantages of the AC and DC detection modes.

The HP 8757D *Operating Manual* has more complete operating information. Use this reference for further information on any topic covered in this User's Guide.

How to use this guide

To gain the most benefit from this User's Guide, it is recommended that you proceed sequentially through the guide, starting with chapter 1 and ending with chapter 7. Each chapter builds upon the information presented in previous chapters. Also, the examples provided within each chapter are written in procedural form. To follow the examples, start at the beginning of each chapter.

To simplify the execution of the measurements presented, the HP 8757D's front panel "hardkeys" are differentiated from the display "softkeys." The hardkeys are presented in bold capital letters (e.g. [CAL]) and the softkeys are *bold italic* capital letters (e.g. [SHORT/OPEN]). Equipment utilized in this guide

HP 8350B Sweeper with HP83592B RF Plug-in.

Bandpass Filter - HP Part No. 0955-0446.

HP 8447D Amplifier.

HP 85027E Directional Bridge.

Includes 3.5 mm (f) to (f) adapter
HP Part No. 85027-60005.

and 3.5 mm (f) open/short
HP Part No. 85027-60004.

HP 11664A Detector.

HP 11664E Detector.

HP 11667A Power Splitter.

HP 8491A 6 dB Attenuator.

HP 8491B 10 dB Attenuator.

HP Part No. 1250-1743.

Type N (m) to 3.5 mm (m) adapter

HP Part No. 1250-1744.

Type-N (m) to 3.5 mm (f) adapter

HP 85022 Cable Kit.

Chapter 1	3	Chapter 6	23
Operating the HP 8757D		External disk save/recall	
Front Panel Tour		Setting Up the Disk Drive	
General Measurement Setup		Intializing a Blank Disk	
Preset		Save/Recall Functions	
Setup Test Connections			
Set System Control Settings		Chapter 7	25
Perform Calibration		Special functions	
Save Instrument State		Color Selection	
Measure Device Under Test		Frequency Blanking	
Output Results			
Chapter 2	10	Appendix	26
Transmission measurements with the HP 8757D		AC versus DC detection	
Basic System Configuration			
Measurement Setup for Insertion Loss and Gain		Index	27
Insertion Loss			
3 dB Bandwidth			
Peak-to-Peak Ripple			
Out of Band Rejection			
Adaptive Normalization			
Measuring Active Devices			
Gain Compression			
Chapter 3	17		
Reflection measurements with the HP 8757D			
Signal Separation			
Device Termination			
Measurement Accuracy			
Measurement Setup for Return Loss and SWR			
Return Loss			
SWR			
Chapter 4	19		
Limit lines			
Accessing the Limit Line Menu			
Creating Limit Lines			
Editing Limit Lines			
Creating Limit Lines for a Bandpass Filter			
Chapter 5	21		
Alternate sweep			

Operating the HP 8757D

Front panel tour

The front panel of the HP 8757D was designed to simplify measurement operations. Each "hardkey" accesses a CRT-displayed menu. These menus offer a list of possible selections for the completion of a particular operation. Each selection corresponds to one of the eight "softkeys" located to the right of the display. Using front panel keys to access softkey menus allows for the expansion of the analyzer's capabilities, without adding front panel complexity.

CRT display

With the selection of each hardkey or softkey, the HP 8757D's display is updated to exhibit the current measurement configuration and status information. For those parameters not continually shown on the display, select the appropriate key to exhibit the parameter in the active entry area.

The HP 8757D offers a color display that may be customized to the user's particular color preferences. A monochrome display mode is also available at the touch of a softkey in the [DISPLAY] menu.

Mode labels

This area of the CRT is used to show the current status of various functions for the activated channels (an example is shown below). The following table lists the status symbol notations and their meanings.

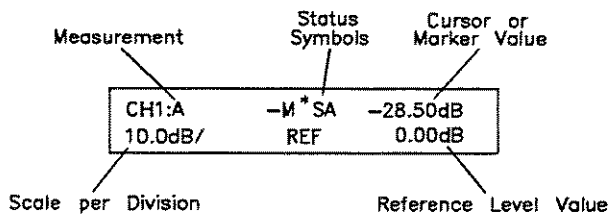

Notation	Definitions
-M	The trace displayed represents the subtraction of the stored data from measured data.
MEM	The trace displayed represents stored data.
S	Trace smoothing is on.
A	Trace averaging is on.
*	Adaptive Normalization is on.
U	Adaptive Normalization is on, but uncalibrated (the frequency span has been increased beyond the original calibration span).

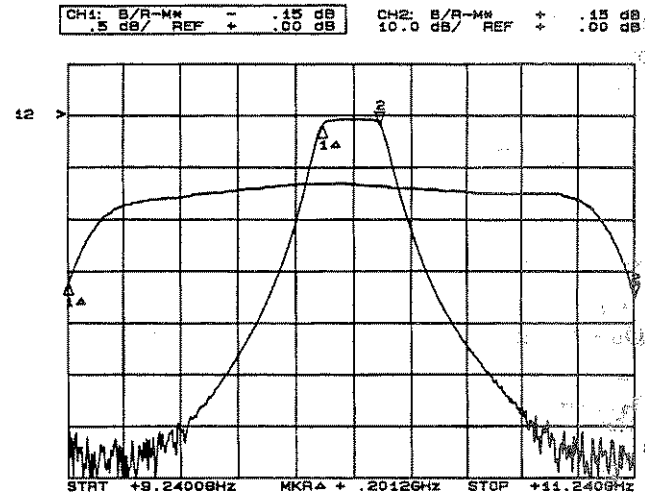

Channel selection

Many measurement and display functions are independently selectable for each channel. To modify the parameters of a particular trace, first select that channel (making it the active channel), then make the desired measurement choices. The mode label area of the active channel is boxed to differentiate it from other enabled channels.

The HP 8757D may display as many as four channels at one time. A channel may be switched off by pressing the channel hardkey to make it the active channel, then pressing the hard key a second time to turn it off.

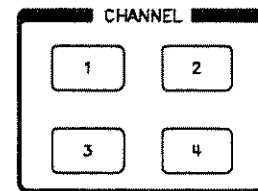

Function selection

There are eight function keys, which allow the user to select the measurement parameters, calibrate the measurement setup, and manipulate data presentation. [MEAS], [DISPLAY], and [CAL] access menus which provide the user with a choice of measurement and display configurations, and calibration sequences. The [SCALE], [REF], [CURSOR], [AVG], and [SPCL] keys allow the user to manipulate information in a manner that enhances usability of the measured data.

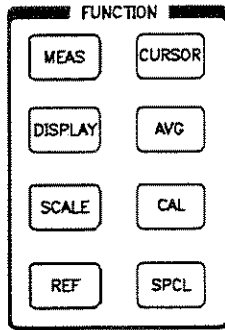

Data entry

The ten digit keypad is used to enter numeric values for a chosen parameter. Once the numbers have been selected, they need to be terminated with the appropriate units located on the right side of the keypad. Use [ENT] to terminate data that is unitless. In addition to entering data with the keypad, the knob may be used to make continuous adjustments, while the [▲] and [▼] keys allow the values to be changed in steps.

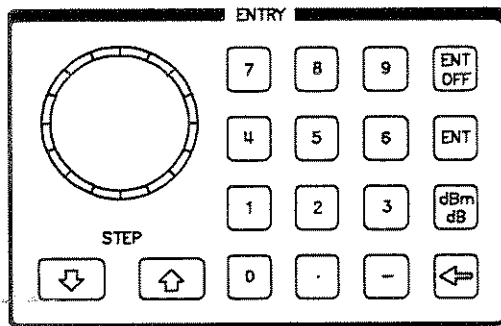

Instrument state selection

The Instrument State keys control system functions that apply to the entire instrument, they are not channel specific. [SYSTEM], [SAVE], [RECALL], [PRESET], and [LOCAL]; implement such functions as: HP-IB plotter, printer, and disk controls, built-in diagnostic tests, front panel save/recall, instrument preset, and HP-IB instrument addresses.

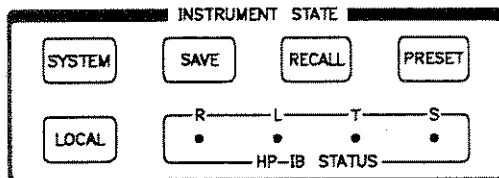

General measurement sequence

Even with its wide range of capabilities, the HP 8757D is easy to operate. Common measurements can be set up with only a few front panel selections. This section describes a general approach to performing network measurements with the HP 8757D.

The following sequence is used throughout this User's Guide to illustrate the use of the HP 8757D in its various operating modes. The individual steps are discussed in detail in the sections that follow.

Preset

Return to a known state.

Connections

Set up the test configuration for your particular device under test.

Controls

Set up the instrument with the following steps:

1. Select measurement input.
2. Set up source parameters.

Calibrate

Characterize the systematic errors and remove their effect from the displayed data.

Save

Save the instrument configuration and calibration to facilitate recalling measurement states.

Measurement

Measure the performance of the device under test. Utilize the cursor functions to extract key measurement information.

Output Results

Create a permanent record of your measurement data, by outputting the test results to a plotter or printer. Also, obtain virtually unlimited storage of test setups and measurement data with the HP 8757D and an external disk drive.

Step one: preset

Selecting [PRESET] activates a self test routine; when completed, the analyzer returns to a pre-determined state. [PRESET] also initializes all instruments attached to the 8757 System Interface. The major default conditions are listed in the table below.

Primary default conditions

Analyzer	
Channel	Channel 1 On, Active Channel 2 On Channel 3 Off Channel 4 Off*
Measurement	A on Channel 1 B on Channel 2 C (Option 001) or B on Channel 3 R on Channel 4
Display format	Displays the current measurement data
Colors	Unchanged
Scale	20 dB/division
Reference	Reference Level equals 0 dBm Reference Position unchanged from previous setting
Number of points	401 trace points
Detection mode	AC
Trace memories	Unchanged
Save/Recall memories	Unchanged
Detector amplitude offsets	Set to 0
Detector frequency offset ¹	Off, start and stop values set to 50 MHz
HP-IB addresses	Unchanged
Cursor	Off Search Value equals -3 dBm
Modulation drive	On
Averaging	Off
Smoothing	Off
Adaptive normalization	Off
Limit lines	Unchanged
Source	
Frequency	Full span of source
Sweep time	200 ms
Modulation	On
Plotter	
Abort all activity	
Printer	
Abort all activity	
Disk	
Abort all activity	

1. Function only available when using the HP 85037 series precision detectors.

Step two: set up test connections

The device under test (DUT) determines the actual system configuration; the three (optionally four) inputs offer the user a variety of possibilities. Simple insertion loss or gain measurements may be made with only a power splitter and detector. Reflection measurements require a directional bridge or coupler.

The following figure presents a block diagram of a basic scalar coaxial system, configured for ratio reflection and transmission measurements. Adapters, attenuators, isolators, or other components may also be required depending on the actual DUT and the measurement parameters being characterized. Connector savers (high quality adapters) should be utilized whenever possible to preserve test ports of higher cost components (i.e. directional bridges), thus minimizing damage from repeated connect/disconnect cycles.

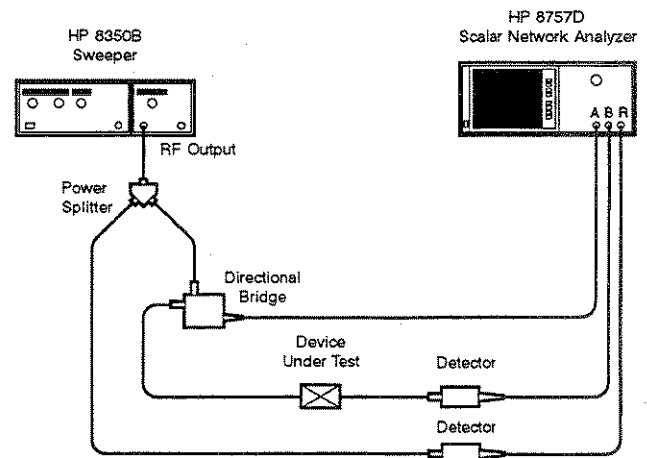

Step three: set system control settings

1. Select measurement input.
2. Set up source parameters.

Following preset, channel one is active and channel two is on. Use the [MEAS] key to select the appropriate single or ratioed measurement input for characterizing the desired parameters.

Use the controls of the source to set the start and stop frequencies that correspond to the frequency range of the device under test. The 8757 System Interface bus allows the HP 8757D to act as system controller, monitoring source functions. This interface provides frequency annotation on the CRT display, full use of all source marker modes, and control of the analyzer and source preset and save/recall functions. Also, it facilitates full use of the source sweep functions, such as CW (continuous wave), alternate and power sweep modes.

If the DUT is sensitive to the input power level, the power should be measured at the test port of the power splitter or directional bridge. To accomplish this, the device should be removed and the detector attached directly to the test port, then the power level on the source should be adjusted until the desired RF power level appears on the analyzer display. Typically, when the system is connected as in the previous figure, there is a 12 to 14 dB loss in power (from the power splitter and directional bridge) between the output of the source and the output of the test port. Once the power level has been set, reconnect the DUT.

Step four: perform calibration

Accuracy in network analysis is greatly influenced by factors external to the network analyzer. Parts of the measurement system such as cables, adapters, detectors, and directional bridges all introduce variations that can distort the actual performance of the DUT. For this reason, it is important to start with high quality components in your measurement system as well as ensuring these components are properly cared for. Application Note 326, *Principles of microwave connector care for coaxial system* (HP part no. 5954-1566), provides some valuable care and connection techniques which will help ensure optimum accuracy is obtained from your scalar network analyzer.

In the case of an absolute power calibration, the calibration is not dependant upon the instrument state. Source frequency and power and analyzer measurement settings may be changed without impacting the calibration. For transmission and reflection measurement calibrations, these calibrations are dependant upon the measurement configuration. Only when the adaptive normalization function is activated may the source frequency be changed without invalidating the calibration. Power may be changed if the system is configured for ratio measurements. When new parameters are required, the previous calibration becomes invalid and recalibration must occur.

Absolute power calibration (HP 8757D option 002 only)

The internal power calibrator in the HP 8757D option 002 is a 50 MHz power transfer standard used to precisely characterize the selected detector's performance from +20 to -50 dBm. While designed specifically for use with the HP 85037 series precision detectors, the power calibrator may also be used with HP's other detectors and directional bridges to obtain optimum absolute power accuracy and dynamic accuracy performance.

NOTE: The absolute power calibration must be performed before a transmission or reflection calibration.

Calibration sequence

[CAL]	[MORE]	Accesses calibration menu.
	[POWER CAL]	Select power calibration.
	[DET B]	Select detector B for calibration. Connect detector B to PWR CAL output. When calibrating a directional bridge, connect the bridge's RF input to the PWR CAL output and connect a short to the test port.
	[START CAL]	Executes the power calibration.

The power calibration results will be retained by the HP 8757D option 002 as long as the detector remains attached to the analyzer's input. Once disconnected, the calibration will be lost and a re-calibration required.

Transmission measurement calibration

For a transmission measurement, a "thru" is the calibration standard. It is accomplished by removing the DUT and directly connecting the measurement test port to the detector, thus establishing a 0 dB loss (or gain) reference.

Calibration sequence:

[CAL]	Accesses calibration menu.
[THRU]	Sets up calibration; remove DUT, connect thru.
[STORE THRU]	Stores calibration in memory of active channel.
[DISPLAY]	Accesses display menu.
[MEAS-MEM]	Normalizes measurement trace; subtracts data stored in memory (calibration data) from current measurement data.

Reflection measurement calibration

Coaxial scalar systems commonly use a short and open as the calibration standards for a reflection measurement. Since either standard reflects all incident power, they provide a convenient 0 dB reference. Mismatches and directivity in the test setup cause calibration and measurement errors that vary as a function of frequency. A test setup with either a short circuit or a shielded open include the same calibration errors 180° out of phase with each other. Therefore, by averaging the responses of a short circuit and a shielded open circuit the mismatch and directivity effects will cancel during calibration, producing an accurate reflection reference. With waveguide scalar measurement systems only a fixed short may be utilized as the calibration standard, since it is impossible to create a full reflection open circuit.

Calibration sequence:

[CAL]	Accesses calibration menu.
[SHORT/OPEN]	Sets up calibration; connect short.
[STORE SHORT]	Connect open.
[STORE OPEN]	Stores calibration in memory of active channel.
[DISPLAY]	Accesses display menu.
[MEAS-MEM]	Normalizes measurement trace.

Step five: save instrument state

Utilize the HP 8757D's internal memory or an external disk drive to save/recall the instrument configuration and calibration. This step will save time and effort when reconfiguring frequently used measurement setups or recalling a configuration that was lost after inadvertently pressing [PRESET] or cycling the line power.

Internal storage

The [SAVE] and [RECALL] keys are used to store and retrieve up to nine complete front panel states of the analyzer and the source (if the 8757 System Interface is connected). Color selections on the HP 8757D may not be saved internally, but may be stored on a disk. Only registers 1 through 4 may store the calibration memory, limit lines, and titles from channels 1 and 2 along with the instrument states. Information may be stored or retrieved internally by selecting [SAVE] or [RECALL], then the number of the storage register. The instrument states are saved in a non-volatile memory, and will not be erased until written over or until the [CLEAR SAV/RCL] softkey is utilized from the [SYSTEM] menu.

External storage

A permanent copy of the instrument configuration and calibration may be made utilizing the external storage capabilities of the HP 8757D and an external disk drive. The [SAVE] and [RECALL] functions access the external storage menus as well as the internal storage registers. For more information refer to chapter 6, External disk Save/Recall. These external storage capabilities allow the user to increase productivity by concentrating on making measurements, as opposed to repeatedly setting up the same instrument configurations.

Step six: measure device under test

After the test setup is calibrated, and the device has been connected, the trace displayed will present a normalized measurement of the device being tested.

Optimizing trace display

To optimize the presentation of data, the scale per divisions, and/or reference level and position may be adjusted. Selecting [SCALE] displays the [AUTOSCALE] softkey which provides a quick convenient method for adjusting these functions. [SCALE] also allows the user to change the scale per divisions by utilizing the keypad, knob, or step keys on the front panel. Reference functions may be adjusted separately by selecting [REF LEVEL], or [REF POSN] from the [REF] menu. Changes may be entered via the keypad, knob, or step keys.

SWR and AUX display modes

The HP 8757D provides the user a choice of display formats. Reflection measurements may be displayed in standing wave ratio (SWR) or return loss (dB). The default format following preset is return loss. To make measurements in the SWR format select [TRC FMT SWR dB] from the [DISPLAY] menu.

The [AUX] softkey allows the user to measure a voltage incident on the ADC IN connector on the rear panel of the analyzer. This input voltage must be in the -10 to +10V range. The active channel displays this measurement as voltage versus frequency. This function provides a user with the means to measure voltage controlled devices such as attenuators and oscillators, enabling the analysis of the device's output power versus the control voltage. To access the AUX function, select the [MEAS] hardkey and press [MORE] until the [AUX] softkey appears.

Utilizing cursor and marker functions

The [CURSOR] key activates the cursor on all displayed channels. The cursor is identified by a "c" on an inverted triangle above each trace, it remains the active function until one of the other functions or instrument state keys is selected. The cursor value for each trace is presented in the mode label area above the grid. How power is presented is determined by the measurement and display mode selected for each channel; dB represents the difference between two inputs (ratio measurement or current measurement minus the stored reference), whereas dBm represents the absolute power at the chosen input. Use the front panel knob to move the cursor to the desired location on the trace. The measurement value (power and frequency) of the active trace will be displayed in the active entry area of the display.

The cursor menu contains several useful functions that can simplify many measurement procedures, thus reduce measurement times and increase productivity. These features are best illustrated in the transmission and reflection sections (chapters 2 and 3 respectively).

The HP 8757D also has the capability of displaying markers generated by the HP 8350B sweeper and the HP 8340B/8341B and HP 8360 series synthesized sweepers. These sources have independent, continuously variable markers, which may be adjusted via the knob, step keys, or data entry keyboard on the source. The active marker's number is presented on an inverted triangle on top of the displayed traces; other markers are displayed below the traces with their representative marker numbers beneath the triangle.

The markers may be manipulated while the cursor function is on, the cursor will remain active (identified by a "c") and accessible via the analyzer's front panel. If the cursor is turned off, the active marker's power and frequency will be presented in the mode and the frequency label areas respectively. When the cursor is on, the markers will be visible but without displaying any measurement data. The marker's utility is enhanced by several marker functions, such as marker sweep [MKR SWEEP] and marker to center frequency [MKR→CF]. A marker difference function [MKR Δ], computes and displays the difference between two markers.

Step seven: output results

Create a permanent record of the measurement by plotting the results to a plotter or a printer via HP-IB. The plotter/printer buffer facilitates efficient hardcopy outputs of your measurement data, by releasing the analyzer to the user within 5 seconds. Results may also be stored on an external disk. The HP 8757D allows the user to control these external peripherals without connecting an external controller.

To obtain a hard copy output of the current display, selecting [PRINT] or [PLOT] in the [SYSTEM] menu will offer a number of printing and plotting options (displayed in the menus below).

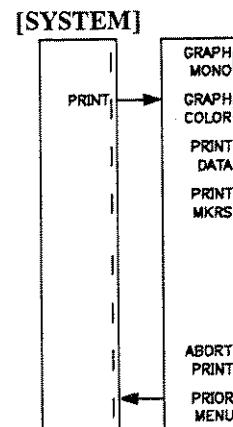
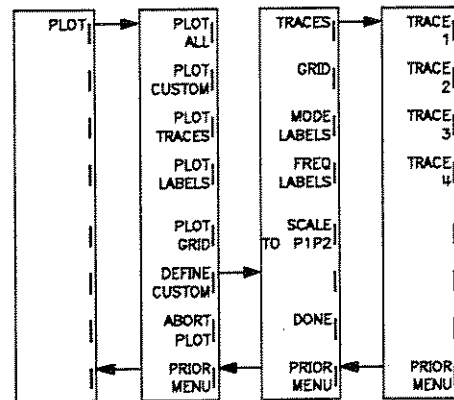

[PLOT ALL] plots everything currently displayed except for the softkey menu and the number of points. The user may also choose to plot only specific parameters (i.e. [PLOT TRACES] ...), or if repeated plots utilizing the same display parameters are necessary, a custom plot may be specified. [DEFINE CUSTOM] allows the user to select the display parameters for custom plots, then selecting [PLOT CUSTOM] will output the results with the same format each time. The [SCALE TO PIP2] option in the [DEFINE CUSTOM] menu allows the user to expand the plot to fill up the page, in this case the labels are plotted inside the grid.

In the HP 8757D's [PRINT] menu, [GRAPH MONO] allows the user to print the displayed information to any compatible printer in black and white. [GRAPH COLOR] may only be utilized with a HP PaintJet (color) printer. Both of these functions will output everything displayed except for any messages in the display's active entry area and the softkey menu.

Selecting [LABELS] in the [SYSTEM] menu offers the user the choice of turning on or off the labels or title of the current display prior to printing. [PRINT DATA] will output each point on the trace in tabular form. [PRINT MARKERS] will list just the information relating to markers and cursors currently displayed.

Transmission measurements with the HP 8757D

This chapter demonstrates many of the features of the HP 8757D. A complete measurement setup is given for each example, following the same basic measurement sequence of chapter one. The examples provided in this document represent typical scalar network measurements. This section describes transmission measurements of insertion loss, 3 dB bandwidth, peak-to-peak ripple, and gain compression. Some of the features presented are: averaging, smoothing, adaptive normalization and power sweep.

Modify the instrument setups shown to suit your particular needs. For further information on any of the measurements shown, refer to the appropriate operating manual for the most complete description of the analyzer's operating modes, parameters, etc.

Basic system configuration

The HP 8757D analyzers can measure transmission using any of the four display channels with either a single detector at input A, B, C (HP 8757D Option 001) or R, or two detectors in a ratio measurement (i.e. A/R, B/R, etc.). In the simplest transmission setup the device attaches directly to the source, and the detector to the output of the device. This configuration will produce accurate results when a leveled source is utilized with a low reflection test device. However, when source mismatches occur they can create power level variations which will produce system errors.

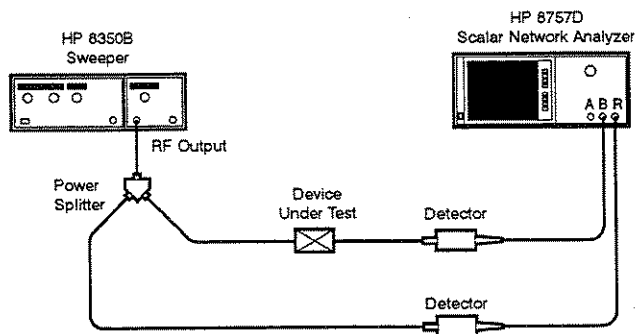

Ratioing provides an improvement in effective source match by eliminating the effects of source power variations common to both reference (R) and test inputs. This technique is particularly appropriate for measurement of devices with a low insertion loss, poor input match, or an unleveled source. Since active devices (devices with gain) usually require measurements with varying inputs, ratioing eliminates the need to recalibrate each time the power level is changed; also it reduces the ripple associated with source mismatches to which many active devices are particularly sensitive.

Measurement setup for insertion loss and gain

Insertion loss and gain are ratios of the output to input signals. When set up as shown below, the results can be read directly in decibels (dB).

Preset

Return the system to a known state, channel 1 active.

Connections

Connect the DUT to the network analyzer as shown in the previous configuration.

Controls

Setup the measurement.

Measurement

- [MEAS] [B/R] Sets up ratio measurement on channel 1.
- CHANNEL [2] Activate channel 2
- CHANNEL [2] Turn channel 2 off. Channel 1 becomes active channel.

Source parameters

- [CF] Activates the center frequency function.
- [10.24] [GHz] Sets center frequency to 10.24 GHz.
- [ΔF] Activates frequency span function.
- [2] [GHz] Sets frequency span to 2 GHz.
- [POWER LEVEL] Activates power level function.
- [10] [dBm/dB] Sets power level to +10 dBm.

Calibrate

Perform thru calibration.

[CAL]	Accesses calibration menu.
[THRU]	Sets up calibration; remove DUT, connect thru.
[STORE THRU]	Stores calibration in active channel's memory.
[DISPLAY]	Accesses display menu.
[MEAS-MEM]	Normalizes measurement trace.

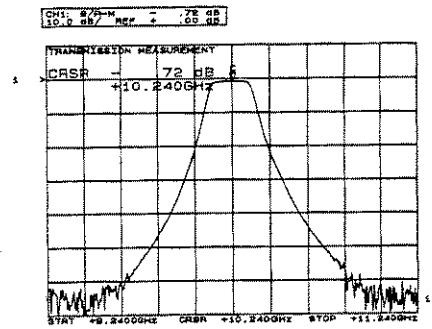

Save

Save the instrument states and calibration.

[SAVE]	Presents "SAVE REG" in the display's active entry area.
[1]	Saves instrument state and calibration in register 1.

Measurement

Reconnect the DUT.

[SCALE]	Activates scale function.
[AUTOSCALE]	Provides quick, convenient scaling of the measurement data.

Raising the reference position to the top half of the grid and adjusting the reference level to 0 dB sets the passband of the filter to the reference line, facilitating average insertion loss measurements and magnifying the passband region for flatness measurements without resetting the reference levels. The following sequence sets up the reference functions:

[REF]	Activates reference level function and displays menu.
[REF POSN]	Allows the user to change the position of the reference line.
[▲] or [▼]	Steps the reference line up or down to any of the major graticules.
[REF LEVEL]	Allows the user to change the position of the trace relative to the position of the reference line.
[0] [dBm/dB]	Sets the reference level to 0 dB.

The following figure shows the complete transmission response of the bandpass filter under test. The display exhibits several important filter parameters. The cursor functions provide a powerful tool for measuring specific points or the difference between two points. Note that the cursor value is displayed in the mode label area above the reference level value; the negative value indicates loss, a positive value would indicate gain.

Insertion loss

Insertion loss can easily be determined to 0.01 dB resolution, by utilizing the cursor to measure the magnitude at any frequency of interest. When the cursor is active, the magnitude and frequency of that point will be presented in the active entry area of the display.

Average insertion loss is determined by utilizing the scale and reference level functions to magnify the passband, and making the ripple symmetrical about the reference line.

[SCALE]	Activates the scale function.
[0.2] [dBm/dB]	Sets scale to 0.2 dB/division.
[REF]	Accesses reference menu.
[REF LEVEL]	Activates reference level function; use the front panel knob to move the trace such that the ripple is symmetrical about the reference line; read the average insertion loss in the active entry area of the display.

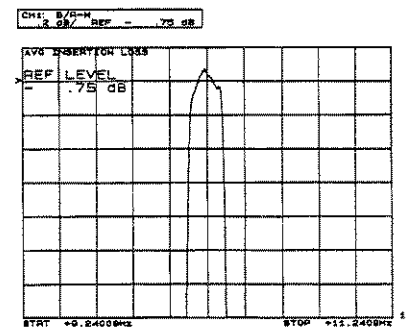

When finished, reset the reference level to 0 dB for the following measurements.

3 dB bandwidth

On the HP 8757D, bandwidth measurements are accomplished by selecting **[MAX]**, **[CURSOR Δ ON OFF]**, then moving the trace cursor to one side of the bandpass filter and locating the -3 dB point. Determine the frequency at that point, by turning **[CURSOR Δ ON OFF]** and noting the cursor value. Repeat the process to find the -3 dB point on the other side of the passband, then manually compute the bandwidth.

The HP 8757D's cursor search functions allow the user to determine the 3 dB bandwidth with only a few key-strokes.

[SCALE]	Activates scale function.
[AUTOSCALE]	Scales traces.
[CURSOR]	Turns cursor on, activates menu.
[SEARCH]	Activates search menu, displays current search value, default value equals -3 dB.
[BANDWIDTH]	Places cursor markers on the -3 dB points of trace, displays search value and bandwidth frequency span.

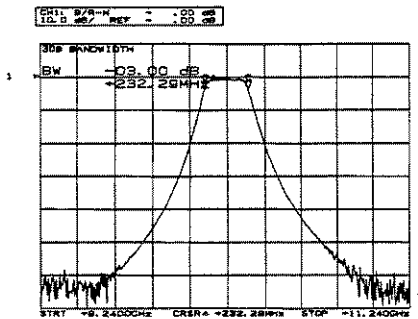

The search value and the bandwidth value are the same. To change the bandwidth value, select **[SEARCH]**, **[SEARCH VALUE]**, and enter the number on the keypad, followed by **[ENT]**. The user may also require frequency information at specific points. Selecting **[MAX]**, then **[CURSOR Δ ON OFF]**, **[SEARCH]**, and **[SEARCH RIGHT]** or **[SEARCH LEFT]** will move the cursor to the "search value" previously set. Then selecting **[CURSOR Δ ON OFF]** will display the frequency at that point.

Peak-to-peak ripple

Measuring peak-to-peak ripple requires magnifying the passband such that the difference between the peaks can be determined.

[SCALE]	Activates scale function.
[0.2] [dBm/dB]	Sets scale to 0.2 dB/division.
[CURSOR]	Activates cursor function.
[MAX]	Moves cursor to maximum point on trace.
[CURSOR Δ ON OFF]	Marks the cursor position; use the front panel knob to move the cursor to the minimum point on the trace, the active entry area of the display will present the magnitude (and frequency) of the difference between the two points.

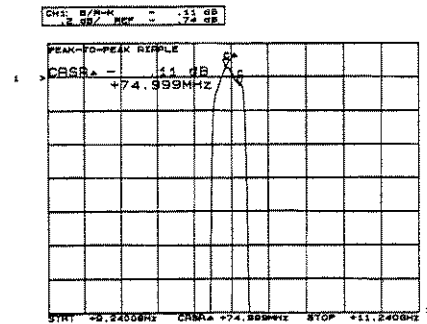

If more resolution is desired in the peak-to-peak measurement, the user may zoom in on the passband by selecting channel 2, then repeating the general measurement setup for channel 1, except replacing the **[ΔF]** with the span of the passband.

Out of band rejection

The wide dynamic range of the HP 8757D allows it to measure stopband rejection over 76 dB below the passband response. Maximum dynamic range requires proper selection of the measurement port power level and averaging factor. The **[MAX]** and **[MIN]** functions in the cursor menu allow the user to quickly determine the dynamic range of the device under test.

Usable dynamic range is the difference between the measurement port's output power and the HP 8757D's noise floor. Optimizing dynamic range therefore involves:

- choosing the optimum input and output power to the device.
- reducing the analyzer's noise floor.

Selecting the power level

The accompanying figures show how power test levels determine the available measurement range. In the first case, the output power of the source is -5 dBm. The device appears to have approximately 50 dB of rejection in the stopband. In the second case, the output power of the source is $+10$ dBm. Notice, this increases the measurable dynamic range to >65 dB. We have now demonstrated that the stopband rejection of this device is >65 dB.

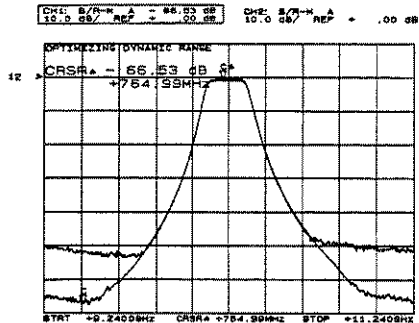

The user should ensure that the DUT's output power is within the measurement range of the analyzer. The analyzer can measure signals up to $+20$ dBm with the HP 85037 series precision detectors, and to $+16$ dBm with the HP 11664 and HP 85025 series detectors. On the low end, the analyzer can measure signals down to -60 dBm with the HP 11664 series and to -55 dBm (-50 dBm in DC mode) with the HP 85037 and 85025 series detectors.

When >80 dBm of dynamic range is required, Application Note 327-1 describes how to utilize a HP 8349B Amplifier and an external leveling loop to extend the dynamic range of your measurement system.

Averaging

Averaging can reduce random noise measured by the HP 8757D, by applying weighted averaging to successive traces. The averaging factor [AVG FACTOR] determines the number of sweeps over which the traces are averaged. This function improves the accuracy and resolution of the calibration and measurement traces. When averaging is on, each successive sweep flattens the noise floor of the analyzer until the sweep count reaches the averaging factor value. Users must be careful to adjust the device under test only after the averaging of the traces has settled and the value of the averaging factor has been reached. An "A" will be displayed in the center of the channel's mode label area when averaging is in use.

Averaging keystrokes

[AVG]	Accesses averaging menu.
[AVG ON OFF]	Turns averaging on.
[AVG FACTOR]	Displays current averaging factor value in active entry area, default value is 8; the value may be changed via the keypad, knob or step keys.
[RESTART AVERAGE]	Restarts the averaging algorithm.
[AVG ON OFF]	Turns off averaging function.

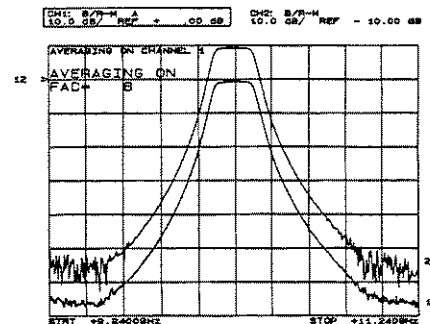

Smoothing

Although smoothing does not lower the noise floor, it can make noisy signals easier to interpret by reducing trace ripple. Smoothing is often likened to video filtering, and is different from averaging. Averaging computes each data point based on the average value during several sweeps. Smoothing computes each data point based on one sweep, but on the average of a window of several data points for the current sweep. The window or smoothing aperture is a percent of the swept frequency span, less than or equal to 20%.

Use smoothing with caution; too large a smoothing aperture may distort the data. The trace on channel 2 shows the response of a bandpass filter with no smoothing. The channel 1 trace shows the response with 1% smoothing. For this example, the 1% smoothing reduces the noise seen in the filter's reject band. Increasing smoothing beyond 1% will visibly distort the passband response. Notice the "S" in the mode label area indicating that smoothing is active for channel 1.

Smoothing keystrokes

[SPCL]	Accesses the special functions menu.
[SMOOTH ON OFF]	Turns smoothing on.
[SMOOTH APERT]	Allows the smoothing aperture to be changed; the default value is 5%.
[SMOOTH ON OFF]	Turns smoothing off.

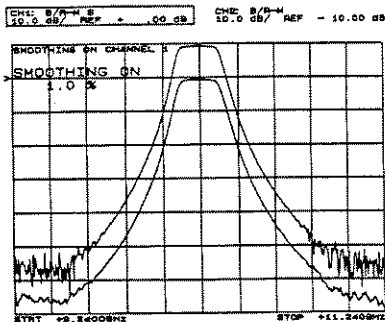

Adaptive normalization

This feature allows the user to reduce the frequency span of a measurement without having to recalibrate. Note that the resolution (the number of points) of the narrower frequency span is not changed as the trace is expanded. This function utilizes the calibration data stored in memory and interpolates between the original calibration points.

Adaptive normalization is only available for normalized traces (MEAS-MEM) or if MEM is selected in the display menu. An asterisk (*) is displayed in the mode label area when adaptive normalization is active. If the frequency span is increased beyond the original calibration span, the measurement becomes uncalibrated and the * is replaced with a U in the mode label area.

The following sequence demonstrates how to use the adaptive normalization function of the HP 8757D, and the marker functions of the HP 8350B sweeper and HP 8340B/8341B synthesized sweepers to expand and display a selected portion of a calibrated trace.

[SYSTEM]	Displays system menu.
[ADPT NRM ON OFF]	Activates adaptive normalization function; select prior to changing the frequency settings.
[M1]	Activates marker 1; enter the start frequency on the source via the knob above the marker key or the keypad.
[M2]	Activates marker 2; enter the stop frequency on the source.
[SHIFT] [M1]	Activates the source's marker Δ function; displays the amplitude and frequency differences in the mode label area and beneath the grid respectively.
[MKR SWEEP]	Displays an expanded trace which is swept from marker 1 to marker 2; changes the source's front panel settings to reflect the new frequency span.

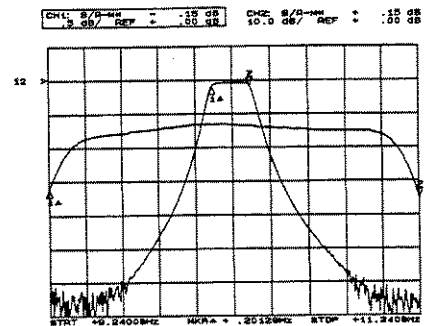

For other examples utilizing adaptive normalization, refer to the gain compression measurement section or chapter 5 (Alternate Sweep).

Measuring active devices

Active devices (devices with gain), usually require measurement at varying input power levels; a ratio configuration offers the best measurement results. Generally, the test setup for measuring gain and insertion loss are very similar. Although, it will be necessary to add attenuators to the measurement system if the input power to the detector exceeds +20 dBm. When an active device has a large gain, the input power needs to be appropriately attenuated during calibration and measurement.

When testing a modulation-sensitive device, the DC detection mode must be utilized. The HP 85025 series detectors operate in both AC and DC detection modes. The AC/DC mode softkey is located in the [SYSTEM] menu. Selecting [MODE AC DC] will turn off the square wave signal on the source and set the HP 85025 series detectors to DC mode. See the appendix for more information on AC versus DC detection.

Gain compression

Measurement of gain compression is useful for characterizing the power handling capability of active devices such as amplifiers. The 1 dB compression point of an amplifier is an indicator of the maximum output power possible before the gain non-linearity and its associated distortion becomes excessive. Measurements to this point have all been made with a constant input amplitude and swept test frequency. Gain compression measurements may be made in CW (single frequency) or swept modes. For the most accurate measurement at a particular frequency the source's power sweep mode may be utilized. This allows the user to characterize a device at a CW frequency as a function of input power.

The following sequence the power sweep function to measure gain compression.

Preset

Return the system to a known state, channel 1 active.

Connection

Utilize the insertion loss measurement configuration. Add attenuation where appropriate.

Controls

Setup the measurement.

Measurement

[MEAS] [B/R]	Sets up channel 1 for gain measurement.
CHANNEL [2]	Activates channel 2.
[MEAS] [B]	Sets up absolute output power measurement on channel 2.
[CHANNEL 4]	Activates channel 4.
[MEAS] [R]	Sets up absolute input power measurement.

Source parameters

[SHIFT] [CW]	Sets up display for gain and power versus input power at one frequency; set to desired frequency in amplifier range.
[POWER LEVEL]	Set start power.
[POWER SWEEP]	Enter the sweep range required to saturate the amp; e.g. 10 dB per sweep.

In the [SHIFT] [CW] mode, the source's SWEEP OUT drives the horizontal axis of the HP 8757D display to make this axis power instead of frequency.

Calibrate

Whereas the HP 8757D will require a thru calibration (channel 1) only once for the full range of the amplifier under test, then the adaptive normalization function may be utilized to adjust the calibration data to the selected CW frequency. The thru calibration required is described in the insertion loss and gain measurement setup section. The adaptive normalization function needs to be selected prior to the selection of the CW frequency, as shown below:

[SYSTEM]	Accesses system menu.
[ADPT NRM ON OFF]	Activates adaptive normalization function.

Source parameters

[SHIFT] [CW]	Enter desired frequency.
[POWER LEVEL]	Set start power.
[POWER SWEEP]	Enter sweep range.

Save

Save the instrument states and calibration as previously described.

Measurement

Reconnect the DUT.

Select channel 1 if it is not active. The cursor function should be utilized to find the maximum point on the trace. Then by activating the cursor Δ function the 1 dB point may be located, either by rotating the front panel knob or by utilizing the search function of the HP 8757D and changing the search value to -1 dB. When the search function on the HP 8757D is used, and the 1 dB compression point has been located, selecting the cursor hardkey turns off the delta cursor function so that the absolute output and input power levels are presented in the mode label areas of channels 2 and 4 respectively.

Most HP 8350B RF plug-ins in the power sweep mode can sweep up to 15 dB from the initial power set with [POWER LEVEL]. If the 1 dB compression point cannot be found, increase the power sweep setting or the start power. Remember not to exceed the maximum input power of the detector ($+20$ dBm), use attenuators where appropriate.

Once the measurement has been completed, a new frequency may be chosen. A convenient way to accomplish this is to set a step size in GHz, and increment the frequency by selecting [SHIFT] [CW] [\blacktriangle]. It is not normally necessary to adjust the power sweep parameters once they are set up. However, the sweeper must remain in CW mode.

The following figure displays gain and the absolute input and output power at 1 dB compression for a HP 8447D Amplifier. Channel 1 was calibrated across the 100 MHz to 1.5 GHz frequency range. The plug-in power level was set to -4 dBm, with a 10 dB and 6 dB pad attached to the output. The other measurement parameters may be determined from the figure.

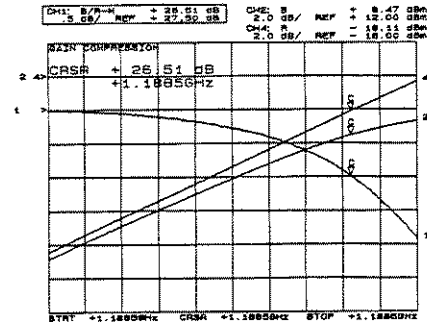

For more information on scalar analysis of amplifiers and mixers, refer to Application Notes 345-1 and 345-2 respectively.

Reflection measurements with the HP 8757D

The transmission measurements discussed in chapter 2 are only part of the network measurements picture. Measuring the return loss or SWR completes the device characterization. This chapter demonstrates how to perform reflection measurements with the HP 8757D.

Signal separation

Reflection measurements require the separation of the signal incident upon the input of the device from the device's reflected power. A signal separator such as a directional bridge or coupler provides a sample of the power traveling in only one direction; when it is connected as shown in the figure below, the reflected power is separated and measured independently of the incident power. Many types of directional bridges and couplers are available. They are differentiated by frequency range, directivity and connector type.

Device termination

Reflection measurements involve only one port of a test device. When a device has more than one port, it is critical that all of the unused ports are properly terminated in their characteristic impedance (e.g. 50 or 75 ohms). High quality loads or detectors with excellent return loss (such as the HP 85025E) should be used whenever possible, particularly with low loss devices. Otherwise, reflections off the unused ports will cause measurement errors.

Measurement accuracy

In reflection measurements, the accuracy of the final result is highly dependent on the signal separation devices, adapters, and the DUT terminations. Systematic errors such as the frequency response of the test setup, directivity, and mismatches degrade overall measurement accuracy. The HP 8757D's calibration routines can significantly reduce these measurement errors.

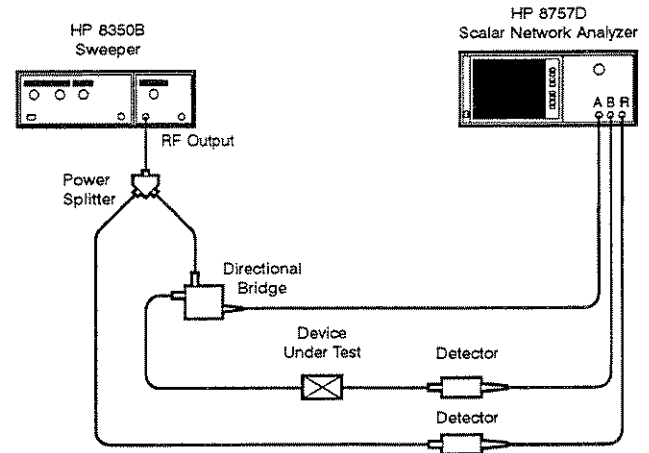

Measurement setup for return loss and SWR

The signal reflected from the DUT is most often measured as a ratio with the incident signal and can be expressed as return loss or SWR (standing wave ratio). These measurements are mathematically defined as:

$$\text{reflection loss} = \text{reflected/incident} = \rho$$

$$\text{return loss (dB)} = -20 \log \rho$$

$$\text{SWR} = (1 + \rho) / (1 - \rho)$$

Preset

Return the system to a known state, Channel 1 active.

Connections

Connect DUT as shown in figure.

Controls

Setup instrument.

Measurement

CHANNEL [2]	Activates channel 2.
CHANNEL [2]	Turns channel 2 off, activates channel 1.
[MEAS] [A/R]	Sets up reflection measurement on channel 1.

Source parameters

[CF] [10.24] [GHz]
[ΔF] [2] [GHz]
[POWER LEVEL] [10] [dBm/dB]

Calibrate

Perform reflection calibration.

[CAL]	Accesses calibration menu.
[SHORT/OPEN]	Sets up calibration; connect short.
[STORE SHORT]	Connect open.
[STORE OPEN]	Stores calibration in memory of active channel.
[DISPLAY]	Accesses display menu.
[MEAS-MEM]	Normalizes measurement trace.

Save

[SAVE] [2]	Save instrument state and calibration in register 2.
------------	--

Measurement

Reconnect DUT and adjust parameters to enhance usability of measurement data.

Return loss

The following figure displays the return loss of the band-pass filter. Since the return loss is high in the passband of the filter, only a small portion of the incident signal is being reflected off the filter. This indicates a good match between the filter and the test system impedance. The return loss in the filter's reject band is approximately 0 dB, which corresponds to an almost full reflection of the incident signal. A good passband filter should transmit the signal in the passband (i.e. small reflection, high return loss), while rejecting all signals outside of the passband (i.e. high reflection, low return loss).

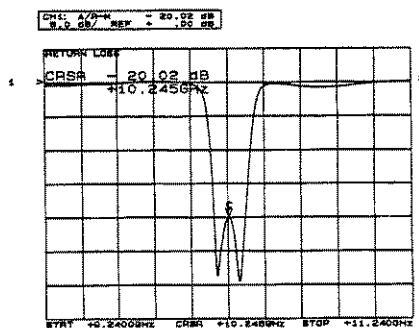

SWR

To display reflection data in terms of SWR, select [DISPLAY] then the [TRC FMT SWR dB] softkey. SWR is a unitless value, a SWR=1 corresponds to no reflection (perfect match), while an infinite SWR corresponds to 100% reflection (poor match). SWR is only available for ratioed or normalized measurements.

Simultaneous transmission and reflection measurements

Simultaneous insertion loss and return loss measurements are useful when adjusting the impedance match of a device for maximum power transfer. With the HP 8757D these measurements are easily accomplished. The following sequence demonstrates this feature.

Preset

Return the system to a known state, channel 1 active.

Connections

Connect DUT as shown.

Controls

Measurement

[MEAS] [A/R]	Sets up channel 1 for reflection measurement.
CHANNEL [2]	Activates channel 2.
[MEAS] [B/R]	Sets up channel 2 for transmission measurement.

Source parameters

[CF] [10.24] [GHz]
[ΔF] [2] [GHz]
[POWER LEVEL] [10] [dBm/dB]

Calibrate

Perform an open/short calibration on channel 1 and a thru calibration on channel 2.

Save

Measurement

Reconnect the DUT.

Adjust traces for the best data presentation with function keys.

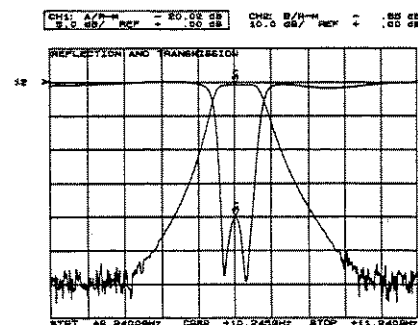

Limit lines

Limit testing is a measurement technique that compares measurement data to user defined constraints. Depending on the results of this comparison, the HP 8757D will display either pass or fail above the grid. Limit testing facilitates objective evaluation of your device's performance. Determining whether a filter meets its passband and stopband specifications or an amplifier meets its minimum gain specification is easily achieved utilizing limit lines that provide quick, convenient, and repeatable results. Limit testing also ensures that all devices are aligned and tested to the same specifications at each measurement station.

Limit testing is implemented by creating any combination of flat, sloping, and/or single point limit lines on the HP 8757D's display. Limit lines are defined in terms of upper and lower specifications for a particular frequency or band of frequencies. When combined, these lines represent the performance constraints of the device under test. Up to 12 limit segments are available for channels 1 and 2. They may be stored in the analyzer's internal save/recall registers 1 through 4. The following sequences will describe how to create each type of limit line and the sequence for the measurement of the passband filter previously shown.

Accessing the limit menu

- [SPCL] Accesses the special functions menu.
- [LIM LNS ON OFF] Turns on the limit line function.
- [ENTER LIM LNS] Accesses the limit line menu.

Creating flat limit lines

- [FLAT LIMIT] Sets up the flat limit function.
- [10.1] [GHz] Enters start frequency for first segment.
- [1] [dBm/dB] Enters upper limit.
- [−2] [dBm/dB] Enters lower limit.
- [10.3] [GHz] Enters stop frequency.

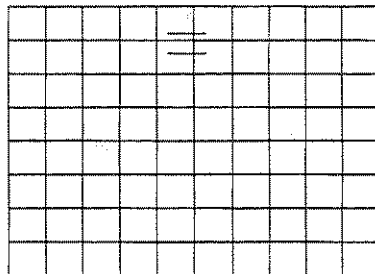

Flat limit lines are useful for testing insertion loss and passband ripple. The limit lines of the first segment should be displayed as soon as the stop frequency is entered. Once the first segment has been entered, the user may choose to start another segment by selecting the limit line type or terminate the limit line selection process by selecting [DONE]; the [SPCL] menu will reappear.

Creating sloped limit lines

- [SLOPE LIMIT] Sets up the slope limit function.
- [9.25] [GHz] Enters start frequency of segment.
- [−44] [dBm/dB] Enters start position of upper limit.
- [−50] [dBm/dB] Enters start position of lower limit.
- [10.1] [GHz] Enters stop frequency of segment.
- [1] [dBm/dB] Terminates the upper limit line.
- [−5] [dBm/dB] Terminates the lower limit line.

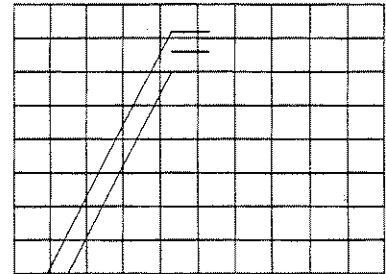

The user may find it difficult to span the entire side of a bandpass filter with one segment since the slope is not constant from the passband to the noise floor. It may be easier to set up the limit lines for one side with two segments (shortening the span) or, the user has the option of entering the limit lines for the entire span as two separate segments, one upper and one lower. To produce just an upper limit, the user may select [ENT] for the lower limit values of the start and stop frequencies.

*Available only on the HP 8757D. To deactivate a channel on the HP 8757E, press its hardkey until the channel turns off.

Creating point limits

- [POINT LIMIT] Sets up the point limit function.
- [10.4] [GHz] Enters the point's frequency.
- [1] [dBm/dB] Enters upper point position.
- [−2] [dBm/dB] Enters lower point position.

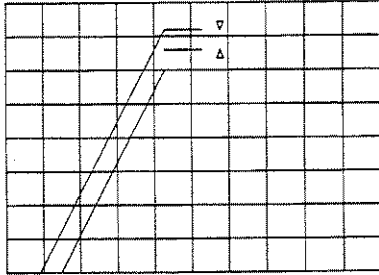

A single point limit is designated by two pointers. The upper limit points down, while the lower limit points up. The point limits are useful for testing the response of a device at specific test frequencies.

Editing limit segments

To edit a segment, select [EDIT SEGMENT] from the limit line menu and enter the segment number, the segment will be cleared erasing any data. A segment may not be modified; mistakes may only be corrected if the units (i.e. GHz or dB) for that particular entry have not been selected yet, then the [BK SP] (backspace) key may be utilized to erase the entry. To delete segments, select [DELETE SEGMENT] or [DELETE ALL LNS] from the limit line menu.

Creating limit lines for a bandpass filter

Preset

Return the system to a known state, channel 1 active.

Connections

Connect DUT as for insertion loss measurement.

Controls

Measurement

- [MEAS] [B/R]
- CHANNEL [2] Activates channel 2.
- CHANNEL [2] Turn channel 2 off, activates channel 1.

Source parameters

- [CF] [10.24] [GHz]
- [ΔF] [2] [GHz]
- [POWER LEVEL] [10] [dBm/dB]

Calibrate

Perform thru calibration.

Save

After the limit lines have been created the setup should be saved again.

Measure

Adjust trace for best data presentation.

- [SPCL]
 - [LIM LNS ON OFF]
 - [ENTER LIM LNS]
 - [FLAT LIMIT]
 - [8.24] [GHz]
 - [−55] [dBm/dB]
 - [ENT]
 - [9.6] [GHz]
 - [SLOPE LIMIT]
- } Enters the first segment from the table below.

The following table supplies the entries necessary to create the limit lines shown in the figure.

Seg	Type	Freq. (GHz)	Upper (dB)	Lower (dB)	Freq. (GHz)	Upper (dB)	Lower (dB)
1	FL	8.24	−55		9.6		
2	SL	9.6	−55		10.05	−1	
3	FL	10.17	0	−2	10.3		
4	SL	10.42	−1		10.9	−55	
5	FL	10.9	−55		11.24		

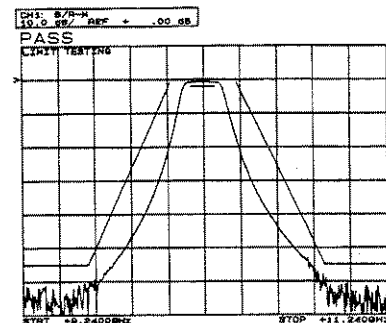

Alternate sweep

The alternate sweep function of the HP 8350B sweeper and the HP 8340B/8341B and 8360 series synthesized sweepers was designed for use with HP scalar analyzers, utilizing the 8757 System Interface. This function provides the ability to make real-time measurements, alternating on successive sweeps between the source's current front panel state and any of the states stored in memory. Simultaneously, the device's response may be displayed over two independent frequency ranges or two different power levels.

When tuning a filter, there is an alignment tradeoff between passband ripple and out of band rejection. Real-time adjustments may be made by displaying the passband on one channel and the full filter response on another channel, as shown in the figure below. Amplifier manufacturers may compare small signal gain to large signal gain for real time 1 dB gain compression measurements.

The following lists important considerations for setting up alternate sweep measurements:

- Only the source settings (frequency and power) of channels 1 and 2 are successively changed, the current analyzer settings remain the same.
- The active channel is swept over the source's current front panel settings, while the other channel is swept over the alternate register's source settings.
- The measurement parameters (the information in the mode label area) of channels 1 and 2 in the active register, should be set up the same as that in channels 1 and 2 in the register with which the active register will be alternated.
- The analyzer settings, such as the number of points, AC/DC detection mode, adaptive normalization, etc. of the active register, must be the same as the analyzer settings of the register that will be alternated.
- To change the source or measurement parameters of a trace, select the desired channel to make it active. The source's front panel settings for that channel will now be displayed. Changing the source parameters of a calibrated trace will cause it to become uncalibrated unless adaptive normalization is activated prior to reducing the frequency span.
- Channel 1 should be the active channel of one storage register, channel 2 should be active in the other register.

The following sequence presents a simultaneous measurement of a filter's passband ripple and out-of-band rejection.

Preset

Return the system to a known state, channel 1 is active.

Connections

Connect DUT as for insertion loss measurement.

Controls (Register 1)

Set up storage register 1.

Measurement

[MEAS] [B/R]
CHANNEL [2] [MEAS] [B/R]

Source parameters

[CF] [10.24] [GHz]
[ΔF] [2] [GHz]
[POWER LEVEL] [10] [dBm/dB]

Calibrate

With the HP 8757D, perform a thru calibration on channels 1 and 2, then follow the sequence below utilizing adaptive normalization.

When adaptive normalization is not utilized, channel 2 will require a thru calibration at the narrower frequency.

CHANNEL [2] Turns channel 1 off and activates channel 1

[SYSTEM] [ADPT NRM ON OFF]
[SAVE] [1]

Controls (Register 2)

Set up storage register 2. Only the source parameters are changed for this register.

Adaptive normalization is still on.

Measurement

CHANNEL [1] Turns channel 1 off and activates channel 2. Channel 2 is still set for B/R measurement.

Source parameters

[ΔF] [250] [MHz]
[SAVE] [2]

Measurement

Connect DUT.

[ALT n] [1] Alternates current display data stored in register 2, with the source parameters stored in register 1.

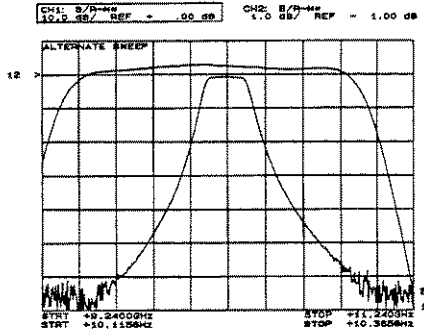

The traces should be scaled for optimal presentation of data. When the measurement is completed, pressing the [ALT n] hardkey again, will deactivate the alternate sweep function.

External disk save/recall

Using the external storage capabilities of the HP 8757D facilitates greater productivity by allowing the user unlimited storage of measurement setups and data. Frequently used test setups may be easily recalled for use by numerous test station operators, ensuring consistent device measurement.

When secure measurement environments are necessary, the measurement may be stored externally without displaying any frequency annotation (frequency blanking is described in the following chapter). Test station operators may then utilize the prepared measurement parameters without requiring direct knowledge of the frequency settings.

This chapter describes how to set up the disk drive, initialize the disk, and utilize the external disk store and recall functions of the HP 8757D.

Setting up the disk drive

When utilizing an external disk drive, the user must first set up the disk drive's HP-IB address, volume (for a hard disk drive), and unit number (for a floppy disk drive). Note that the HP 8757D can only access one drive at a time. The following sequence demonstrates the setup procedure.

Setting the disk's HP-IB address

- [LOCAL] [DISK] Accesses the address menu.
- [#] [ENT] Displays the disk's current HP-IB address in the active entry area of the display; default address is 0.
- [#] [ENT] Sets the new address to #.

Setting the disk's unit and volume numbers

- [SAVE] Accesses the storage menu.
- [SET UP DISK] Accesses the disk menu.
- [DISK UNIT] Displays the current disk number in the active entry area; usually 0 is the default value for the hard disk or the left-hand drive on multiple disk units.
- [#] [ENT] Sets the disk unit to #.
- [DISK VOLUME] Displays the current volume number; floppy disk drives should have a volume number of 0, the default value.
- [#] [ENT] Sets the volume number to #.

Initializing a blank disk

The HP 8757D provides the ability to initialize either a 3.5 inch floppy disk or a hard disk from the front panel. If the disk you wish to initialize is a 3.5 inch floppy, insert the disk into the appropriate disk drive prior to beginning this procedure.

Note: the following sequence will erase any information currently stored on the disk.

- [SAVE] Accesses storage menu.
- [SET UP DISK] Accesses disk menu.
- [INIT DISK] Sets up initialization.
- [INIT YES] Starts initialization.

Save/Recall functions

The user may store parts or all of the information currently displayed, on an external disk. The [SAVE] and [RECALL] hardkeys offer a number of choices for saving or retrieving data (as shown in the following menus).

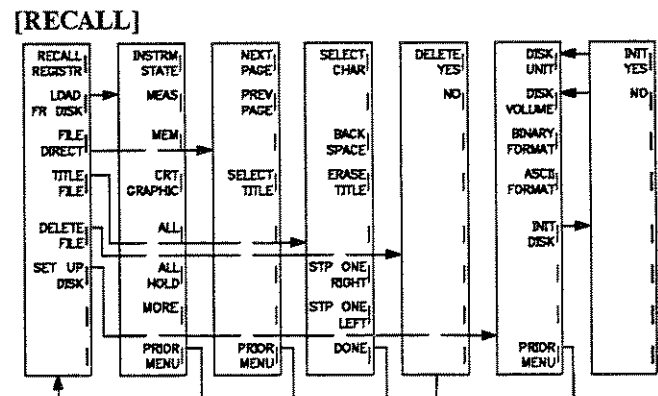
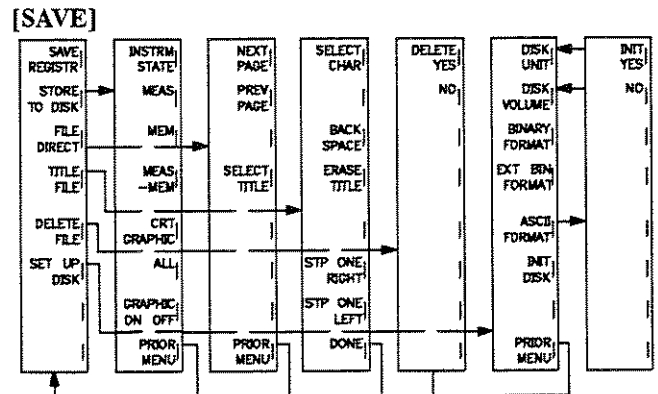

To store information on an external disk, each file must have a title with 8 characters or less. The **[TITLE FILE]** softkey is located in the **[SAVE]** and **[RECALL]** menus and uses the same title space as measurement titles.

When selected, the name of the last file stored will be displayed in the title area. Following preset, the file title defaults to "FILE1."

When the file name has been entered, selecting **[STORE TO DISK]** allows the user to store all or part of the information currently displayed. Once stored, the information may be recalled at any time by selecting **[RECALL]** and **[LOAD FR DISK]**. If a title identifying the measurement was present prior to selecting the file name, when the file is recalled from the disk, the measurement title will reappear in the title area.

If a different file is required, the **[FILE DIRECT]** softkey displays a directory of all the files that have been stored on that particular disk. The HP 8757D displays the contents of each file by creating sub-files for the instrument state, trace data, trace memory, and CRT graphics. The file name associated with each of the sub-files is displayed on the left side of the screen (as shown in the example below). Selecting any of the sub-files accesses all or part of the file depending on what option is chosen from the **[LOAD FR DISK]** menu.

TEST2A - ACTIVE FILE TITLE			NEXT PAGE
FILE TITLE	DESCRIPTION	NUM. OF POINTS	PREV PAGE
TEST1A	BINARY Instrum State		
TEST1A	BINARY Measurement Chan 1	401	
TEST1A	BINARY Measurement Chan 2	401	
TEST1A	BINARY Memory Chan 1	401	
TEST1A	BINARY Memory Chan 2	401	
TEST1B	BINARY Instrum State		SELECT
TEST1B	BINARY Measurement Chan 1	801	TITLE
TEST1B	BINARY Measurement Chan 2	801	
TEST1B	BINARY Memory Chan 1	801	
TEST1B	BINARY Memory Chan 2	801	
--▶ TEST2A	BINARY Instrum State		
TEST2A	BINARY Measurement Chan 1	1601	
TEST2A	BINARY Memory Chan 1	1601	
	END OF DIRECTORY		
			PRIOR MENU

Sample file directory

The following sequence demonstrates how to store and retrieve data using an external disk drive.

- [SAVE]** Accesses the storage menu.
- [TITLE FILE]** Accesses the title file menu.
- [ERASE TITLE]** Allows the entry of a new file name.
- [SELECT CHAR]** Selects the letter at the cursor on the display; use the front panel knob to move the cursor up and down the alphabet.
- [DONE]** Terminates the title selection process; returns the user to the save menu.
- [STORE TO DISK]** Initiates the external storage function.
- [ALL]** Stores all the displayed information; the user may choose to store only a portion of the current information by selecting one of the other options.
- [RECALL]** Accesses the recall menu.
- [FILE DIRECT]** Displays a directory of files stored on the disk.
- [SELECT FILE]** Selects the file title at the cursor; use the front panel knob to move the cursor up and down the file directory.
- [LOAD FR DISK]** Initiates the external recall function.
- [ALL]** Retrieves all of the file information; the user may choose to retrieve only a portion of the file by selecting another option.

Special functions

Color selection

One of the notable characteristics of the color selection function is the flexibility afforded the user to match his or her personal preferences. Each of the displayed notations such as the channel information, warnings and labels, as well as the grid and background may be adjusted individually. For those desiring a monochrome display, that is also available by the selection of a softkey.

Color selection is a global function, it is not affected by preset, or recalling a measurement from an internal storage register. When a file is retrieved from an external disk, the color selections stored in that file will be retrieved.

The display colors have been optimized to present the most pleasing and effective display. If the color selection must be changed, the HP 8757D allows quick modification via a color list menu. The color list provides access to 7 default colors (white, black, yellow, blue, salmon, red, and green).

All the color selection menus are accessed via the **[ADJUST DISPLAY]** softkey in the **[DISPLAY]** menu, as shown in the following layout of the color menus.

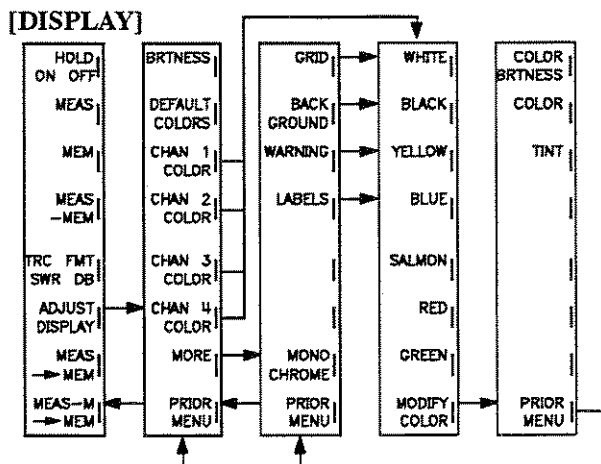

If the modification of the default colors is necessary, the user may select the **[MODIFY COLOR]** softkey at the bottom of the color list menu. It allows the user to change the color of a particular item (e.g. channel 1) by adjusting the tint, color and/or brightness.

In monochrome mode, the active trace is displayed with greater intensity than other traces. Once in monochrome mode, select **[ADJUST DISPLAY]**, then **[DEFAULT COLORS]** to reactivate the color mode.

Frequency blanking

The frequency blanking function in conjunction with the 8757 System Interface, allows the user to operate the analyzer in a secure mode by deleting all frequency annotation on the analyzer and the source. Once the **[FRQ LBL OFF]** softkey has been selected from the **[SYSTEM]** menu, frequency annotation may not be reactivated until the instrument is preset. Storing information in the internal registers or on an external disk with frequency blanking enabled, guarantees that frequency blanking will still be active when it is retrieved, even if the analyzer was preset prior to the recall operation. The following sequence activates the frequency blanking function.

- [SYSTEM]** Accesses system menu.
- [LABELS]** Accesses labels menu.
- [FRQ LBL OFF]** Deactivates frequency annotation on the analyzer and the source.

To disable the frequency blanking function, select **[PRESET]**.

AC versus DC detection

There are two methods used to detect microwave signals for display and measurement with scalar network analyzers. AC detection uses a modulated RF signal, providing accurate and stable measurements by minimizing unwanted signals. DC detection, which utilizes an unmodulated RF signal is most useful for modulation-sensitive devices. This section describes the capabilities and advantages of each mode. For further information on AC/DC detection with scalar analyzers, refer to: Product Note 8757-1, "Using AC detection with the HP 8757 scalar network analyzers."

The AC detection mode uses a 27.778 kHz square-wave modulated source. The square wave is demodulated by the detector and only the modulated envelope is passed to the scalar analyzer. At the analyzer, the demodulated signal is AC coupled into the log amplifiers then digitized. There are four main benefits of AC detection in scalar network measurements: 1) broadband noise is rejected, 2) undesired RF signals are not detected, 3) thermal effects are minimized, and 4) fast sweep times are possible even at low power levels.

The DC detection mode does not require any source modulation, the detectors respond to all the signals present. The HP 85025, 85026, and 85037 series detectors operate in AC or DC mode. When the analyzer is in DC mode, the detectors chop the signal after detection to provide the 27.778 kHz signal that the analyzer processes. The receiver circuitry is identical in both modes. The HP 8757 DC detection process offers the speed advantage of AC detection, since the receiver is not limited by the settling time of the log amplifiers at low power levels. The following figure presents a comparison of the detection processes for AC and DC modes (1. AC detection, 2. DC detection).

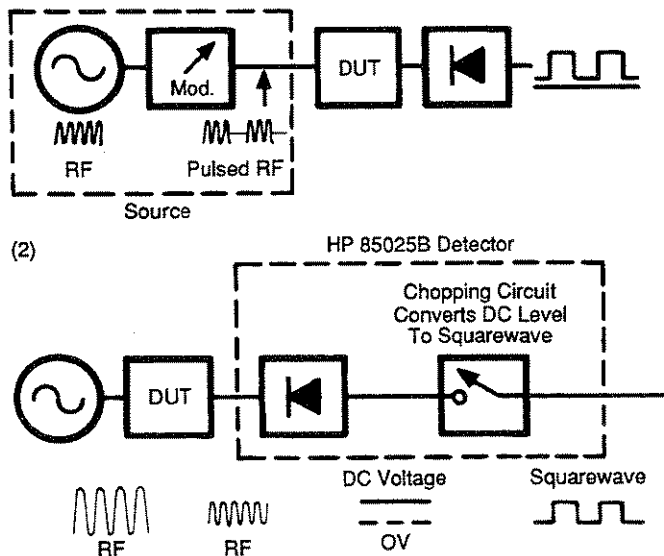

AC detection

The HP 8757D receiver (the log amplifiers in the analyzer) effectively functions like a tuned AC voltmeter operating at 27.778 kHz. In many applications, such as measurement of high-gain limiting amplifiers, noise will be present along with the desired signal being measured. This type of interference can reduce the effective dynamic range of the measurement system by raising the noise floor. In AC detection mode the analyzer is sensitive only to the signals that have the appropriate square wave modulation. Since only the desired signal is modulated at the source, the noise and other non-modulated RF signals are ignored, resulting with a true representation of the performance of the device under test.

Temperature changes can have a dramatic effect on measurements in DC mode, since they may induce a DC voltage offset at the diode's output. AC detection minimizes this problem by measuring only the modulated RF signal, thus ignoring the DC offset. Detector sensitivity to thermal change is a primary concern when measuring device performance as a function of temperature, particularly at low power levels (less than -40 dBm).

AC detection is the best broadband measurement technique for mixer testing. The presence of high-level LO feedthrough at the IF port of the mixer under test will impact the accuracy and dynamic range of the scalar analyzer, if DC detection is used. When the analyzer is operated in AC detection mode, the effect of the LO feedthrough is minimized by modulating the RF signal and leaving the LO signal un-modulated, thus the detector will respond only to the modulated IF.

Using DC detection

Certain devices require DC detection mode for the best results. Amplifiers with automatic gain control (AGC) are adversely affected by the modulation in AC detection mode. The leveling circuitry unsuccessfully tries to adjust the gain to track the modulation, the resulting square wave is distorted, degrading the scalar analyzer response. Other modulation sensitive devices include: amplifiers with slow responding self bias, devices with high gain at very low frequencies (<1 MHz), and devices with very narrow bandwidths (<1 MHz).

Absolute power (dBm) measurements may be more accurate in DC detection mode, since the measurement is not subject to variations in source modulation. Also, DC mode is more easily referenced to a power meter; in AC mode the power meter reading would be nominally 3 dB lower than the scalar analyzer reading, due to the square wave modulation of the source.

Symbols

[ADJUST DISPLAY], 25
[AUTOSCALE], 7
[AVG], 13
[CLEAR SAV/RCL], 7
[CURSOR], 8, 12
[DEFINE CUSTOM], 9
[DISPLAY], 25
[ENT], 4
[GRAPH COLOR], 9
[GRAPH MONO], 9
[LABELS], 9
[MAX], 12
[MEAS], 5
[MEAS-MEM], 7
[MIN], 12
[MODIFY COLOR], 25
[PLOT CUSTOM], 9
[PLOT], 8
[POWER CAL], 6
[PRINT MARKERS], 9
[PRINT], 8
[RECALL], 7, 23
[REF LEVEL], 11
[REF POS'N], 11
[REF], 11
[SAVE], 7, 23
[SCALE TO PIP2], 9
[SCALE], 7
[SPCL], 14, 19

A

Absolute power calibration, 6
 AC/DC detection, 26
 Active channel, 3
 Active devices, 15
 Active entry area, 3
 Alternate sweep, 21
 Aperture, 14
 AUX, 7
 Averaging, 13

B

Bandwidth, 3 dB, 12
 Basic system configuration, 5

C

Color selection, 25
 CRT display, 3

D

Data entry, 4
 Default colors, 25
 Default Conditions, 5
 Device termination, 17
 Disk setup, 23
 Display menu, 3

E

External storage, 23

F

Frequency blanking, 25
 Front panel, 3
 Function keys, 3

G

Gain compression, 15
 General measurement sequence, 4

I

Initializing a blank disk, 23
 Insertion loss, 11
 Instrument State keys, 4

L

Limit lines, 19

M

Marker, 14
 Markers, source, 8
 Measure device under test, 7
 Measurement accuracy, 17
 Mode labels, 3
 Monochrome mode, 25

N

Noise reduction, 13

O

Optimizing dynamic range, 12
 Optimizing trace display, 7
 Out of band rejection, 12
 Output power, gain measurements, 15
 Output results, 8

P

Peak-to-peak ripple, 12
 Preset, 4, 5

R

Reflection measurement calibration, 7
 Reflection measurements, 17
 Return loss, 18

S

Signal separation, 17
 Smoothing, 14
 Status notations, 3
 Storing information externally, 23
 Storing information internally, 7
 SWR, 7, 18

T

Transmission measurement calibration, 6

U

u – uncalibrated, 14

W

Window, smoothing, 14

1
2
3
4
5
6
7
8
9
10
11
12
13
14
15
16
17
18
19
20
21
22
23
24
25
26
27
28
29
30
31
32
33
34
35
36
37
38
39
40
41
42
43
44
45
46
47
48
49
50
51
52
53
54
55
56
57
58
59
60
61
62
63
64
65
66
67
68
69
70
71
72
73
74
75
76
77
78
79
80
81
82
83
84
85
86
87
88
89
90
91
92
93
94
95
96
97
98
99
100



Operating Reference
HP 8757D Scalar Network Analyzer



HP Part No. 08757-90169
Printed in USA March 1993

Notice.

The information contained in this document is subject to change without notice.

Hewlett-Packard makes no warranty of any kind with regard to this material, including but not limited to, the implied warranties of merchantability and fitness for a particular purpose. Hewlett-Packard shall not be liable for errors contained herein or for incidental or consequential damages in connection with the furnishing, performance, or use of this material.

© Copyright Hewlett-Packard Company 1993

All Rights Reserved. Reproduction, adaptation, or translation without prior written permission is prohibited, except as allowed under the copyright laws.

1400 Fountaingrove Parkway, Santa Rosa CA, 95403-1799, USA

Operating Reference

Added Benefits of the HP 8757D (Revision 5.1 and above)

The HP 8757D provides all of the same features as the HP 8757A and HP 8757C, but also provides the following features:

- improved absolute power accuracy with Option 002 50 MHz power calibrator
- compatibility with HP 85037A/B precision detectors in addition to all HP scalar detectors and bridges
- improved accuracy for mixer measurements from the detector frequency function
- Detector Offset:
 1. extended amplitude display range with detector offsets up to ± 60 dB
 2. the ability to measure a detector offset with the power calibrator to compensate for RF attenuators
 3. detector offsets are zeroed at preset
- four channel keys for easier menu use and access (channel number keys toggle the channels active and inactive)
- four display formats have uncoupled scale factors and reference values:
 1. **MEM**
 2. **MEAS**
 3. **MEAS-MEM** and
 4. **SWR**
- SWR display is allowed on any channel
- limit lines may be used with any number of trace points for any channel
- improved measurement speed
- cursor frequency readout for applications where an HP-IB sweeper is not used (frequencies are set by labels **START FREQ** and **STOP FREQ**)
- data recalled from disk may be reformatted or smoothed

Added Benefits of the HP 8757D (Revision 6.1 and above)

The HP 8757D (revision 6.0) provides all of the same features as the HP 8757D (revision 5.1) plus the following features:

- improved measurement speed
- clock feature (appearance of date and time on hardcopies and disk files)
- HP 83750 Series source compatibility
 - interpolated markers
 - ten available markers
 - improved frequency accuracy

Using this Reference

Use this reference to help you operate the analyzer locally. For additional information, see the *User's Guide*, also included in this section (Local Operation). The *User's Guide* describes general measurement setups and includes typical measurement examples.

This document provides the following information:

- HP 8757D operating features:
 - front and rear panel features
 - hardkey operation
 - softkey operation
 - softkey menu structure maps
- operator's check
- measurement applications

Finding a **Hardkey** Description

This document divides the front panel keys (hardkeys) into the functional groups labeled on the analyzer front panel.

- CHANNEL
- FUNCTION
- ENTRY
- INSTRUMENT STATE

To find a front panel key description:

1. Locate the key in the index.
2. Turn to the page listed for that key.

Finding a **Softkey** Description

When you press most front panel keys, one or more softkey menus is displayed. To find a softkey description:

1. Locate the key in the index.
2. Turn to the page listed for that key.

Softkey descriptions, included with each front panel key description, appear in the order in which the analyzer displays the softkeys, from the top to the bottom.

MORE

This softkey presents the next menu layer.

PRIOR MENU

This softkey displays the previous menu.

Contents

1. Front Panel Features	
CRT	1-3
HP-IB STATUS	1-6
Detector Inputs	1-6
Power Calibrator	1-7
2. CHANNEL	
3. ENTRY Area	
4. FUNCTION	
MEAS — Measurement Menu	4-2
DISPLAY — Display Menu	4-4
Horizontal Display Resolution	4-7
Display Resolution	4-7
Measurement Resolution	4-7
SCALE — Scale Menu	4-9
REF — Reference Menu	4-10
CURSOR — Cursor Menu	4-11
.	4-11
Cursor Interaction with Source Markers	4-11
Applications for Analyzer Cursors	4-11
Applications for Source Markers	4-12
Source Capabilities	4-12
AVG — Average Menu	4-14
CAL — Calibration Menus	4-15
Self-Calibration	4-21
Autocalibration	4-22
Temperature Compensation	4-22
SPCL — Special Menu	4-23
5. INSTRUMENT STATE	
SYSTEM — System Menus	5-2
LOCAL — Local Menu	5-10
Changing a Default Address	5-10
SAVE — Save Menus	5-11
RECALL — Recall Menus	5-17
PRESET — Preset Key	5-21
Analyzer	5-21
Source	5-22
Plotter	5-22
Printer	5-22

Disk Drive	5-23
Unchanged Analyzer Conditions	5-23
6. Rear Panel Features	
A. Operator's Check	
Equipment Required	A-1
Description	A-1
Procedure	A-2
B. Softkey Menu Structure Maps	
C. Performing an External Calibration	
Performing an External Detector Calibration with an HP 85025C	C-1
External Detector Measurement Calibration	C-1
Equipment required:	C-1
AC versus DC Measurement Calibration	C-2
Changing a Stored Measurement Calibration	C-3
Uncalibrated Operation	C-3
Zeroing	C-3
D. Measurement Applications	
Mixer Measurements	D-1

Index

Figures

1-1. The HP 8757D Front Panel	1-1
1-2. The Analyzer CRT	1-3
1-3. Mode Labels Description	1-4
1-4. HP-IB STATUS Indicators	1-6
1-5. Detector Inputs	1-6
1-6. Power Calibrator	1-7
2-1. CHANNEL Keys and Channel Menu	2-1
3-1. Knob, STEP Keys and Numeric Keypad	3-1
4-1. FUNCTION Keys	4-1
4-2. MEAS Key and Measurement Menus	4-2
4-3. DISPLAY Key and Display Menus	4-4
4-4. SCALE Key and Scale Menu	4-9
4-5. REF Key and Ref Menu	4-10
4-6. CURSOR Key and Display Menus	4-11
4-7. AVG Key and Average Menu	4-14
4-8. CAL Key and Calibration Menus	4-15
4-9. SPCL Key and Special Menus	4-23
5-1. Instrument State Keys	5-1
5-2. SYSTEM Key and System Menus	5-2
5-3. LOCAL Key and Local Menu	5-10
5-4. SAVE Key and Save Menus	5-11
5-5. Directory of Stored Files	5-14
5-6. RECALL Key and Recall Menus	5-17
5-7. PRESET Key	5-21
6-1. The HP 8757D Rear Panel	6-1
A-1. Operator's Check Equipment Set-up	A-2
B-1. HP 8757D Softkey Menu Structure Map	B-2
B-2. HP 8757D Softkey Menu Structure Map	B-3
B-3. HP 8757D Softkey Menu Structure Map	B-4
B-4. HP 8757D Softkey Menu Structure Map	B-5
D-1. Mixer Lab Equipment Set-up	D-1

Tables

1-1. Status Symbol Identification	1-4
1-2. Status Line Description	1-5
4-1. Minimum Sweep Time Versus Number of Points	4-7
4-2. Measurement Ranges and Resolution	4-7
4-3. Default Scale Per Division for Display Modes	4-9
5-1. Example Printout for PRINT DATA	5-4
5-2. Example Printout for PRINT MKRS	5-5
5-3. HP-IB Default Addresses	5-10
5-4. Source Settings Saved on Disk	5-12
D-1. Three Mixer Measurement Cases	D-2

Front Panel Features

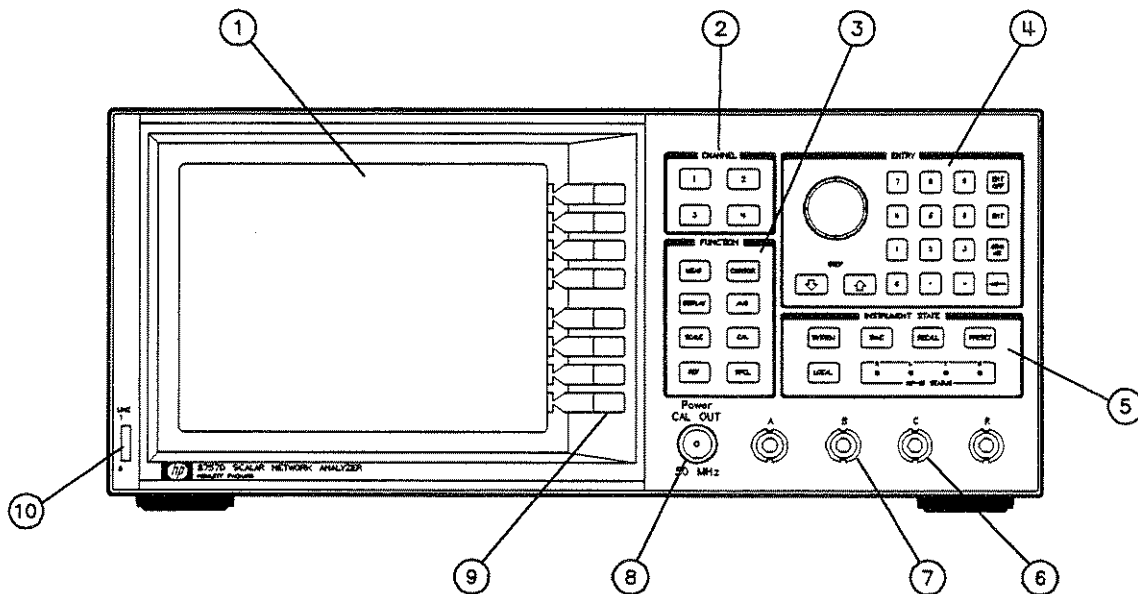

Figure 1-1. The HP 8757D Front Panel

- ① **CRT** Shows measurement annotation, softkey labels, data traces, and more.
- ② **CHANNEL** Displays a measurement channel and makes that channel active. When measurement channels are already displayed, these keys select the active measurement channel. The analyzer has five inputs (four inputs on the front panel and one auxiliary input on the rear panel) but can display up to four measurement channels.
- ③ **FUNCTION** Engages functions such as calibration and averaging.
- ④ **ENTRY** Includes knob, STEP keys, softkey menus, and numeric keypad for entering data.
- ⑤ **INSTRUMENT STATE** Controls system functions (such as plotting and defining titles) that apply to the entire instrument state, not just to a single channel.
- ⑥ **FOURTH DETECTOR INPUT** The fourth detector input is available on the Option 001 and Option 001/002 instruments only.
- ⑦ **DETECTOR INPUTS** Connect compatible detectors and directional bridges.

- ⑧ **POWER CALIBRATOR (Option 002)** Calibrates dynamic accuracy characteristics of HP 85037 Series detectors.
- ⑨ **SOFTKEYS** Present menu functions, and instrument status information.
- ⑩ **LINE**
Controls AC power to the analyzer.

CRT

The analyzer displays information in several areas (see Figure 1-2).

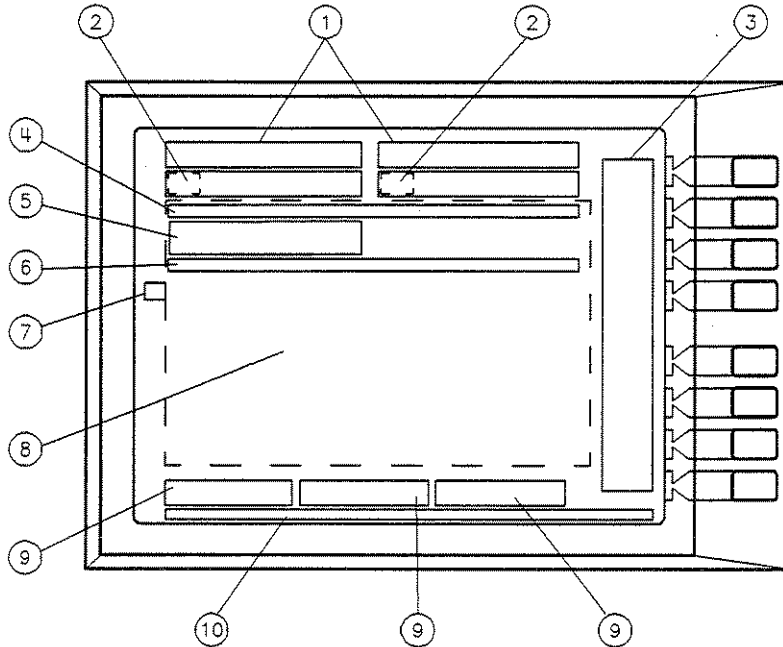

Figure 1-2. The Analyzer CRT

- ① **Mode Labels** Figure 1-3 shows each part of the mode labels area. For each channel turned on, this area shows the following:
- measurement mode (single input or ratio)
 - status symbols (indicating active functions, see Table 1-1)
 - cursor amplitude for HP 8350B, 8340/8341 Series, 83750 Series, or 8360 Series active marker amplitude
 - scale per division
 - reference level value

The following locations show mode labels:

Left Side of CRT Right Side of CRT

Channel 1 Channel 2

Channel 3 Channel 4

A highlighted box encloses the active channel mode labels.

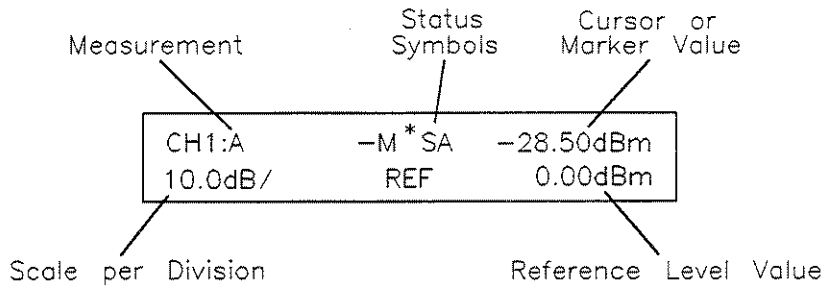

Figure 1-3. Mode Labels Description

Table 1-1. Status Symbol Identification

Status Symbol	Activated Feature	Function Key/ Instrument State Key
-M	MEASUREMENT-MINUS-MEMORY	DISPLAY
MEM	MEMORY	DISPLAY
A	AVERAGING ON	AVG
S	SMOOTHING ON	SPCL
*	ADAPTIVE NORMALIZATION ON	SYSTEM
U	ADAPTIVE NORMALIZATION ON (uncalibrated)	SYSTEM

- ② **Pass/Fail Indicators** Shows the pass/fail status based on the limit lines entered for channel 1 or 2. These indicators display *only with both channels 3 and 4 off*.
- ③ **Softkey Labels** Define the softkey functions for the menu shown. A label that is underlined and displayed with greater intensity indicates the engaged active channel function.
- ④ **Title Line** Shows the title that you have entered using the SYSTEM menu.
- ⑤ **Active Entry Area** Displays the last entry or HP-IB command function, except for preset (PRESET), measurement (MEAS), and display (DISPLAY).
- ⑥ **Message Line** Shows messages and warnings to the operator.
- ⑦ **Reference Line Position** Identifies the reference position for each channel with the channel number and a ">" symbol in the left margin of the graticule grid. You can position reference lines on major graticule lines.
- ⑧ **Data Display Area** Displays up to four measurement channel data traces.

- ⑨ **Frequency Labels** Displays the start, stop, and cursor (or source active marker) frequencies. The cursor frequency takes precedence over the active marker frequency. If you engage alternate sweep, the alternate sweep frequencies also appear.
- ⑩ **Status Line** Shows the current status of the analyzer (see Table 1-2). Blank entries do not apply to the current status.

Table 1-2. Status Line Description

AC	401	DETOFS ABCR	FRQ ABCR	MAN SS NON	SYSINTF OFF	UNCAL ABCR
①	②	③	④	⑤	⑥	⑦

- ① AC or DC detection mode
- ② Number of trace points:
 - 101
 - 201
 - 401
 - 801
 - 1601
- ③ Non-zero detector offset for each detector indicated
- ④ FRQ (ABCR) indicate that the DET FREQ (on/off) function is ON for the specified input (A, B, C, R).
- ⑤ Sweep mode other than standard swept mode:
 - MAN manual sweep mode
 - CW continuous wave (CW) sweep mode
 - NON nonstandard sweep mode
 - SS step sweep (available in HP 8340, 8360, and 83750 Series sources)
- ⑥ HP 8757 system interface is off
- ⑦ Uncalibrated condition for each detector (A, B, C, R) connected. This message occurs only when you turn autocalibration *off* (in the CAL menu), and an input drifts out of calibration (for more information see "Self-Calibration" in chapter 4).

HP-IB STATUS

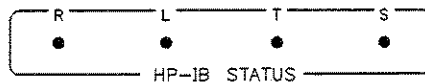

Figure 1-4. HP-IB STATUS Indicators

The HP-IB STATUS indicators (Figure 1-4) show the current status of the analyzer. The indicators do not update continuously. Several complete HP-IB operations can take place without any change in the displayed status.

Indicator	Analyzer Status
R	Remote operation
L	Listen mode
T	Talk mode
S	Service request (SRQ) asserted

Detector Inputs

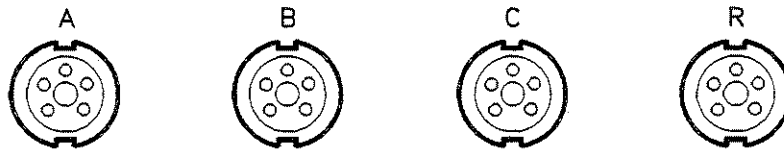

Figure 1-5. Detector Inputs

Figure 1-5 shows the analyzer's detector inputs. Each input has identical characteristics and allows connection of compatible detectors and bridges.

Input A is typically used to connect a directional bridge for reflection measurements.

Input B is typically used to connect a detector for transmission measurements.

Input C (found on Option 001 and 001/002 instruments only) is typically used to measure a fourth parameter, for example, where a device under test has more than one output.

Input R is typically used as the reference detector input for ratio measurements.

Power Calibrator

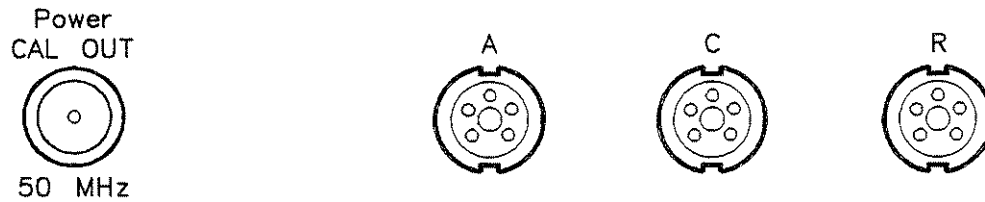

Figure 1-6. Power Calibrator

Figure 1-6 shows the Option 002 power calibrator output connector. Use the power calibrator (a multi-level 50 MHz reference) to calibrate the dynamic accuracy characteristics of HP 85037 Series precision detectors, as well as other HP detectors and bridges. See "Calibration Menus" in chapter 4.

CHANNEL

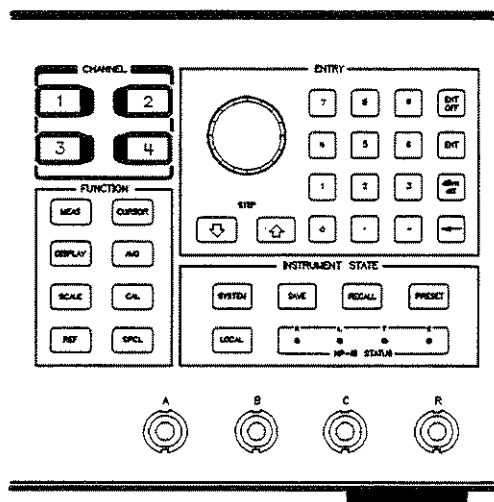

Figure 2-1. CHANNEL Keys and Channel Menu

Figure 2-1 shows the CHANNEL keys. A channel receives the data from the detector inputs and the analyzer displays it in a format designated by either the preset conditions or by the conditions you set from the front panel key entry.

If you press a CHANNEL key for an undisplayed measurement channel, the analyzer will display the channel and make that channel active. If you press a CHANNEL key for a displayed measurement channel, the analyzer will make that channel active. But, if you press a CHANNEL key for a displayed and active measurement channel, the analyzer will turn that channel off.

The analyzer can select data from up to five inputs (four inputs on the front panel and one auxiliary input on the rear panel) but can only measure up to four inputs at one time. The analyzer can only have one *active* channel at a time. A highlighted box encloses the active channel mode labels. Any function you select applies exclusively to the active channel but measurement data is updated to all channels simultaneously. At instrument preset, the measurements on channels 1 and 2 are displayed, with channel 1 active.

1 2 3 4 5 6 7 8 9 10 11 12 13 14 15 16 17 18 19 20 21 22 23 24 25 26 27 28 29 30 31 32 33 34 35 36 37 38 39 40 41 42 43 44 45 46 47 48 49 50 51 52 53 54 55 56 57 58 59 60 61 62 63 64 65 66 67 68 69 70 71 72 73 74 75 76 77 78 79 80 81 82 83 84 85 86 87 88 89 90 91 92 93 94 95 96 97 98 99 100



ENTRY Area

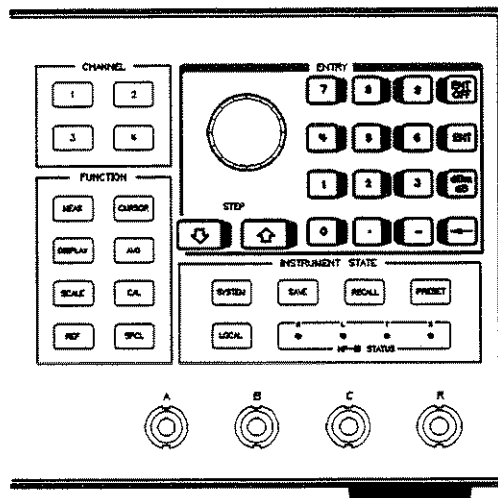



Figure 3-1. Knob, STEP Keys and Numeric Keypad

The **ENTRY** area consists of the **knob**, the **STEP** keys, and the **numeric keypad**. (See Figure 3-1.)

- Use the **knob** to change current values for various functions such as **SCALE** and **REF LEVEL**. Counter-clockwise rotation decrements the value; clockwise rotation increments the value.
- Use the **STEP** keys to increment or decrement the numerical value of a function.
- Use the **numeric keypad** digits, decimal points, and minus signs for numerical entries. Entries require using a terminator of **ENT** or **dBm/dB** (except for **SAVE** and **RECALL** entries).
- **ENT** terminates unitless entries such as averaging factors (non dBm).
- **dBm/dB** terminates numeric keypad entries for functions such as **SCALE** and **REF LEVEL**.

Note  deletes the last digit entered.



1 2 3 4 5 6 7 8 9 10 11 12 13 14 15 16 17 18 19 20 21 22 23 24 25 26 27 28 29 30 31 32 33 34 35 36 37 38 39 40 41 42 43 44 45 46 47 48 49 50 51 52 53 54 55 56 57 58 59 60 61 62 63 64 65 66 67 68 69 70 71 72 73 74 75 76 77 78 79 80 81 82 83 84 85 86 87 88 89 90 91 92 93 94 95 96 97 98 99 100



FUNCTION

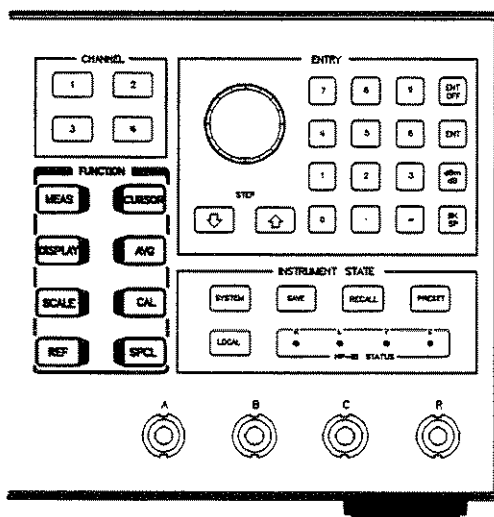

Figure 4-1. FUNCTION Keys

Figure 4-1 shows the FUNCTION keys. Use the eight FUNCTION keys to engage functions and present softkey menus that generally apply only to the active channel. These functions include:

- measurement modes
- display formats
- scale factors
- reference levels and positions
- cursor positioning
- averaging
- calibration
- special functions

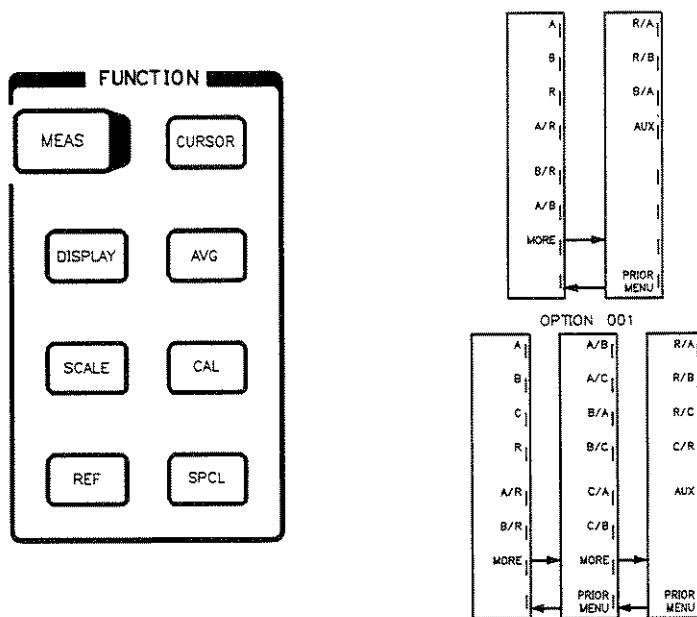

Figure 4-2. MEAS Key and Measurement Menus

The MEAS key presents the measurement menus (see Figure 4-2). You can select the analyzer to display either a single measurement channel or a ratio of channels.

For example:

- If you select A, the analyzer displays the measured value at input A (in dBm).
- If you select A/R, the analyzer displays the measured value at input A (in dBm) *minus* the measured value at input R (in dBm).

Because the values are in dBm, a logarithmic subtraction equals the linear division A/R, and the result is displayed in dB.

The softkey function you select applies *only* to the active channel.

Note

The analyzer can measure and display up to four of the five available inputs at one time (four inputs on the front panel and one auxiliary input on the rear panel).

The analyzer displays the selected measurement parameter in the mode labels area next to the channel number.

- When you press **PRESET** (the green INSTRUMENT STATE key), channel 1 then presets to measure input A, and channel 2 measures input B.
- In the mode labels area, A appears next to CH1: and B next to CH2:.

AUX selects a voltage input from the rear panel ADC IN (+10 to -10 V) connector. The active channel displays this voltage (instead of data from a single or ratioed detector input). You can use this function to observe the control voltage input to a voltage controlled device.

DISPLAY — Display Menus

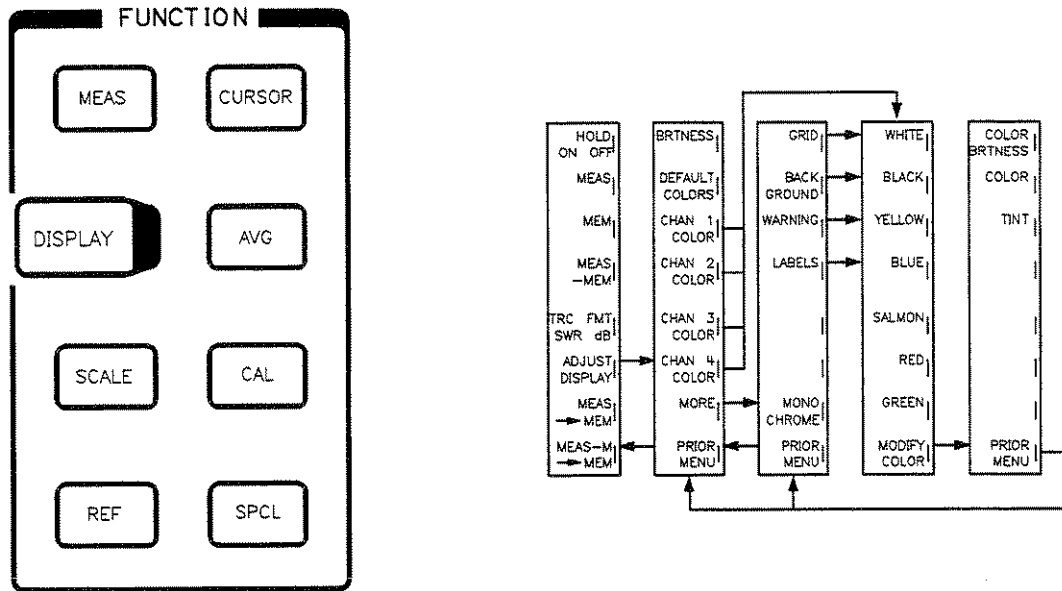

Figure 4-3. DISPLAY Key and Display Menus

The **DISPLAY** key presents the display menu (Figure 4-3), which allows you to control how the analyzer processes and displays measurement data. This menu lets you show the measurement, the data in the active channel memory, or the difference between the two. It also lets you enter the measurement (or the measurement-minus-memory) into memory.

This menu also allows you to define the colors used for analyzer display attributes such as the grid, the channel measurement traces, and the labels.

HOLD ON OFF freezes the active channel measurement data displayed on the analyzer.

MEAS shows the measurement data of the selected input (or ratio of inputs).

MEM shows the measurement data previously stored in the memory of that channel. When you engage this function, **MEM** appears in the status symbols section of the mode labels area for that channel.

MEAS-MEM shows the data previously stored in memory subtracted from the current measurement data (commonly used during calibration to produce a normalized trace). When you engage this function, **-M** appears in the status symbols section of the mode labels area for that channel.

TRC FMT SWR dB provides a choice of data formats for reflection data as either standing wave ratio (SWR) or return loss (dB). At preset, the data is in the return loss format.

You may select SWR for ratioed or normalized measurements on all channels and with any number of points.

Remember When you press any of these softkeys, the selected function is engaged only for the active channel, except for display adjustments.



ADJUST DISPLAY allows you to adjust the menus that display brightness and color.

BRTNESS lets you change the brightness (intensity) of the display. **BRTNESS:DISPLAY** appears in the active entry area, with the value last entered). 100% is equivalent to 100 nits (units of luminance), and is the specified brightness level at shipment. If you wish, use the front panel knob or numeric keypad to enter a new value. Terminate the entry with the **(ENT)** key. You can adjust the brightness value down or up (although the display quality is not specified above 100%). The maximum value depends on the individual display. Preset does not change the brightness level unless you set the level below a defined minimum. You can change the minimum brightness level (see the service manual for instructions).

DEFAULT COLORS sets all analyzer display attributes to the factory-defined default colors, which were scientifically chosen to maximize your ability to discern the difference between the colors, and to comfortably and effectively view the colors. These choices accommodate most people with color-deficient vision, and provide an easy-to-view contrast.

If the default colors do not accommodate special circumstances, you can make additional adjustments. The most frequent color deficiency is the inability to distinguish red, yellow, and green. You can usually eliminate confusion with these colors by increasing the brightness between the colors (see **COLOR BRTNESS**). If you need more contrast, you can vary the degree of whiteness of the color (see **COLOR**). Usually, minor changes fix the problem.

You can also select one of the 7 factory-defined colors available from the color list. See (**CHAN x COLOR**).

CHAN x COLOR select the channel (x = 1, 2, 3, or 4) whose attributes (measurement trace, mode labels, limit lines, and reference level marker) you wish to adjust.

When you select this softkey, the analyzer displays the factory-defined color list.

WHITE, **BLACK**, **YELLOW**, **BLUE**, **SALMON**, **RED**, and **GREEN** constitute the factory-defined color list. You can use any of these colors for any of the eight analyzer display attributes.

MODIFY COLOR selects the menu that lets you adjust a selected color.

Remember Because you can adjust the colors of all the analyzer display attributes, you can adjust the colors such that you cannot see an attribute against the background (such as red warning labels against a red background). The softkey labels, however, remain visible.



DISPLAY

COLOR BRTNESS changes an attribute's color brightness. When you press this softkey, the CRT displays the existing value set for that attribute. If you wish, use the front panel knob or numeric keypad to enter a new value for color brightness. As you change values, the attribute changes on the analyzer display. Press **ENT** to terminate the entry.

COLOR changes the degree of whiteness of the attribute's color (on a scale from white to pure color). Adjust this parameter the same way as **COLOR BRTNESS**.

TINT changes the attribute's hue. The continuum of hues on the color wheel range from red, through green and blue, and back to red. Adjust this parameter the same way as **COLOR BRTNESS**.

Note



Preset and power on/off do not affect color selection. Color changes and adjustments remain in effect until you change them in these menus. To return to a previously defined color, write down the numeric value of the color brightness, color, and tint, and enter the appropriate value for each parameter.

MORE displays the continuation of the color adjust selections.

GRID selects the analyzer display grid so you can modify its color from the factory-defined color list (**WHITE**, **BLACK**, **YELLOW**, **BLUE**, **SALMON**, **RED**, and **GREEN**).

BACKGROUND selects the analyzer display background so you can modify its color from the factory-defined color list (**WHITE**, **BLACK**, **YELLOW**, **BLUE**, **SALMON**, **RED**, and **GREEN**).

WARNING selects the warning messages so you can modify the color from the factory-defined color list (**WHITE**, **BLACK**, **YELLOW**, **BLUE**, **SALMON**, **RED**, and **GREEN**).

LABELS selects softkey labels, status line, frequency labels, and title so you can modify the color from the factory-defined color list (**WHITE**, **BLACK**, **YELLOW**, **BLUE**, **SALMON**, **RED**, and **GREEN**).

MONOCHROME sets all of the analyzer display attributes to green. A highlighted box surrounds the active mode labels, and the analyzer highlights all attributes associated with the active channel.

MEAS→MEM stores the current measurement data into memory in dB/dBm format (even when you view the data in SWR format). You can also store voltage data (ADC IN) into memory.

MEAS-M→MEM stores the measurement-minus-memory (normalized trace) into memory. You can use this function only for ratio measurements.

Horizontal Display Resolution

Display Resolution

The analyzer's display resolution is dependent on the number of channels that you have displayed.

1601 data points available with one channel displayed

801 data points available with up to two channels displayed

401 data points available with up to four channels displayed

Use the **#TRACE POINTS** softkey in the system menu to change the number of trace points. If adaptive normalization is on, the cal data is linearly interpolated when you increase the number of trace points after a calibration.

The number of data points and number of channels displayed also affects the minimum sweep time.

Table 4-1. Minimum Sweep Time Versus Number of Points

Number of Points	Minimum Sweep Time (ms)			
	1 Input	2 Inputs	3 Inputs	4 Inputs
101	40	40	40	40
201	40	40	52	68
401	40	72	104	136
801	80	144	208	272
1601	160	288	N/A	N/A

Measurement Resolution

The analyzer stores memory data at the highest resolution regardless of the display resolution, scale per division, or reference level. Table 4-2 shows the measurement resolution and range for the various display modes. The display range can exceed the limits shown when detector offsets are applied.

Table 4-2. Measurement Ranges and Resolution

Display Mode	Measurement Range ¹	Measurement Resolution	Normalized
dBm	-70 to +20 dBm	0.003 dB ²	.006 dB
dB	-90 to +90 dBm	0.006 dB ²	.011 dB
SWR	1.0 to 37.0	See graph below	-
AUX	-10 to +10 V ³	0.70 mV	1.40 mV

¹ Detector offset is not included.

² 0.01 dB for display cursor.

³ -20 to +20 V for normalized AUX.

DISPLAY

The analyzer calculates SWR from dB data. SWR resolution varies with the SWR measured:

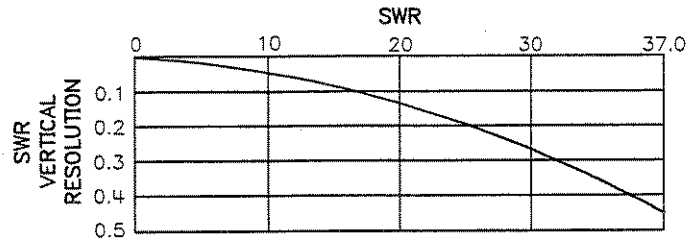

SCALE — Scale Menus

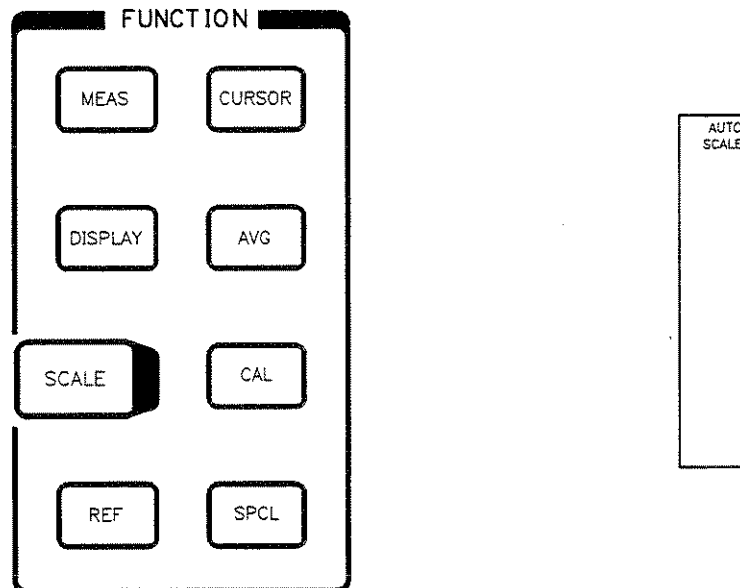

Figure 4-4. SCALE Key and Scale Menu

The **SCALE** key allows you to select the scale per division for viewing measurement data. You can change the scale factor with the knob, STEP keys, or numeric keypad. The resolution is finer when you are using the knob. Table 4-3 lists the possible choices for each display mode if you are using the step keys. If you use the keypad to enter the scale factor, you must terminate the entry with either the **dBm/dB** or **ENT** key.

AUTOSCALE adjusts the active trace scale and reference level to best fit within the graticule.

Table 4-3. Default Scale Per Division for Display Modes

Display Mode	Scales Per Division Using the Step Keys
dB/dBm	20, 10, 5, 1, 2, 0.5, 0.2, 0.1
SWR	10, 4, 2, 1, 0.4, 0.2, 0.1, 0.04, 0.02 SWR units
AUX (ADC IN)	5, 2.5, 1, 0.5, 0.25, 0.1, 0.05, 0.025V

Note

The analyzer allows you to set the scale factors for MEAS, MEM, and MEAS-MEM display modes separately. This function permits you to set the optimum scale factor for each of these display types.

REF — Reference Menus

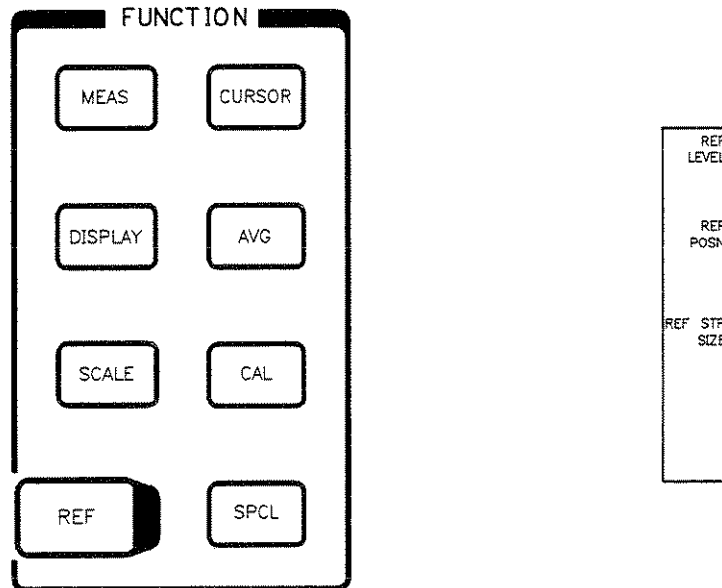

Figure 4-5. REF Key and Ref Menu

The **REF** engages the reference level function (Figure 4-5).

REF LEVEL lets you set the value of the reference level line (the horizontal line indicated by the reference position indicator on the left side of the analyzer display). Varying the value of this line and the scale per division lets you measure any data point and view the measurement data relative to the reference level line value. Use the knob, STEP keys, or numeric keypad to enter the reference level, and terminate the entry with the **dBm/dB** or **ENT** key.

REF POSN lets you set the position of the reference level line to any of the major graticules with the knob, a step key, or the numeric keypad terminated with **dBm/dB** or **GHZ**. If you use the numeric keypad to position the reference, entering **0** places the reference on the bottom graticule and entering **9** places the reference on the top graticule. The channel number and the ">" symbol to the left of the analyzer display graticule show the current position of each channel's reference level line.

REF STP SIZE sets the size of the steps used to increment or decrement the reference level value. You can set the reference step size with the numeric keypad, step keys, or the front panel knob. Terminate the entry with the **dBm/dB** or **ENT** key.

CURSOR — Cursor Menus

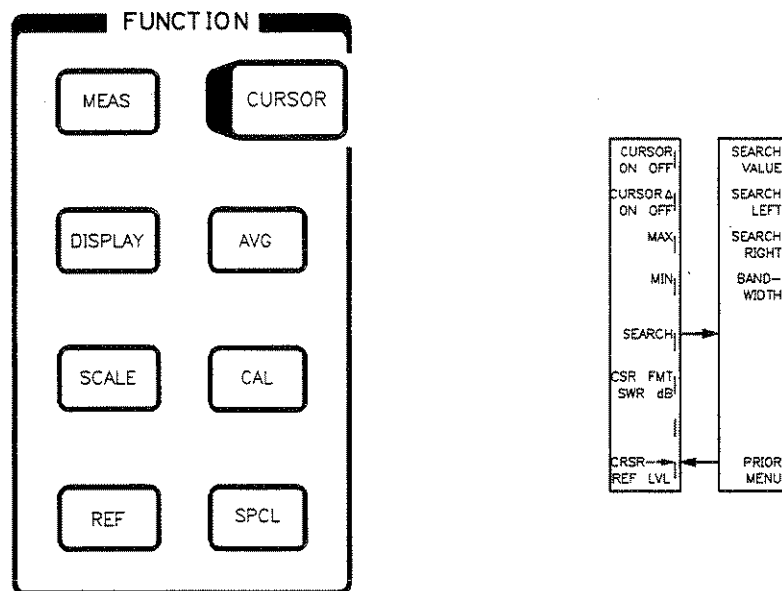

Figure 4-6. CURSOR Key and Display Menus

The CURSOR key presents the cursor menu (Figure 4-6) and engages the cursor (∇) on all channels. You can turn the front panel knob to move the cursor and quickly read the measured amplitude and frequency value of any data point. The analyzer active entry area shows the amplitude and frequency value of the data point at the active channel cursor position. The mode labels area also display the cursor values. The cursor units correspond to the measurement and display mode selected (such as dB or SWR), with the value resolved to 0.01 dB, 0.001 SWR, or 0.001 V.

Cursor Interaction with Source Markers

With a cursor activated, the analyzer displays the amplitude and frequency information of the cursor position. If you turn the cursor function off and activate a source marker, the analyzer will display the amplitude and frequency information of the marker position (assuming the source is compatible with the HP 8757 system interface).

Although both cursors and markers display amplitude and frequency information, their intended use is for different applications.

Applications for Analyzer Cursors. Cursors are particularly useful in the following situations:

- when you want to measure bandwidth
- when you want to measure one point in reference to another point
- when you only want to display ≤ 2 cursors

CURSOR

Applications for Source Markers. Markers are particularly useful in the following situations:

- when you want to sweep a range designated by two markers
- when you want to display more than two markers

Source Capabilities. Sources that are HP-IB compatible can provide the analyzer with frequency sweep information over the sytem interface. The analyzer displays the conveyed source information as start, stop, and marker frequency. If your system interface is not connected, you can set the analyzer frequency labels so the analyzer will display the correct start, stop, and marker frequencies. If you engage alternate sweep, the frequency labels area displays the marker information for both sweeps.

You can activate up to five markers on an HP 8350B sweep oscillator, or an HP 8340, 8341, or 8360 Series synthesized sweeper. An HP 83750 Series sweeper allows you to activate up to ten source markers. You activate and move the source markers from the source front panel.

Most HP 8757D compatible sources create a sweep ramp of 0 to +10 volt sweep ramp. An HP 83750 Series source creates a pulse train that consists of 1μ second pulses in both continuous and step sweep modes.

CURSOR ON OFF toggles the cursor on or off. When the cursor is on, it appears as ∇ . You must turn the cursor off to display the marker frequency and amplitude information.

CURSOR A ON OFF toggles the cursor delta function on and off. With the function on, a Δ appears at the previously set cursor position, designating a reference. The analyzer also displays another cursor that you can set to any frequency within the displayed range, using the numeric keypad or front panel knob. Then the analyzer displays the value difference between the two trace points. When you engage alternate sweep, the frequency labels area displays the cursor frequencies for both sweeps.

MAX positions the cursor to the maximum value point on the active channel trace for the current sweep. The analyzer does not continuously update the cursor position to the maximum point. After data is updated, select **MAX** again to relocate the cursor to the maximum point.

MIN positions the cursor to the minimum value point on the active channel trace.

SEARCH presents the search menu and lets you search for a specific value in dB or dBm on the active channel. Use this function with **CURSOR Δ ON** to find a power difference in dB. (You cannot use search functions with SWR or AUX modes.) When you select this softkey, the analyzer displays the search menu and the active entry area shows the previous search value. To change this value, use the knob, STEP keys, or numeric keypad, terminating the entry with the **dBm/dB** or **ENT** key. Then use the search left/right softkeys to locate the entered value.

SEARCH VALUE lets you change the search value.

Press **CURSOR**, **SEARCH**, **SEARCH VALUE**, and enter the value, for example, **4** **dB** using the numeric keypad.

SEARCH LEFT causes the cursor to move left to the first position where the search value exists. When necessary, the analyzer interpolates the point between two existing values and calculates the corresponding frequency. If the analyzer cannot find the value, the analyzer displays **WARNING: Cursor Value not found..** If the search is successful, the

analyzer holds the measurement trace as noted by the displayed message Value Found: Trace Hold. By pressing any key, you can release the trace hold.

In a normalized measurement, the search function finds the n-dB point from the 0 dB reference line. In cursor Δ mode, search values are found for the n-dB points from the Δ cursor reference.

SEARCH RIGHT works the same as **SEARCH LEFT**, except that the cursor moves to the right.

BANDWIDTH determines the trace bandwidth at a specified value down from the maximum trace value. You can set the n-dB value for the bandwidth with the STEP keys or the numeric keypad; terminate the entry with the **dBm/dB** or **ENT** key. The analyzer searches automatically for the maximum trace amplitude, then finds the n-dB down points on both sides and shows the bandwidth in the active entry area.

CSR FMT SWR DB lets you view the cursor data in SWR when displaying device return loss in dB. However, if you are displaying the format in SWR, the cursor data will also be in SWR.

CURSOR—REF LVL sets the reference level value equal to the cursor reading. The reference position does not change, the trace moves to the reference level. By using this softkey and decreasing the scale factor, you can expand the trace about the cursor for detailed viewing.

AVG

AVG — Average Menu

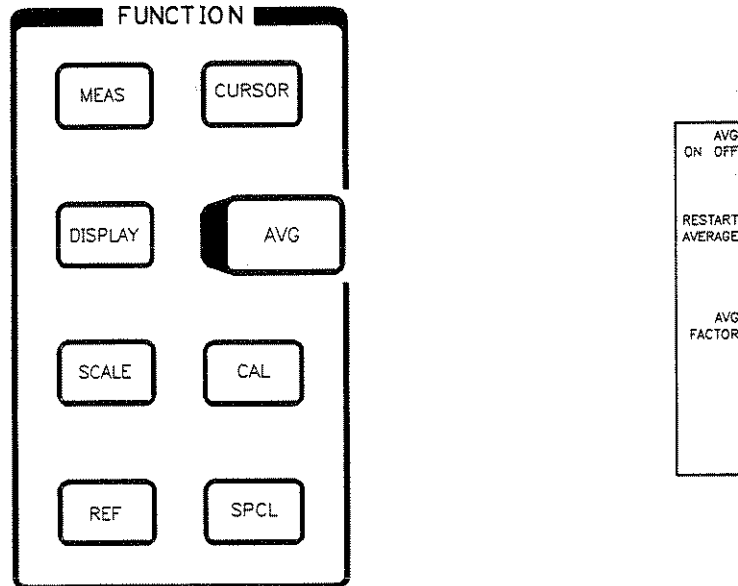

Figure 4-7. **AVG** Key and Average Menu

The **AVG** function averages a programmable number of sweeps. When you activate averaging or restart averaging, the analyzer uses an averaging factor of one on the first sweep, two on the second sweep, four on the third and fourth sweep, and increasing powers of two up to the desired averaging factor. This technique removes noise from calibration or measurement traces. The analyzer performs averaging on logarithmic data. When you engage SWR format, the analyzer performs the SWR conversion on the averaged data.

AVG ON OFF toggles the averaging function for the active channel on and off. The active entry area displays the averaging factor. The mode labels area displays the status symbol **A** for any channel with averaging turned on.

RESTART AVERAGE clears the averaged data and starts the averaging process to compute another set of averaged measurement data.

AVG FACTOR lets you select the averaging factor (shown in the active entry area) using the knob, STEP keys, or numeric keypad. Terminate the entry with the **ENT** key. At preset and power on, the analyzer defaults to an averaging factor of 8. You can set the averaging factor to 1, 2, 4, 8, 16, 32, 64, 128, or 256.

CAL — Calibration Menus

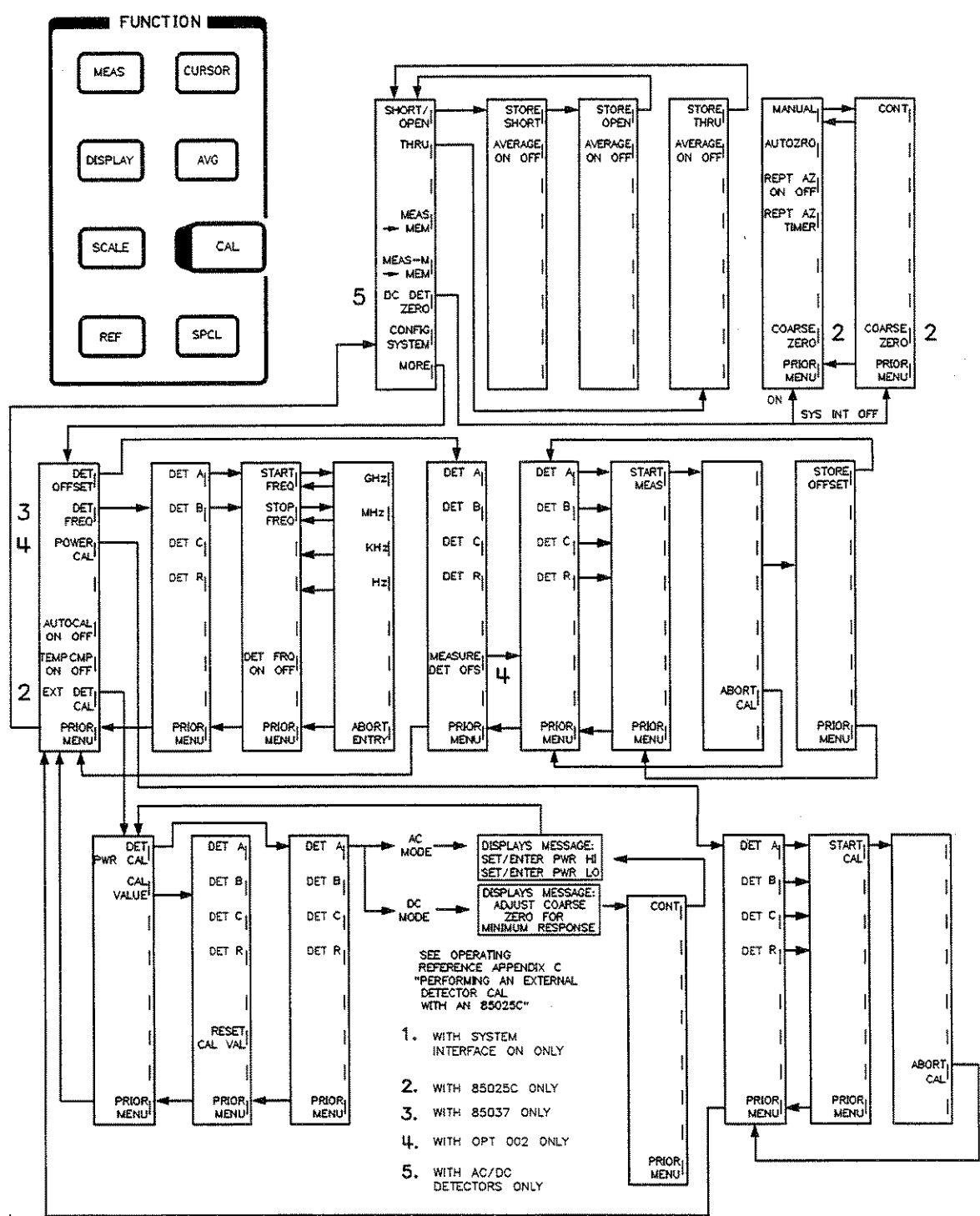

Figure 4-8. CAL Key and Calibration Menus

CAL

The **CAL** key presents the calibration menus. The softkeys in this menu allow you to do the following activities:

- perform and store calibrations
- perform detector zero calibrations
- set detector offsets
- turn on automatic internal calibration

You can perform a calibration without changing the analyzer's display mode. The analyzer measures the calibration standards, stores the data at the highest resolution, and returns the display mode you previously set.

SHORT/OPEN prompts you through a short/open calibration. The analyzer stores this calibration in memory in dB/dBm format. When you select this softkey, the analyzer displays **CONNECT SHORT ... STORE WHEN READY**, turns averaging off, and presents a second menu layer.

STORE SHORT measures the short circuit response. Connect the short to the bridge test port, and select this softkey. The analyzer displays **CONNECT OPEN ... STORE WHEN READY**, turns averaging off, and presents a third menu layer.

STORE OPEN measures the open circuit response. Connect the open circuit to the bridge test port, and select this softkey. The analyzer averages the open and short calibration data, stores it in the active channel memory, and displays the first calibration menu. The analyzer displays **SHORT/OPEN CAL SAVED IN CH1 MEM** (the indicated channel depends on the active channel).

AVERAGE ON OFF toggles averaging on and off (the same averaging function engaged when you select averaging in the averaging menu). When you press **SHORT/OPEN** or **STORE SHORT**, the analyzer turns averaging off. Therefore, if you want the calibration to be averaged, select averaging on.

The averaging factor does not change from the value you previously set in the averaging menu. If you wish to change the averaging factor, you must return to the averaging menu.

THRU prompts you to make a thru calibration. The analyzer stores this calibration in dB/dBm format. When you select this softkey, the analyzer displays **CONNECT THRU ... STORE WHEN READY**, turns averaging off, and presents a second menu layer.

STORE THRU measures the thru response. Connect the thru in place of the device under test and select this softkey. The analyzer displays:
THRU SAVED IN CH1 MEM, turns averaging off, and presents the first calibration menu.

If the analyzer is not in measurement-minus-memory mode, the analyzer displays **For Normalized Meas ... select [DISPLAY] [MEAS-MEM]**. Press these keys to normalize the measurement.

AVERAGE ON OFF toggles averaging on and off (the same averaging function engaged when you select averaging in the averaging menu). When you press **THRU** or **STORE THRU**, the analyzer turns averaging off. Therefore, if you want the stored calibration to be averaged, select averaging on.

The averaging factor does not change from the last value set in the averaging menu. If you wish to change the averaging factor, you must return to the averaging menu.

MEAS→MEM stores the current measured data into memory in dB/dBm format (even if you view the data in SWR format).

MEAS-M→MEM stores the measurement-minus-memory (normalized trace) into memory. You can use this function only for ratio measurements.

DC DET ZERO allows you to zero a DC detector, eliminating small DC voltages present in the detector, and establishing the noise floor with no RF signal applied. If your source is connected over a system interface, pressing **DC DET ZERO** presents another menu.

Otherwise, the analyzer presents the **CONT** key.

Remember Periodic zeroing is recommended for DC mode measurements. Zeroing of the detector is most important for lower level measurements.



This softkey appears in the calibration menu only when you connect an AC/DC detector or bridge to a detector input.

Zero a DC detector when you first connect it to the analyzer, *before* calibration, and whenever significant temperature changes occur.

MANUAL lets you manually remove the RF signal from the detectors. Use this method of zeroing when a small RF signal is present in the device under test (such as amplifiers, mixers, and oscillators).

Note Before pressing **CONT**, disconnect your DC detector from any RF signal, then select the manual method of zeroing.



CONT nulls any signal present at the detector input. The previous menu returns.

COARSE ZERO appears in this menu only if you connect an HP 85025C detector adapter to the analyzer. See Appendix C “Performing an External Calibration” in this manual, or refer to the HP 85025C detector adapter manual for instructions on this procedure. (This procedure, written for an HP 8757A, applies also to the HP 8757D.)

AUTOZERO turns off the RF signal from the source and automatically performs the DC detector zero. Use this method of zeroing in the following situations:

- when your source is connected to the analyzer through the 8757 system interface bus
- when your test device is NOT an active device; that is, an amplifier, mixer, or oscillator)

You can perform an autozero at any time, even with the repeat autozero function engaged. This softkey appears in this menu only if you connect a compatible source to the analyzer through the 8757 system interface.

REPT AZ ON OFF toggles a periodic autozero on and off. The analyzer is factory-set to an interval of 5 minutes.

CAL

REPT AZ TIMER lets you change the interval between autozero repeats. Use the numeric keypad to set intervals from 1 to 60 minutes (terminate the entry with the **ENT** key). The interval does not change at preset or power on.

COARSE ZERO allows you to adjust the coarse zero for a minimum signal on the analyzer. See Appendix C "Performing an External Calibration" in this manual, or refer to the HP 85025C detector adapter manual for instructions on this procedure. (This procedure, written for an HP 8757A, applies also to the HP 8757D.)

This softkey appears in this menu only if you connect an HP 85025C detector adapter to the analyzer.

CONFIG SYSTEM forces the computation on the internal calibration tables for all detector inputs shown on the analyzer display. See "Self-Calibration" in this section for more information.

MORE Presents another menu that continues the calibration menu.

DET OFFSET lets you set an offset value in dB for each detector. For example, the difference between the power reading of an analyzer input and the power meter reading, or the value of an attenuator used with a detector.

DET A, **DET B**, **DET C**, and **DET R** let you select the detector to set an offset value. The active entry area displays the current offset value for that detector. Use the step keys, knob, or numeric keypad to change the offset, and terminate the entry with the **dBm/dB** or **ENT** key. The allowable range of entry values is +60 to -60 dB. The analyzer correctly displays the data in dBm, including the offset for absolute power measurements, or dB for ratio measurements.

A detector offset, valid during both calibration and measurement, remains in effect until you change it. An offset affects the detector *input*. Therefore, the offset applies to any measurement made on that input regardless of which channel selects the measurement. When you press **PRESET**, the analyzer resets all detector offset values to zero. But, if you cycle the instrument power, the detector offset values are not affected. Offsets are stored in the SAVE/RECALL registers.

MEASURE DET OFS appears when option 002 has been installed in your analyzer. This key allows you to measure a detector offset using the 50 MHz power calibrator. The offset may be measured at any level from +20 dBm to -50 dBm. This offset may then be stored as a detector offset, which is applied during all measurements made with this detector.

A message appears on the analyzer :

```
SELECT DETECTOR FOR DET OFFSET MEASUREMENT
```

```
A:AC\DC OFS B:AC\DC R:AC\DC
```

This message shows that you can select an input for measuring an offset for that detector. The message displays that input A has an offset entered for it, and that B and C do not. Also, that AC/DC type detectors (the 85025 or 85037 Series detectors) are connected to inputs A, B, and R.

DET A, **DET B**, **DET C**, **DET R** lets you select the detector input for the offset measurement. Connect the detector and attenuator (if used) between the detector input and the calibrator.

START MEAS starts the detector offset measurement and displays the results. You may set the test power for the detector offset when the **START MEAS** menu is displayed. The calibrator power level used in the measurement is displayed as:

CALIBRATOR POWER

+0 dBm

It is recommended that a calibrator power level be set near the power at which the detector is being used.

The analyzer performs the measurement in the currently selected detection mode, AC or DC.

If you had a 6 dB attenuator connected to the detector input, you would want to measure the actual attenuation. The result display might read:

Det Offset=6.230 dB

Calibrator Pwr= 0 dBm Measured Pwr= -6.230 dBm

This means that the calibrator applied 0 dBm to the detector/attenuator and the HP 8757D measured this power as -6.230 dBm. The absolute power measured depends on the pad attenuation and factors such as temperature drift in the detector, detector RF connector wear, and inherent accuracy limitations in the detector.

If an error message is displayed during this process, refer to “In Case of Difficulty” in the Error Messages section.

ABORT CAL aborts the measurement just started.

STORE OFFSET stores the measured detector offset that will be used later to remove this offset error from measurements.

Note



You may want to connect an attenuator to the input of the detector when you are making measurements on a high power amplifier. For example, to reduce the RF power level below the detector maximum operating power level, or to reduce the power applied to the detector so harmonics in the test signal cause less power error in the measurement.

The **DET FREQ** softkey appears when you connect an HP 85037A/B detector to the analyzer. An HP 85037A/B detector assembly includes an EEPROM that contains correction constants for that particular detector operation over a range of frequencies. The correction constants provide the analyzer with an accurate detector frequency response. By pressing **DET FREQ**, you can set the start and stop frequencies to apply the detector frequency response correction for the particular measurement range.

This function could be helpful in a mixer measurement where the frequency you want the detector to measure is different from the source frequency. Refer to “Appendix D Mixer Measurements” for examples of mixer measurements.

Note

The frequency range you set after pressing **DET FREQ** affects both sweeps when the analyzer is in the alternate sweep mode. If you set the detector frequencies with channel 1 or 3 active, then the frequencies apply when channel 1 and 3 are swept. Likewise, if you set the detector frequencies with channel 2 or 4 active, the frequencies apply when channel 2 and 4 are swept.

However, you can set unique detector frequency sweep values for different measurement channels. For example:

Start = 1GHz, Stop = 11 GHz for the sweep on channels 1 and 3

Start = 3GHz, Stop = 13 GHz for the sweep on channels 2 and 4

DET A, **DET B**, **DET C**, **DET R** lets you select the detector for the entry of start and stop frequencies.

START FREQ and **STOP FREQ** allow the start and stop frequencies to be entered.

DET FREQ ON/OFF *must* be turned on for the start and stop frequencies to be activated, otherwise the analyzer will use the sweeper's start/stop frequencies.

The analyzer can display the current detector frequency settings if you enter the **CAL**, **MORE DET FREQ**, **DET A** menus (assuming that you selected detector A).

POWER CAL presents the power calibration menu. Connect the detector to be calibrated to **POWER CAL OUT**.

DET A, **DET B**, **DET C**, **DET R** lets you select the detector for the power cal.

START CAL starts the calibration. As the calibration proceeds, the analyzer displays the power level being measured. When the calibration is complete, the analyzer displays the measured range for each detector input.

ABORT CAL This key allows the user to prematurely stop a power calibration once it has been started. For example, when you started the calibration before connecting the detector.

By disconnecting a detector from the HP 8757D's input, you remove the calibration. When you reconnect the detector to the input, the analyzer uses the correction constants stored in the detector.

Note

To obtain the best accuracy, and to meet the "corrected" dynamic accuracy specifications, each detector must be characterized on the HP 8757D input where it will be used. The characterization routine simultaneously corrects both AC *and* DC measurements. This routine is also useful as an operator's check to ensure the detector is operating correctly. Only the HP 8757D with an option 002 power calibrator has this capability.

While only specified for the HP 85037 precision detector, the power calibrator also functions with and typically improves the accuracy of the HP 85025, 11664 detectors, HP 85025C external detector, and the HP 85027 bridge. This process improves the 50 MHz dynamic accuracy to the same accuracy as an HP 85037 specification.

AUTOCAL ON OFF gives you control over the automatic regeneration of the internal calibration tables for the detector inputs. Selecting this softkey toggles autocalibration on and off. See “Self-Calibration” for more details.

TEMPCMP ON OFF gives you control over the analyzer’s continuous temperature compensation. Selecting this softkey toggles temperature compensation on and off. See “Self-Calibration” for more details.

EXT DET CAL appears only if you connect an HP 85025C detector adapter to the analyzer. Use this function to calibrate the amplitude response for a Schottky diode detector.

DET PWR CAL activates a calibration sequence that consists of providing the analyzer with two known power levels. Once you perform a calibration with a detector, the analyzer retains the calibration.

DET A, **DET B**, **DET C**, **DET R** lets you select the input for the connected detectors.

CAL VALUE allows you to enter an HP 85025C detector calibration value on any analyzer input. See appendix C “Performing an External Detector Calibration” or the HP 85025C manual for instructions on this procedure (although written for an HP 8757A, it applies also to an HP 8757D).

DET A, **DET B**, **DET C**, **DET R** lets you select the detector.

RESET CAL VALUE allows you to reset the cal value to factory-set default value.

Self-Calibration

The calibration menu softkeys **CONFIG SYSTEM**, **AUTOCAL ON OFF**, and **TEMPCMP ON OFF** relate to the analyzer’s internal calibration. With both autocalibration and temperature compensation on, the analyzer performs all internal calibration automatically, making it transparent to the user. The analyzer automatically maintains absolute and dynamic power accuracy for each detector input using two independent digital correction processes:

1. autocalibration — a regeneration of the internal calibration tables whenever:
 - you change the accessory configuration
 - a significant change in temperature occurs (approximately 5°C)
2. temperature compensation — a continuous compensation for small changes in temperature

You can control both of these correction processes in the second calibration menu. At preset or power-on, both autocalibration and temperature compensation are on, and the analyzer performs all internal calibrations automatically.

Autocalibration

When you turn autocalibration on by selecting **AUTOCAL ON**, the analyzer automatically updates the internal calibration tables. Use autocalibration for most applications. The analyzer may update its internal calibrations tables under any of the following conditions:

With autocalibration on *or* off:

- at instrument preset, power-on, or recall instrument state
- **CONFIG SYSTEM** softkey selected

Only with autocalibration on:

- detector or bridge configuration changed
- large temperature change
- at a fixed 5-minute interval

To regenerate the calibration tables, the analyzer determines the following for each detector input:

- detector or bridge type (AC only or AC/DC)
- detector or bridge power versus voltage characteristics
- temperature of the detector (AC/DC accessories only) and the log amplifier

Using these readings, the analyzer automatically computes the internal calibration tables and the analyzer displays **CONFIG SYSTEM COMPLETED**. Depending on the configuration, the table regeneration process can take a few seconds.

In a thermally stable environment (temperature drift less than 5°C), thermal drift in the log amplifiers is minimal. The detectors, however, may be exposed to significant changes in temperature. Autocalibration automatically compensates for significant temperature changes.

Temperature Compensation

When you turn temperature compensation on **TEMPCMP ON**, the analyzer performs continuous temperature compensation to the data. This corrects the measurement data for small drifts in temperature without the need to recompute the calibration tables.

Always use temperature compensation when you make measurements (this function turns on at preset and power-on). Turn off temperature compensation *only* when diagnosing a possible problem with the analyzer or its detectors.

SPCL — Special Menus

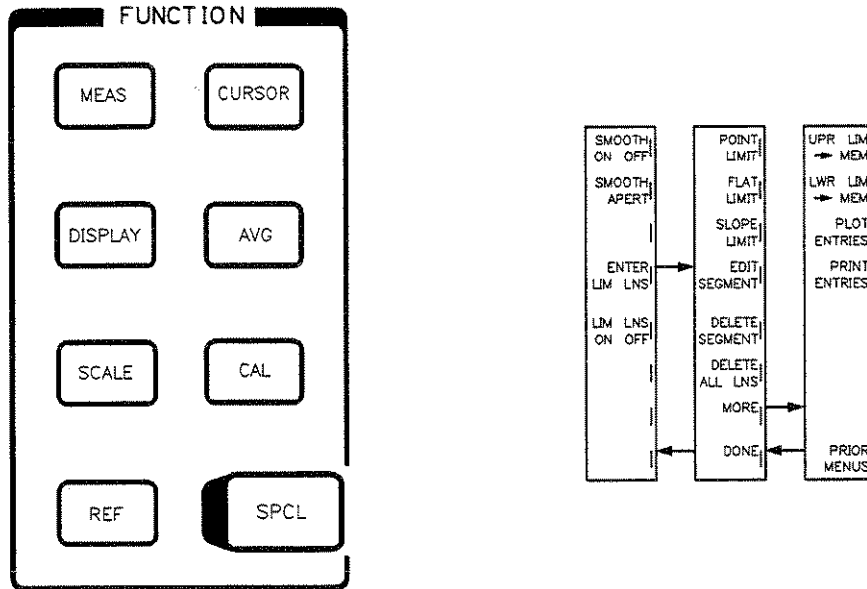

Figure 4-9. SPCL Key and Special Menus

SMOOTH ON OFF toggles the smoothing function (video filtering) on and off. Smoothing calculates a moving average of the active channel data. The aperture of the moving average is a percent of the sweep span, not greater than 20%.

Smoothing differs from averaging in that smoothing computes each data point based on one sweep, on the average of data points on both sides of that data point in the current sweep, while averaging computes each data point based on the average value of each point during several sweeps. The mode labels status symbols area displays an “S” for any channel with smoothing activated. Preset turns smoothing off for all channels.

SMOOTH APERT lets you change the value of the smoothing aperture. The aperture defaults to 5% at preset. Use the knob, STEP keys, or numeric keypad to change the smoothing aperture value. Enter any value from 0.1 through 20%.

ENTER LIM LNS presents the first of two limit lines menus. Using these softkeys, you can define limit lines for channel 1 and for channel 2. The limit lines consist of upper and lower limits for a frequency or a band of frequencies. You can also choose just the upper or the lower limit. After you activate the limit lines, the measurement data is compared to the displayed limit lines. The analyzer displays FAIL below the mode labels area for an out-of-limit condition. You can choose from three types of limit lines:

- point
- flat
- slope

SPCL

A limit line can contain up to 12 segments; each segment can be any one of the three types. Segments entered from the front panel are numbered sequentially; those entered through HP-IB can be entered randomly. The analyzer prompts you for frequency, upper, and lower limits. Use the numeric keypad to enter the frequency, terminating the entry with the appropriate softkey: **x1**, **Hz**, **KHz**, **MHz**, **GHz**. Use the numeric keypad to enter the upper and lower limits, terminating the entry with the **dBm/dB** or **ENT** key. If you do not want either an upper or lower limit, press **dBm/dB** or **ENT** at the prompt. You can store limit lines *only* in save/recall registers 1 through 4. You can enter limits in dB, dBm, V (in AUX mode), or SWR, depending on the display format. In SWR mode, however, you cannot save the limits in trace memory.

POINT LIMIT lets you define a limit for a single frequency point.

FLAT LIMIT lets you define a flat limit (a constant value between two frequency points).

SLOPE LIMIT lets you define a sloped limit between two frequency points (linear with frequency).

EDIT SEGMENT lets you redefine an existing limit line segment. When you select this softkey, the analyzer prompts you for the number of the segment you wish to change. Use the numeric keypad to enter the segment number, then press **ENT**. The analyzer deletes the entire segment. Re-enter the segment. First choose the limit type from the softkeys. The analyzer then prompts you to enter frequencies and limit values.

DELETE SEGMENT lets you delete an entire limit line segment. The analyzer prompts you for the segment number to delete. Use the numeric keypad to enter the segment number and terminate the entry with the **ENT** key.

DELETE ALL LNS lets you delete all existing limit lines for that channel.

UPR LIM—MEM places the upper limit line into memory.

LWR LIM—MEM places the lower limit line into memory.

When you put either the upper or lower limit line into memory, the active channel memory is initialized with a 0 dB (or 0 dBm) reference level. The limits are then updated in memory in the order you entered the segments. (For overlapping limits, the last entry overwrites any overlap of the previous entry, and points with no limit data entered as 0 dB or 0 dBm.) You cannot use the limit-line-to-memory functions with SWR display mode.

PLOT ENTRIES sends the limit line frequency and amplitude values to the plotter (in tabular format).

PRINT ENTRIES sends the limit line frequency and amplitude values to the printer (in tabular form).

DONE terminates limit line data entry for the active channel. It also returns the special functions menu.

LIM LINS ON OFF toggles the limit lines on and off for the active channel. When you turn limit lines on, each limit line segment becomes visible on the analyzer as you enter it. You can turn limit lines on, even without entering limit lines. In this case, the analyzer displays **PASS** for any measurement data.

INSTRUMENT STATE

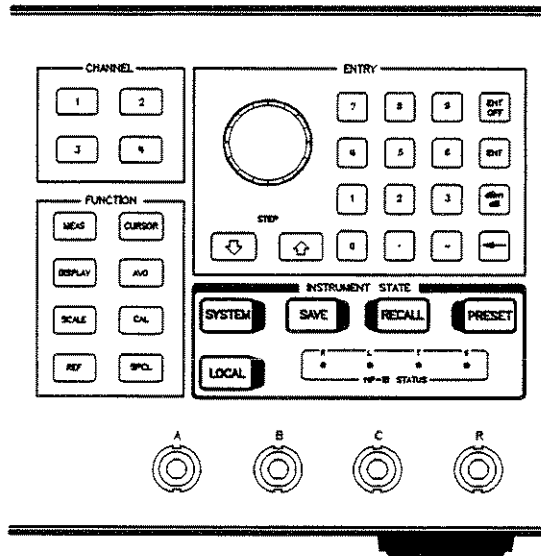

Figure 5-1. Instrument State Keys

Use the INSTRUMENT STATE keys (Figure 5-1) to control system functions that are not channel-specific but apply to the entire instrument state.

SYSTEM — System Menus

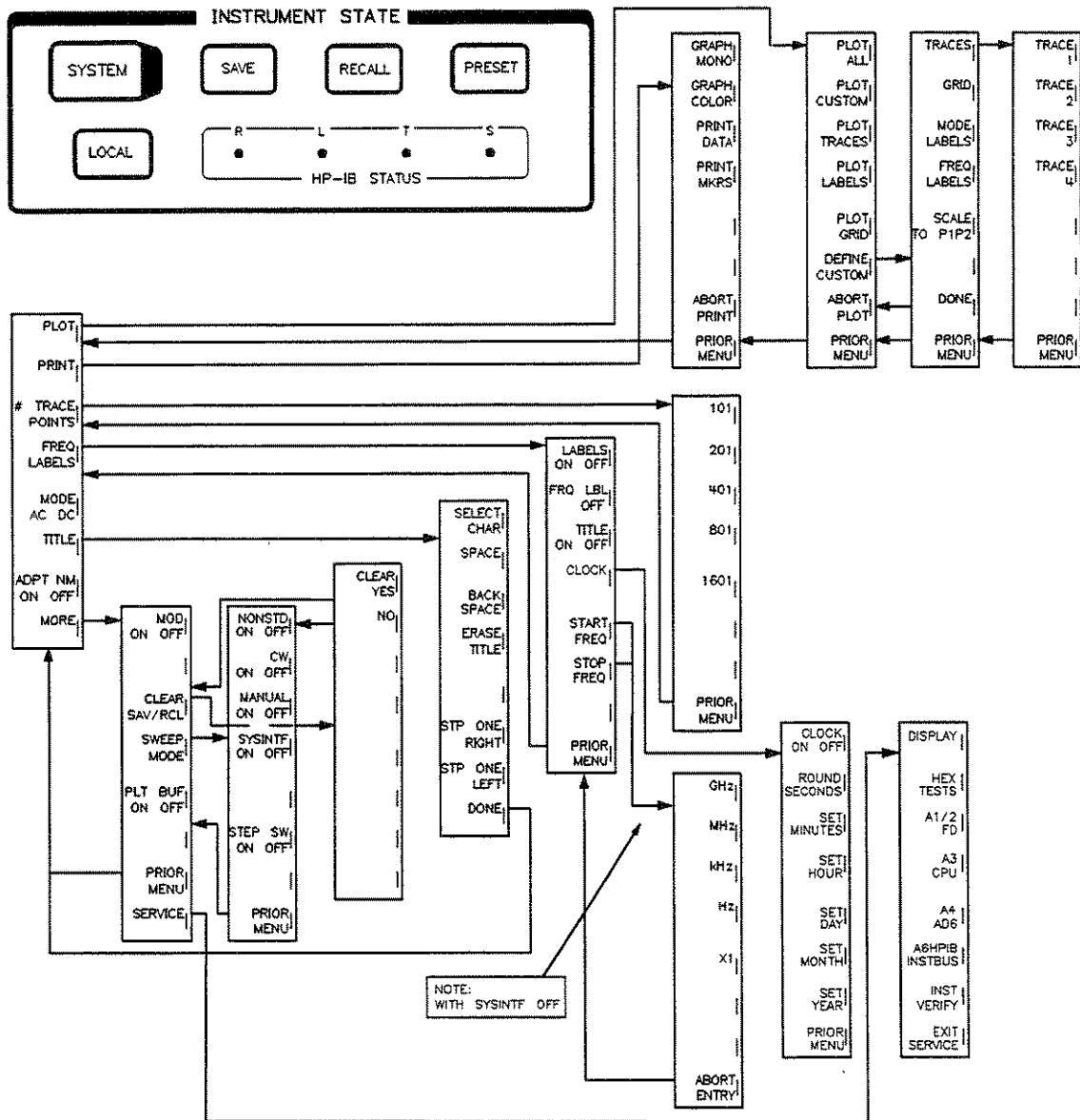

Figure 5-2. SYSTEM Key and System Menus

The SYSTEM key presents the system menus, providing a variety of softkey functions that apply to the entire instrument state (such as plotting, printing, AC and DC detection mode, number of trace points, clock, and service).

PLOT presents the first of four plot menus that allow you to custom-define and initiate plots on a plotter on the HP 8757 system interface.

When you select a plot softkey, the analyzer freezes the displayed measurement and sends the data through a buffer.

Once the data is at the buffer, the analyzer can continue making measurements while the plotter makes a hardcopy.

The analyzer expects to find the plotter at HP-IB address 5, unless you set a different address (see **LOCAL**). If you set the plotter address incorrectly, or do not connect it to the 8757 SYSTEM INTERFACE, the analyzer displays PLOTTER NOT AVAIL. Correct the problem and press **PLOT** again to start generating the hardcopy.

If you do not load any paper, the analyzer displays PLOTTER NOT READY. Correct the problem and press **PLOT** again to start generating the hardcopy.

PLOT ALL causes the plotter to draw the grid, labels, trace data, cursor, markers, title, date, time, and (when turned on) limit lines and pass/fail indicators. Any message displayed in the active entry area also plots. (Press **ENT OFF** before plotting if you do not want the message to appear.) Plots do not include status line information.

PLOT CUSTOM causes the plotter to draw a plot using only the attributes specified with the **DEFINE CUSTOM** softkey in this menu.

PLOT TRACES draws the trace data for all the channels turned on. The traces include cursors, cursor deltas, and markers. And if the functions are turned on, the traces also include limit lines, pass/fail indicators, and a date/time stamp.

PLOT LABELS draws the mode labels, reference line position labels, and frequency labels (when turned on).

PLOT GRID draws the horizontal and vertical graticule lines.

DEFINE CUSTOM lets you specify which plot attribute or combination of attributes to include in a custom-defined plot format. The format you define is reflected in the hardcopy when you press **PLOT CUSTOM**. The analyzer highlights the softkey labels for the attributes you select to plot.

TRACES lets you specify the trace or traces that the plotter draws on the hardcopy (traces 1-4). Each trace softkey toggles on and off. You can only plot traces of channels that are turned on (**TRACE 1**, **TRACE 2**, **TRACE 3**, **TRACE 4**).

GRID includes the horizontal and vertical graticule lines in the custom plot format.

MODE LABELS includes the mode labels in the custom plot format.

FREQ LABELS includes the frequency label information in the custom plot format (unless you turn them off by pressing **LABELS OFF** or **FRQ LBL OFF**). The label information includes the sweep frequencies and cursor frequency.

SCALE TO P1P2 expands the plot to place the lower left corner of the grid at the plotter's P1 position, and the upper right corner of the grid at the plotter's P2 position.

SYSTEM

DONE terminates the custom plot format definition and displays the prior plot menu.

ABORT PLOT terminates the plotting of a hardcopy. The plotting does not stop immediately; it stops after the buffer empties.

PRINT presents menus that allow you to select printing options.

When you select a print softkey, the analyzer freezes the displayed measurement and sends the data through a buffer. Once the data is at the buffer, the analyzer can continue making measurements while the printer generates a hardcopy.

The analyzer expects to find the printer at HP-IB address 5, unless you set a different address (see **LOCAL**). If you set the address of the printer incorrectly, or do not connect it to the 8757 SYSTEM INTERFACE, the analyzer displays **PRINTER NOT AVAIL**. Correct the problem and then select the print softkey again to begin printing.

If you connect the printer correctly but do not load any paper the analyzer displays **PRINTER NOT READY**. Correct the problem and then select the print softkey again to begin printing.

GRAPH MONO causes the monochrome printer to draw the grid, labels, trace data, cursors, markers, date, time, and title. Messages in the active entry area and most softkeys are not included.

GRAPH COLOR causes the color (HP PaintJet) printer to draw the grid, labels, trace data, cursors, markers, date, time, and title. Messages in the active entry area are not included. The printer prints with a default set of colors that approximate the analyzer default colors with white and black reversed. You cannot change the fixed printer default colors.

Both mono and color prints include limit lines and pass/fail indicators.

Graphics written to the analyzer display through the HP-IB are not drawn by the printer. You can access the printer with passthrough commands (described in "Remote Operation").

PRINT DATA causes the printer to list all data in tabular form (Table 5-1).

Table 5-1. Example Printout for **PRINT DATA**

No.	Frequency (Hz)	Chan. 1 (dBm)	Chan. 2 (dBm)
0	1E+07	-3.391	-57.017
1	2.4975E+07	-3.187	-55.555
2	3.995E+07	-3.127	-53.998
3	5.492E+07	-3.141	-59.741
4	6.99E+07	-3.176	-56.984
5	8.487501E+07	-3.215	-54.775
6	9.985003E+07	-3.248	-59.370
7	1.14825E+08	-3.248	-54.759
8	1.298E+08	-3.196	-55.099
9	1.44775E+08	-3.122	-57.909
10	1.5975E+08	-3.058	-58.939
11	1.74725E+08	-2.998	-54.855
12	1.897E+08	-2.970	-53.866
13	1.046751E+08	-3.006	-55.844
14	2.1965E+08	-3.039	-59.211

PRINT MKRS signals the printer to generate a listing of the frequency and amplitude values of the source markers that you have activated. The cursor amplitude value and frequency also print if you turn the cursor on (see Table 5-2).

Table 5-2. Example Printout for PRINT MKRS

Markers			
No.	Frequency (Hz)	Chan. 1 (dBm)	Chan. 2 (dBm)
1	2.930125E+09	-12.122	+2.570
2	3.798676E+09	-12.207	+1.894
3	2.211325E+09	-14.600	+2.886
Cursors			
1	1.971725E+09	-14.548	+2.701
d	2.06655E+09	+4.370	+ .514

If you are using the alternate sweep mode, the printouts include the channel pair with the active channel (channels 1 and 3 or channels 2 and 4). To print the other pair, activate one of the channels in that pair and print again.

ABORT PRINT terminates the printing of a hardcopy. The printing does not stop immediately; it stops after the buffer empties.

TRACE POINTS lets you choose the number of data points that the analyzer uses to process and display the measurement. If you select fewer points, the analyzer will have lower resolution, but you can set faster sweep times. You can select a maximum of points (for each trace) depending on the number of traces you have displayed on the analyzer:

- 401 trace points for up to four traces displayed
- 801 trace points for up to two traces displayed
- 1601 trace points for only one trace displayed

The number of points you selected does not change at power on. However, at instrument preset, the analyzer defaults to 401 points.

FREQ LABELS allows you to access the screen labels, frequency labels, clock, and title functions.

LABELS ON OFF toggles the mode labels, the frequency labels, and the analyzer display status line on and off.

If you activate any limit lines, the pass/fail indicator is not blanked until you disable the limit lines.

FRQ LBL OFF turns off the frequency labels, and blanks the source frequency readout. If you press this softkey, the frequency labels information will not get plotted or printed. You can restore the frequency labels by presetting the analyzer, but this also resets the frequency information to preset conditions.

SYSTEM

Even if you have the frequency labels off when you save or store an instrument state, the complete source instrument state information is included. However, when you recall the instrument state, the frequency labels are off, reflecting the state that you have saved. See **CLEAR SAV/RCL** for additional information.

HP-IB programming commands also let you turn the frequency labels off so you can operate the analyzer in the secure frequency mode. See "Secure Frequency Mode" in any of the remote operation documents.

TITLE ON OFF toggles the titles on and off without erasing the title.

CLOCK allows you to set the time and date so they appear on measurement prints and plots.

CLOCK ON OFF toggles the time and date function on and off. If the clock function is on, the date and time will be displayed on the analyzer and will also appear on any measurement prints or plots.

ROUND SECONDS sets the seconds of the analyzer clock to zero. The function also rounds the seconds to the nearest minute.

SET MINUTES allows you to set the minutes for the analyzer clock. Your entry must be terminated by pressing **ENT**.

SET HOUR allows you to set the hour for the analyzer clock. Your entry must be terminated by pressing **ENT**.

SET DAY allows you to set the day of the month for the analyzer clock. Your entry must be terminated by pressing **ENT**.

SET MONTH allows you to set the month of the year for the analyzer clock. Your entry must be terminated by pressing **ENT**.

SET YEAR allows you to set the year for the analyzer clock. Your entry must be terminated by pressing **ENT**.

START FREQ lets you specify the start frequency value that will appear at the left graticule. You can use this function only with the system interface off or without a source HP-IB connection. After you select **START FREQ**, enter the start frequency with the numeric keypad and terminate the entry with the appropriate units softkey (such as **GHZ** or **MHZ**).

STOP FREQ lets you specify the stop frequency value that will appear at the right graticule. You can use this function only with the system interface off or without a source HP-IB connection. Engage this function the same way as **START FREQ**.

Note



The frequency labels are useful if you are making a swept measurement without an HP-IB sweeper, or with the system interface off.

MODE AC DC toggles between AC and DC detection modes. If you connect a source to the system interface, the analyzer automatically controls the source modulation (normally on for AC and off for DC).

TITLE allows you to define a title that can appear on the analyzer display and on a hardcopy. You select each character of the title from the active entry area. The characters consist of the letters of the alphabet, the digits 0 through 9, a decimal point, and the mathematical symbols $() + - / . = :$.

SELECT CHAR enters a character you selected to be included in the title. Turn the knob or repeatedly press the **STP ONE RIGHT** or **STP ONE LEFT** softkey until the arrow points to the character you want. Press **SELECT CHAR** and the character appears in the title.

SPACE inserts a blank space next to the last character you entered for the title.

BACK SPACE deletes the last character you entered for the title.

ERASE TITLE deletes the entire title you just entered.

STP ONE RIGHT moves the arrow pointer to the next character on the right.

STP ONE LEFT moves the arrow pointer to the next character on the left.

DONE terminates the title entry and displays the system menu.

ADPT NM ON OFF toggles adaptive normalization on and off. Adaptive normalization interpolates the calibration data stored in the analyzer memory when you reduce the frequency span or change the number of points. This feature allows you to display a portion of the calibrated frequency range without recalibrating. The resolution of the narrower range does not change as you expand the trace. Do not use adaptive normalization if the device response varies greatly with frequency.

An asterisk appears in the status symbols area for any channel with adaptive normalization engaged. If you expand the frequency range beyond the calibrated range, the analyzer extrapolates the calibration data outside that original frequency span as a straight line. In this case, a U appears in the status symbols area.

MORE displays the continued portion of the system menu.

MOD ON OFF toggles the analyzer rear panel modulation output on and off. You can use this softkey to override the analyzer's automatic switching of the modulation on in AC detection mode and off in the DC detection mode.

CLEAR SAV/RCL clears all of the save/recall registers and presets both the analyzer and a connected compatible source. When you press this softkey, the analyzer displays IF YOU WANT TO CLEAR ALL REGISTERS, PRESS YES, and displays a menu where you can choose to clear the storage registers.

CLEAR YES clears all the analyzer save/recall registers and returns the channel menu to the instrument preset state.

NO displays the prior system menu with all of the save/recall registers contents intact.

Note

If you are working in a high-security environment, you can configure the analyzer to clear all save/recall registers each time you switch off the instrument power. You can enable this function as follows:

1. Remove the battery (A3BT1) from the A3 CPU board. This prevents storage of any register data. The internal self test now indicates a battery failure at power up.
2. Install a wire jumper (A3W2) on the A3 CPU board, just below U2. This jumper signals the CPU to skip the battery self-test so the analyzer can resume normal operation. The analyzer briefly displays a warning message at each power cycle: **SAVE/RECALL registers defaulted.**

By removing the battery, you only affect the save/recall registers, not the analyzer's internal calibration.

SWEEP MODE presents a menu that allows you to specify the type of sweep supplied by a source that is not compatible with the HP 8757 system interface.

NONSTD ON OFF enables the analyzer to track a sweep ramp other than the typical 0 to 10 volt ramp. The nonstandard sweep should be within the 0 to 10 volt range or you must modify the A4 ADC assembly (see the service manual for instructions). See Product Note 8757-5 for a more detailed description of this mode.

To use the nonstandard sweep mode, disconnect the POS Z BLANK, the STOP SWEEP, and the 8757 SYSTEM INTERFACE connections to the source. You must have the SWEEP IN connected between the analyzer and source. The number of trace points you selected still applies in the nonstandard sweep mode.

CW ON OFF allows you to use a source that is incompatible with the HP 8757 system interface. With **CW ON**, the analyzer continuously updates the display when you set the source to CW. If you use a source that is compatible with the HP 8757 system interface, the analyzer selects this function automatically when you set the source to a CW mode.

MANUAL ON OFF toggles the manual sweep control on and off. With the analyzer manual function on, you can manually sweep the frequency range from the source. This function also allows you to use a manual sweep input signal from a source that is not compatible with the HP 8757 system interface.

SYSINTF ON OFF toggles the analyzer's control of the HP 8757 system interface on and off. With the analyzer's control OFF, another instrument on the HP 8757 system interface can control the instruments connected to the interface.

Instrument preset does not change the setting of this function. When the analyzer's control is off, the analyzer status line displays **SYS INTF OFF**.

STEP SW ON OFF (available only with an HP 8340, 8360, or 83750 Series sources) toggles the step-sweep mode on and off. If you are using the step-sweep mode you must connect the source to the HP 8757 system interface.

PLT BUF ON OFF turns the plotter buffer on and off. If you select a plot softkey with the buffer on, the analyzer will continue measuring a device response while the plotter makes a hardcopy. However, not *all* active functions are available during a plot. If the buffer is off, the analyzer disables all active functions until a plot is finished. The analyzer is sent from the factory with the plotting buffer on. If you want the fastest plotting process, set the buffer off.

SERVICE displays the service menu, which allows you choose from a series of automated tests that check various analyzer functional blocks.

DISPLAY allows you to check self-tests, verify the A14 circuitry, and adjust various display intensity levels.

HEX TESTS checks many different parts of the instrument with read/write and rotate tests. The CPU is instructed to access a user specified memory or I/O address and read or write data from or to that address, or write a rotating 1 data pattern.

These tests use the hexadecimal (hex) numbering system: Hex digits from 0 to 9 and A to F represent decimal numbers from 0 to 15. Each hex digit represents four binary digits or bits. An address is specified by six hex digits, while a data word is specified by four hex digits.

A1/2 FP presents a menu of tests the check the front panel knob, keys, and annunciators. In some cases, you can prompt the analyzer to force a diagnostic test even if the front panel is not working.

A3 CPU helps troubleshoot the A3 CPU assembly by accessing tests that check the RAM, programmable timer, EEROM, and the read function.

A4 ADC helps to troubleshoot the A4 analog-to-digital converter assembly by accessing tests that check the analog to digital signal converters, digital to analog signal converters, detector control circuitry, and sweep operation.

HP-IB TESTS helps to troubleshoot the A6 HP-IB assembly by checking HP-IB listen and talk modes.

INST VERIFY performs nine major instrument self-checks.

EXIT SERVICE returns to normal operation by initiating an instrument preset.

LOCAL

LOCAL — Local Menu

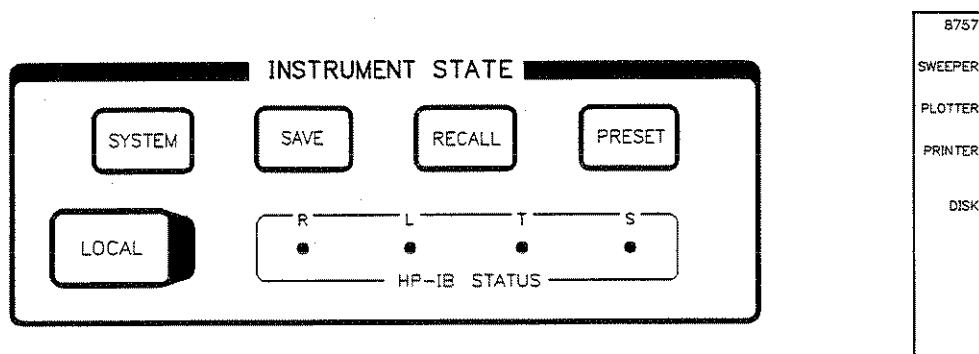

Figure 5-3. LOCAL Key and Local Menu

The LOCAL key returns the analyzer to local operation from the remote operation state unless a LOCAL LOCKOUT command has been received over HP-IB. The local menu lets you set HP-IB addresses for the analyzer and other instruments connected to the HP 8757 system interface. Table 5-3 lists the default addresses for these instruments.

Table 5-3. HP-IB Default Addresses

Instrument	HP-IB Address
8757	16
Sweeper	19
Plotter	05
Printer	01
Disk Drive	00

Changing a Default Address

Do not set two instruments to the same HP-IB address. To change a default address:

1. Select the softkey for the instrument you wish to change. The analyzer displays the current HP-IB address.
2. Use the numeric keypad to enter a new address (0 through 29), and terminate the entry with the ENT key. The analyzer shows the new HP-IB address and stores it in memory.

Be sure that the address you set for each instrument matches the address physically set on the instrument.

SAVE — Save Menus

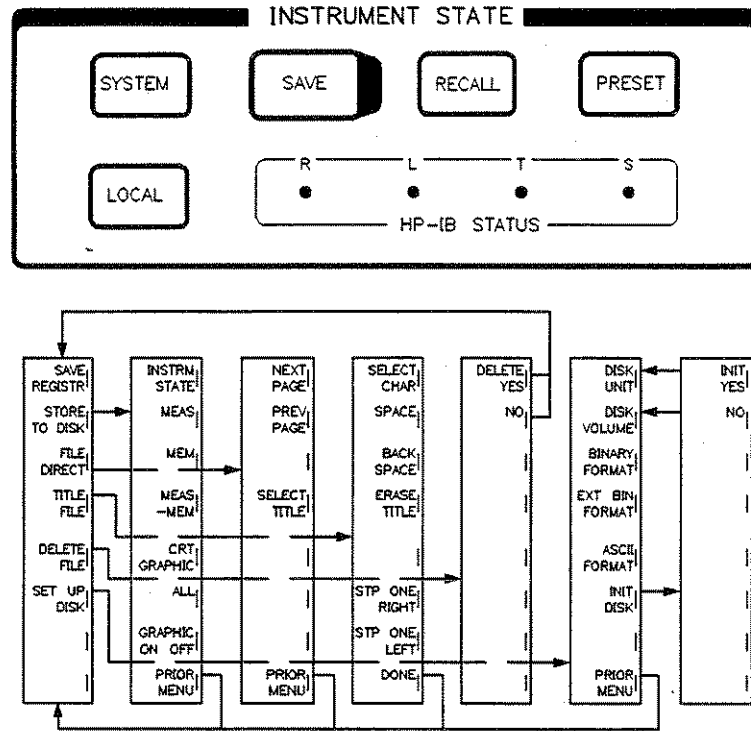

Figure 5-4. **SAVE** Key and Save Menus

The **SAVE** key allows you to save the current instrument state in the analyzer's save/recall registers (non-volatile memory) or to store the instrument states, measurement data, data in memory, and display graphics to a disk.

SAVE

SAVE REGISTR saves the current instrument state in a storage register. The active entry area displays **SAVE REG**. Using the numeric keypad, you can enter the number of the register where you wish to store the current instrument state (no terminating key is needed). You can store nine different settings in registers 1 through 9. You can save limit lines, memory data (channels 1 and 2), and title in registers 1 through 4 only.

The saved information includes the current front panel settings of the analyzer and source, trace memory, limit lines, and titles. The saved memory trace has 401 data points regardless of the number of points you selected for the measurement.

You can recall saved information from a designated register unless you write over the register contents, or clear the contents with the **CLEAR SAV/RCL** softkey.

Note



You can also save the current instrument state in a register by pressing **SAVE**, entering the number of the storage register.

STORE TO DISK presents a menu that lets you store instrument state, trace data, memory data, and display graphics to disk. You can create a unique file title to identify the information you store. If you don't create a file title, the analyzer will assign the stored information a default file title (for example: FILE1). Refer to the figure below.

If you store the instrument states for an analyzer and source combination, and then load the states into an analyzer with a different source, the original instrument states will apply to the new source. Table 5-4 lists the source settings saved on disk.

Table 5-4. Source Settings Saved on Disk

- | |
|--|
| <ul style="list-style-type: none">• ALC mode (internal, external, power meter)• CF/ΔF frequencies• CW frequency• display multiplier• display offset (HP 8350B only)• display update on/off• marker delta• marker sweep• markers 1 through 5• power slope• power sweep• RF power (on/off, value)• square wave modulation on/off (HP 8350B only)
 or shift pulse modulation on/off (HP 8340/41/60)
 or scalar pulse modulation on/off (HP 83750)• start/stop frequencies• sweep mode (start/stop, CF/ΔF, CW, swept CW)• sweep time• sweep trigger (internal, line, external)• sweep type (manual, external, continuous) |
|--|

Notes

You cannot save alternate state information or HP 8360 and 83750 Series user flatness data to disk.

Before you store anything to a new disk, you must initialize the disk. You must also identify the disk unit where the disk resides, and the disk volume number of a hard disk drive (see **SET UP DISK**).

INSTRM STATE stores the analyzer and source front panel settings to disk. The stored information is assigned the file title that is shown on the analyzer. If the stored instrument state data already exists under this file title, the analyzer writes the new data over the old data. You can create a new title by pressing **TITLE FILE** in the save menu.

MEAS stores the trace measurement data to disk. The displayed title will be assigned to the data file unless you create a new file title.

MEM stores the trace memory data to disk. The displayed title will be assigned to the data file unless you create a new file title.

MEAS-MEM Stores normalized trace data to disk. The displayed title will be assigned to the data file unless you create a new file title.

CRT GRAPHIC stores current analyzer graphics to disk. The displayed title will be assigned to the data file unless you create a new file title.

ALL stores the instrument state, trace measurement, normalized trace, memory, and analyzer graphics to disk in one operation. This information is stored in separate files under the active file title.

Note

When accessing stored data from a computer's disk drive, you will see that the filename is a combination of the file title displayed in the HP 8757 directory list plus a two letter suffix. The following list shows the list of possible file title suffixes and the corresponding definitions:

IS - instrument state

Dx - data for channel x

Mx - memory for channel x

Nx - normalized (MEAS-MEM)

CG - CRT graphics

x = 1, 2, 3, or 4

For example, the disk file "FILE1N3" contains MEAS-MEM for channel 3 and would be listed as FILE 1 normalization on the HP 8757 file directory.

SAVE

GRAPHIC ON OFF toggles recalled graphics on and off. When this function is activated, the analyzer only shows graphics and softkey menus. (This key only appears if the display list contains a user generated display graphic.)

An example of how you might use this function is when you want to access an instrument connection diagram at any time during a measurement process.

GRAPHIC OFF turns off the graphics and returns the instrument state and measurement data.

FILE DIRECT shows you the directory of files on the specified disk. The directory can contain up to 382 files, with 16 files to a page.

<u>FILE TITLE</u>	<u>DESCRIPTION</u>	<u>CREATED</u>
→ FILE1	Bin Instr State	29 Jan 93 14:08
FILE1	ASC Meas CH 1 101	29 Jan 93 14:08
FILE1	ASC Memory CH 1 101	29 Jan 93 14:08
FILE1	ASC Nrmlyz CH 1 101	29 Jan 93 14:08
FILE2	Bin Instr State	29 Jan 93 14:08
FILE2	ASC Meas CH 1 201	29 Jan 93 14:08
FILE2	ASC Memory CH 1 201	29 Jan 93 14:08
FILE2	ASC Nrmlyz CH 1 201	29 Jan 93 14:08
FILE2	ASC Meas CH 2 201	29 Jan 93 14:08
FILE2	ASC Memory CH 2 201	29 Jan 93 14:08
FILE2	ASC Nrmlyz CH 2 201	29 Jan 93 14:08
FILE3	Bin Instr State	29 Jan 93 14:08
FILE3	ASC Meas CH 1 401	29 Jan 93 14:08
FILE3	ASC Memory CH 1 401	29 Jan 93 14:08
FILE3	ASC Nrmlyz CH 1 401	29 Jan 93 14:08
FILE3	ASC Meas CH 2 401	29 Jan 93 14:08

Figure 5-5. Directory of Stored Files

NEXT PAGE shows you successive pages of the directory.

PREV PAGE shows you previous pages of the directory.

SELECT TITLE lets you select the active file title. The active file title appears at the top of the analyzer display. To select a file title, use the analyzer knob, or **↑** **↓** keys to scroll through the directory and point to your title choice. Press **SELECT TITLE** to make your title selection.

TITLE FILE lets you create a new file title. The title area displays the current active file title. To create a new file title, first erase the active file title. Then enter up to eight characters. The title area shows the new title as you create it.

SELECT CHAR enters your character selection. Turn the analyzer knob to point to your character choice. Press **SELECT CHAR** and the character will appear in the title area.

SPACE enters a space character in your title.

BACK SPACE deletes the last character entered in the title.

ERASE TITLE deletes the entire title.

STP ONE RIGHT moves the arrow pointer to the next character to the right.

STP ONE LEFT moves the arrow pointer to the next character to the left.

DONE terminates entry of the title and returns the previous menu.

DELETE FILE deletes all the files from the directory that have the same file title. For example, FILE1. Selecting **DELETE FILE** shows you the active file title. Make sure that the files you wish to delete are active.

DELETE YES deletes all files in the directory with the active file title. If you wish to delete the files with the active file titles, press **DELETE YES**.

NO exits the delete file menu without deleting any files. If you want to delete files other than the current active file, use **SELECT TITLE** or the file directory to change the active file title.

SET UP DISK presents another menu that lets you set the disk unit and volume numbers, initialize disks, and define the format.

DISK UNIT shows the unit of the disk drive where the analyzer expects to find your disk. When you select **DISK UNIT**, **DISK UNIT** appears in the analyzer active entry area, along with the unit number of the drive.

To change the unit number, use the numeric keypad to enter the new unit number and terminate the entry with the **ENT** key.

DISK VOLUME shows you which volume of the disk drive the analyzer will access to save and recall data. When you select this softkey, **DISK VOLUME** appears in the analyzer active entry area, along with the drive volume number. The correct volume number is critical when using a hard disk. To change the volume number, use the numeric keypad to enter the new volume number and terminate the entry with the **ENT** key.

BINARY FORMAT sets the measurement and memory data format to binary. Binary format provides the fastest transfer speed of data, includes the detector offset, and uses the smallest storage space of the two formats available (binary and ASCII). The analyzer highlights and underlines the chosen format, and presets to binary format.

SAVE

EXT BIN FORMAT sets the measurement and memory data format to binary. Binary format provides the fastest transfer speed of data, and uses the smallest storage space of the two formats available (binary and ASCII). The analyzer highlights and underlines the chosen format, and presets to binary format.

ASCII FORMAT sets the measurement and memory data format to CITTI file format which is a version of an ASCII format. This format makes the stored data compatible with other computers.

INIT DISK lets you initialize a disk. The analyzer initializes the disk identified by **DISK UNIT** and **DISK VOLUME**. Be certain these are correctly set before continuing.

INIT YES begins the initialization. When the initialization process is complete, the message **WAITING FOR DISK** disappears from the analyzer display and the disk drive light turns off.

Notes

It can take up to 30 minutes to initialize a hard disk.



For a write-protected disk, the analyzer displays **WARNING: DISK IS WRITE PROTECTED** and the initialization process aborts. If you still wish to initialize the disk, remove the write protection and select **INIT DISK** **INIT YES**.

NO displays the previous menu without running the initialization. It does *not* abort an initialization already in progress.

RECALL — Recall Menus

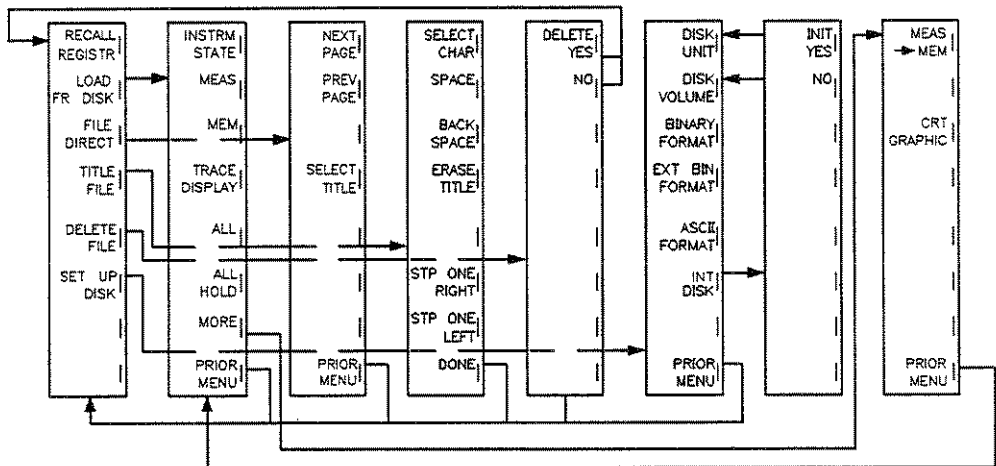
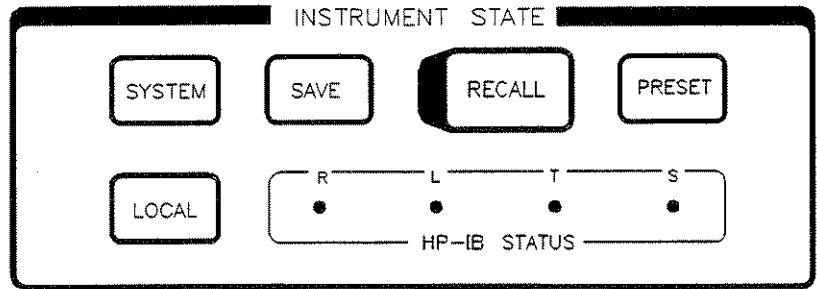

Figure 5-6. RECALL Key and Recall Menus

RECALL accesses function that allow you to recall information previously saved in the analyzer registers or on a disk.

RECALL REGISTR allows you to recall information saved in an analyzer storage register. Use the numeric keypad to enter the number of the register that contains the information you wish to recall (no terminator required). The analyzer retrieves the information saved in that register, then **COMPLETE** appears in the active entry area.

LOAD FR DISK presents a menu that lets you load the instrument state, trace data, and analyzer graphics from disk. The active file title (in the title area) identifies the file to load. If you want to load information from a different file, press **PRIOR MENU FILE DIRECT** and select the file title of the desired file. Then press **LOAD FR DISK** again.

RECALL

INSTRM STATE loads instrument front panel settings from disk. This information must have been previously stored under the current active file title.

MEAS loads the measurement data from the disk into the measurement array for each channel that has a file with the Dx suffix, where x is the channel number. The analyzer holds the trace, which means that the measurement data is no longer updated until you turn **DISPLAY - HOLD** off. You can use the display, scale, ref, spl - smooth, and cursor functions to display this data. A printer or plotter can generate a hardcopy of the displayed trace.

MEM loads trace memory data that was stored on disk. This information must have been previously stored under the current active file title.

TRACE DISPLAY loads the trace data from the disk into the trace array for each channel that has a file with the Nx suffix, where x is the channel number. The analyzer holds the trace, which means that the measurement data is no longer updated until you turn **DISPLAY - HOLD** off. You can use the scale, ref, and cursor functions to display this data. A printer or plotter can generate a hardcopy of the displayed trace.

ALL loads the instrument state, trace measurement and memory, and display graphics from disk in one operation. This information must have been previously stored under the current active file title.

ALL HOLD loads the instrument state (IS suffix), measurement data (Dx suffix), and/or the trace data (Nx suffix) from the disk. If the instrument state file and at least one of the two data files are found, then the measurement data is no longer updated until you turn **DISPLAY - HOLD** off. If trace data is loaded, you can view the data with the scale, ref, and cursor functions. If measurement data is loaded, you can view the data with the display, scale, ref, spl - smooth, and cursor functions. A printer or plotter can generate a hardcopy of the displayed trace.

Note

If the stored file has smoothed data, smoothing turns off.



MEAS→MEM loads trace measurement data from disk into the analyzer trace memory. This information must have been previously stored under the current active file title.

CRT GRAPHICS loads CRT graphics from disk. This information must have been previously stored under the current active file title.

FILE DIRECT shows you the directory of files on the specified disk. The directory holds 382 files, with 16 files to a page.

NEXT PAGE shows you successive pages of the directory.

PREV PAGE shows you previous pages of the directory.

SELECT TITLE lets you select a file title to be the active file title. The current active file title appears at the top of the CRT. Use the analyzer knob to move the arrow to the file title you wish to be the active file title. Press **SELECT TITLE**.

TITLE FILE allows you to define a new file title. The current active file title appears in the CRT title area. To create a new file title, first erase the active file title. Then enter up to eight characters. The new title appears in the title area as you create it.

SELECT CHAR enters your character selections for the file title. Turn the analyzer knob or repeatedly press the **STP ONE RIGHT** or **STP ONE LEFT** softkey until the arrow points to your character choice. Press **SELECT CHAR** and the character will appear in the title area.

SPACE enters a space character in your file title.

BACK SPACE deletes the last character entered in the file title.

ERASE TITLE deletes the entire file title.

STP ONE RIGHT moves the arrow pointer to the next character to the right.

STP ONE LEFT moves the arrow pointer to the next character to the left.

DONE terminates entry of the file title and displays the previous menu.

DELETE FILE deletes all the files from the directory that have a common title. For example, FILE1. Pressing **DELETE FILE** shows you the active file title. Make sure that the files you wish to delete are active.

DELETE YES deletes all files in the directory with the active file title. If you do wish to delete the files with the active file titles, press **DELETE YES**.

NO exits the delete file menu without deleting any files. If you want to delete files other than the current active file, use **SELECT TITLE** or the file directory to change the active file title.

RECALL

SET UP DISK presents another menu that lets you set disk unit and volume numbers, initialize disks, and define the format in which to save the data.

DISK UNIT shows you the unit of the disk drive where the analyzer expects to find your disk. To change the unit number, use the numeric keypad to enter the new unit number and terminate the entry with the **ENT** key.

DISK VOLUME shows you which volume of the disk drive the analyzer will access to save and recall data. To change the volume number, use the numeric keypad to enter the new volume number and terminate the entry with the **ENT** key.

BINARY FORMAT sets the measurement and memory data format to binary. Binary format provides the fastest transfer speed of data, includes the detector offset, and uses the smallest storage space of the two formats available (binary and ASCII). The analyzer highlights and underlines the chosen format, and presets to binary format.

EXT BIN FORMAT sets the measurement and memory data format to extended binary. Extended binary format extends the range limits beyond the binary format (for ratio, normalized ratio, power and normalized power measurements only). The range extension is a function of the analyzer's detector amplitude offset. This format excludes the detector offset; the value of the detector offset is contained in the instrument state file.

ASCII FORMAT sets the measurement and memory data format to ASCII. ASCII format makes the stored data compatible with other computers.

INIT DISK lets you initialize a disk. The analyzer will initialize the disk identified by **DISK UNIT** and **DISK VOLUME**. Be certain these are correctly set before continuing.

INIT YES begins the initialization. The message **WAITING FOR DISK** appears on the analyzer display. When the disk is initialized, this message disappears and the disk drive light turns off.

Note



For a write-protected disk, the analyzer displays the message **WARNING: DISK IS WRITE PROTECTED**, and the initialization aborts. If you still wish to initialize the disk, remove the write protection and press **INIT DISK** **INIT YES**.

NO returns the previous menu without running the initialization. It will *not* abort an initialization already in progress.

PRESET — Preset Key

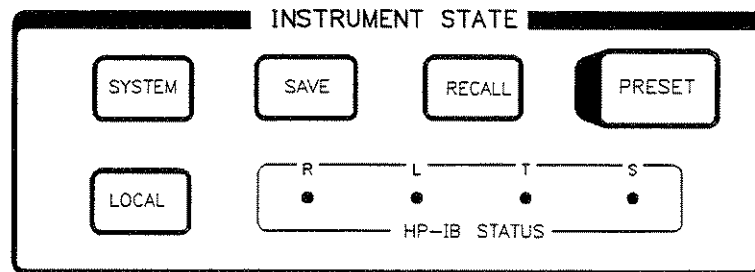

Figure 5-7. PRESET Key

When you press **PRESET**, or when the analyzer receives the IP command from a system controller, the analyzer performs a self-test and then presets all of the instruments connected to the HP 8757 system interface. All of the instrument's functions are turned off and the following states are set:

Analyzer

- power measurement A on channel 1 (on)
- power measurement B on channel 2 (on)
- power measurement C (or B) on channel 3 (off)
- power measurement R on channel 4 (off)
- measurement data in log magnitude format
- scale = 20 dB/div log; 10 dB/div SWR
- reference level = 0 dBm for all channels log; 1.0 SWR
- reference level step size = 20 dB
- averaging is off
- averaging factor = 8
- cursor is off
- all labels are on
- channel 1 is the active channel
- modulation drive is on
- number of trace points = 401
- detector mode is set for AC detection
- smoothing aperture is set for 5.0% of span (off)
- cursor format = log magnitude

PRESET

- search value = -3 dB
- adaptive normalization is off
- temperature compensation is on
- autocal is on
- repeat autozero is off
- detector offset = 0 dB
- detector frequency is off
- cursor and delta cursor position = 200
- user start/stop frequency = 50 MHz
- detector start/stop frequency = 50 MHz
- memory offset = 0 dB
- service request mask = 0 (if front panel preset)
- non standard sweep is off
- limit lines are off
- frequency labels are unblanked
- disk format = binary
- detector offset calibrator power = 0 dBm
- non swept CW is off
- manual sweep is off
- stepped sweep is off
- data output format = ASCII

Source

- instrument preset
- sweep time = 200 ms
- HP 8350B square wave modulation is on
- HP 8340/8341 SHIFT PULSE on; RF output is on
- HP 8360 scalar modulation on; RF output is on

Plotter

- plot is aborted, if in progress
- P1 and P2 scaling points are unchanged
- selection of plotter pens are unchanged

Printer

- plot or print is aborted, if in progress

Disk Drive

- data transfer in progress is aborted
- unit number is unchanged
- volume number is unchanged
- ASCII or binary mode is unchanged

Unchanged Analyzer Conditions

PRESET and the IP command do not change the following analyzer conditions:

- reference position
- trace memory
- save/recall registers
- HP-IB addresses
- service request mask (if remote preset "IP")
- limit lines
- title
- user-defined plot
- HP 8757 system interface private bus control on/off
- repeat autozero timer
- display intensity
- display colors
- time stamp on/off
- plotter/printer buffer on/off

1
2
3
4
5
6
7
8
9
10
11
12
13
14
15
16
17
18
19
20
21
22
23
24
25
26
27
28
29
30
31
32
33
34
35
36
37
38
39
40
41
42
43
44
45
46
47
48
49
50
51
52
53
54
55
56
57
58
59
60
61
62
63
64
65
66
67
68
69
70
71
72
73
74
75
76
77
78
79
80
81
82
83
84
85
86
87
88
89
90
91
92
93
94
95
96
97
98
99
100



Rear Panel Features

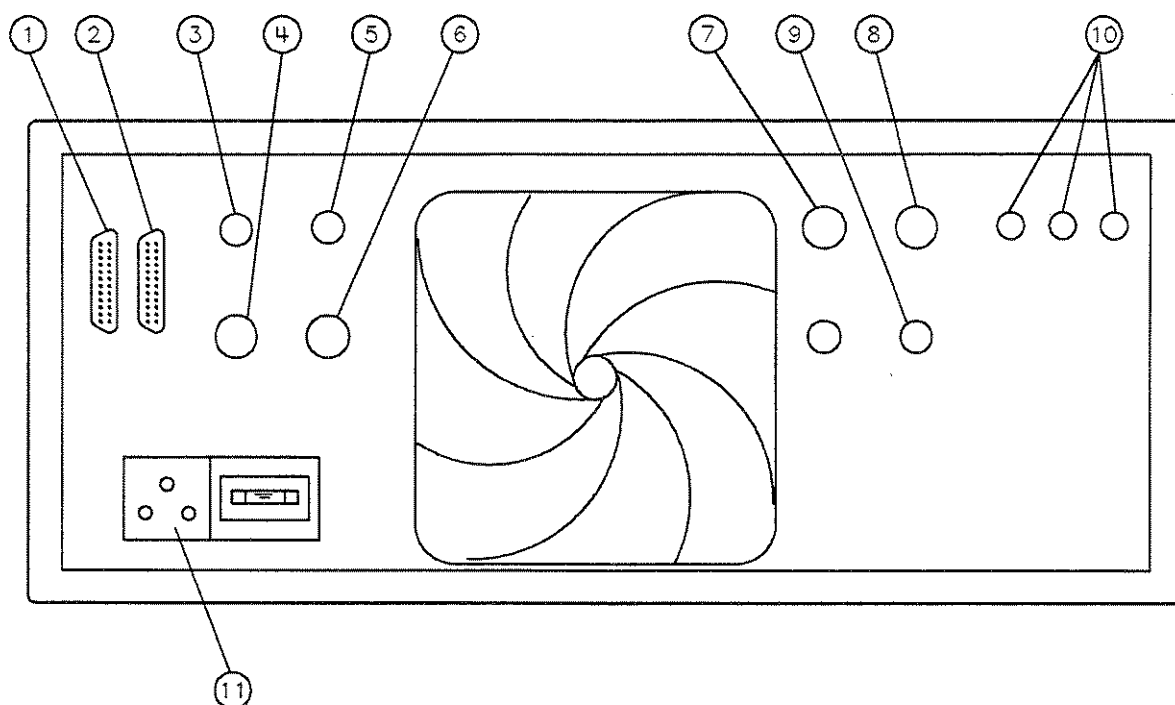

Figure 6-1. The HP 8757D Rear Panel

- ① **8757 SYSTEM INTERFACE** This interface is a private bus that lets the analyzer control peripherals such as the source, plotter, and printer. Since the analyzer itself controls the HP 8757 system interface bus, other controllers must not be attached to this connector, unless the **SYSINTF ON OFF** function is *off*.

With a system interface establishing a communication between the instruments, the analyzer can detect and display the source frequency information.
- ② **HP INTERFACE BUS** This interface bus allows the analyzer to interface with a computer controller and other HP-IB instruments.
- ③ **POS Z BLANK** This input accepts positive retrace, bandswitch blanking, and negative intensity marker (z-axis modulation) signals. The signal levels sensed on this input are +5 V for blanking, 0 V for display, -4 V for markers, and -8 V for the active marker.

Rear Panel Features

- ④ **SWEEP IN 0-10V** This input accepts a source sweep ramp signal that can be anywhere between 0 to +10 volts. You can modify the A4 ADC assembly so the analyzer can accept sweep ramps greater than +10V. The sweep in signal is necessary for the analyzer to operate as a receiver. An HP 83750 source creates a pulse train that consists of 1μ second pulses in both continuous and step sweep modes.
- ⑤ **STOP SWEEP** This connector provides the interface signal to stop a source's sweep when it is controlled over the system interface.

The analyzer also uses this connector to sense when the source has stopped the sweep.

- ⑥ **MODULATOR DRIVE** This output provides a 27.778 kHz square wave signal, (nominally ± 6 V open circuit), for driving an external modulator, a source's external amplitude, or pulse modulation input.
- ⑦ **DAC OUT 0-10V** This connector is provided for future enhancements included with later firmware revisions. You can also use this output for troubleshooting.
- ⑧ **ADC IN** This connector shows an external voltage on the analyzer display using **MEAS AUX**. The connector is also referred to as AUX input. You can also use this input for troubleshooting.
- ⑨ **CONTROL 1 and CONTROL 2** These connectors provide digital output signals (TTL open-collector) as a convenience for driving other peripheral equipment in an HP-IB controlled system. The CONTROL 1 signal can be used as an oscilloscope trigger source when continuous loop service-related tests are performed.
- ⑩ **R, G, and B VIDEO OUTPUT** These connectors provide analog red, green, and blue video signals that you can use to drive an external color monitor or monochrome monitor. Any analog multisync monitor can be used if it is compatible with the analyzer's 25.5 kHz scan rate and video levels (1 V p-p, 0.7 V = white, 0 V = black, -0.3 V = sync, sync on green).
- ⑪ **LINE V $\pm 10\%$** This input connector accepts primary line voltage (100, 120, 220, or 240 V) to power the analyzer. Use the printed circuit selector board to set the correct line voltage. See chapter 2, "Installation," for information on line voltage and fuse selection.

Operator's Check

Equipment Required

HP-IB cable	HP 10833A/B/C/D
sweep oscillator mainframe	HP 8350B
RF plug-in	HP 83592B
detector	HP 85037A/B
50 MHz bandpass filter	HP PN 08757-80027
graphics plotter	HP 7440A

Description

The operator's check procedure verifies that the analyzer is functioning correctly. It does not verify all of the instrument specifications, but it is an appropriate test for daily instrument verification, incoming inspection, or verification after repair or replacement of digital circuits. The procedure consists of HP-IB and system interface checks, self-tests, and an insertion loss measurement of a standard device.

Save the insertion loss data as a reference for comparison with future operator's checks. Keep the standard device exclusively for these operator's checks to minimize device variation. You can modify this procedure to use other test devices and frequency ranges. But, to test the analyzer's full dynamic range, your source must output +16 dBm.

Procedure

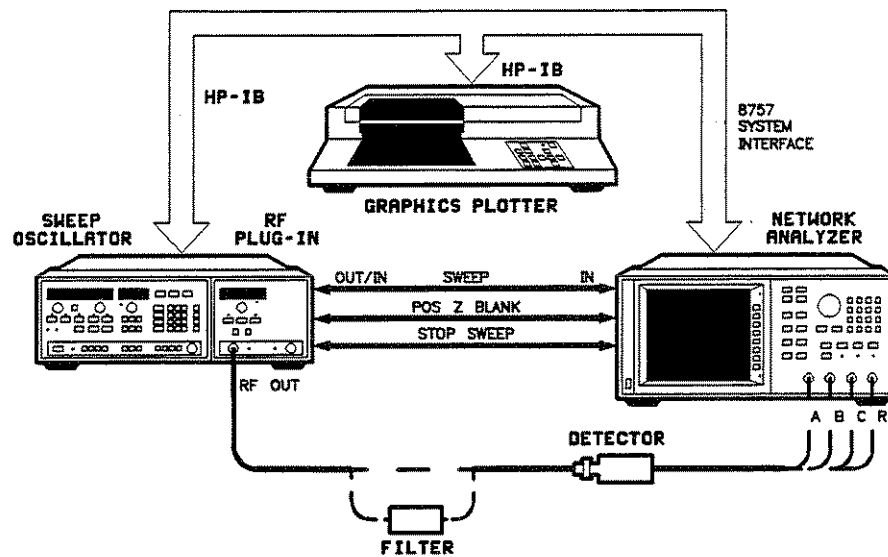

Figure A-1. Operator's Check Equipment Set-up

1. To verify the instrument self-test, HP-IB, and system interface, perform the "HP Interface Bus and HP 8757 System Interface" test in chapter 4 of the service manual.
2. Set up the equipment as shown in Figure A-1, with the detector connected to input A of the analyzer. Connect the detector's RF input to the RF output of the source for a "thru" (0 dB insertion loss) connection. Turn on the instruments and allow 30 minutes warm-up time.
3. If the HP 8757 system interface is not engaged (the analyzer status line displays SYSINTF OFF), press **SYSTEM** **MORE** **SWEEP MODE** **SYSINTF ON**.
4. On the analyzer, press **PRESET**. The analyzer channel 1 should be active and measuring input A.
5. Adjust the start and stop frequencies of your source to include the frequency range of your microwave test device.
These frequencies will be plotted with the data.
6. Turn off the analyzer's channel 2 by pressing **CHANNEL** **2** twice.
7. On the analyzer, press **CURSOR** **MAX** to place the cursor at the maximum value of the trace. The CRSR value is displayed in the active entry area of the analyzer. Adjust the output power of the RF plug-in until the cursor value on the analyzer reads +16 dBm. This value is the upper limit of the dynamic range of the analyzer.
8. Press **DISPLAY** **MEAS** **MEM** to store the trace in memory. The analyzer message line displays CHAN 1 MEAS TO MEMORY.

9. Disconnect the detector from the RF output of the source. Press **AVG** **AVG ON OFF** to turn on averaging with an average factor of 8. Wait a few seconds to allow the trace to settle.
10. Press **CURSOR** **MAX**. A cursor value of -60 dBm or lower should be displayed in the active entry area. This is the noise floor power level.
11. Insert your test device between the RF output of the source and the detector. On the analyzer, press **DISPLAY** **MEAS-MEM**. Wait a few seconds to allow the trace to settle.
12. Press **CURSOR** **MAX** to find the trace maximum. The CRSR value displayed in the active entry area now represents the minimum insertion loss of your test device. This value will be plotted with the data trace.
13. Press **SYSTEM** **PLOT** **PLOT ALL** to generate a hard copy plot. Keep this plot for comparison with results of future operator's checks.
14. Disconnect the detector from the A input and connect it to the B input. Remove your test device from the circuit and connect the input of the detector to the RF output of the source. Press **DISPLAY** **MEAS** **MEAS** **B** **AVG** **AVG OFF**. Repeat steps 7 through 13.
15. Repeat step 14 for the remaining detector inputs, pressing **MEAS** and selecting the softkey that corresponds to the detector input connected.

1
2
3
4
5
6
7
8
9
10
11
12
13
14
15
16
17
18
19
20
21
22
23
24
25
26
27
28
29
30
31
32
33
34
35
36
37
38
39
40
41
42
43
44
45
46
47
48
49
50
51
52
53
54
55
56
57
58
59
60
61
62
63
64
65
66
67
68
69
70
71
72
73
74
75
76
77
78
79
80
81
82
83
84
85
86
87
88
89
90
91
92
93
94
95
96
97
98
99
100



Softkey Menu Structure Maps

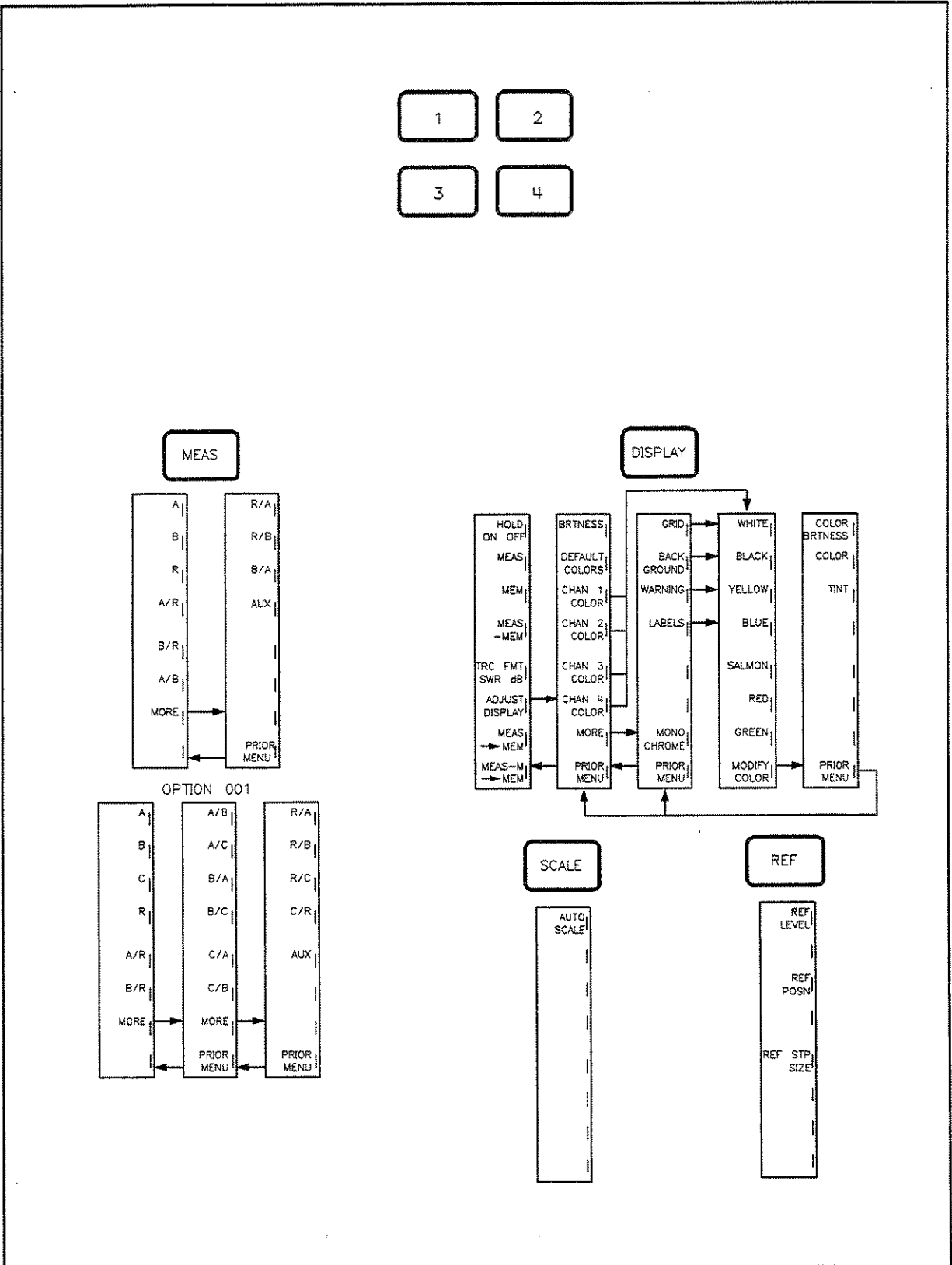

Figure B-1. HP 8757D Softkey Menu Structure Map

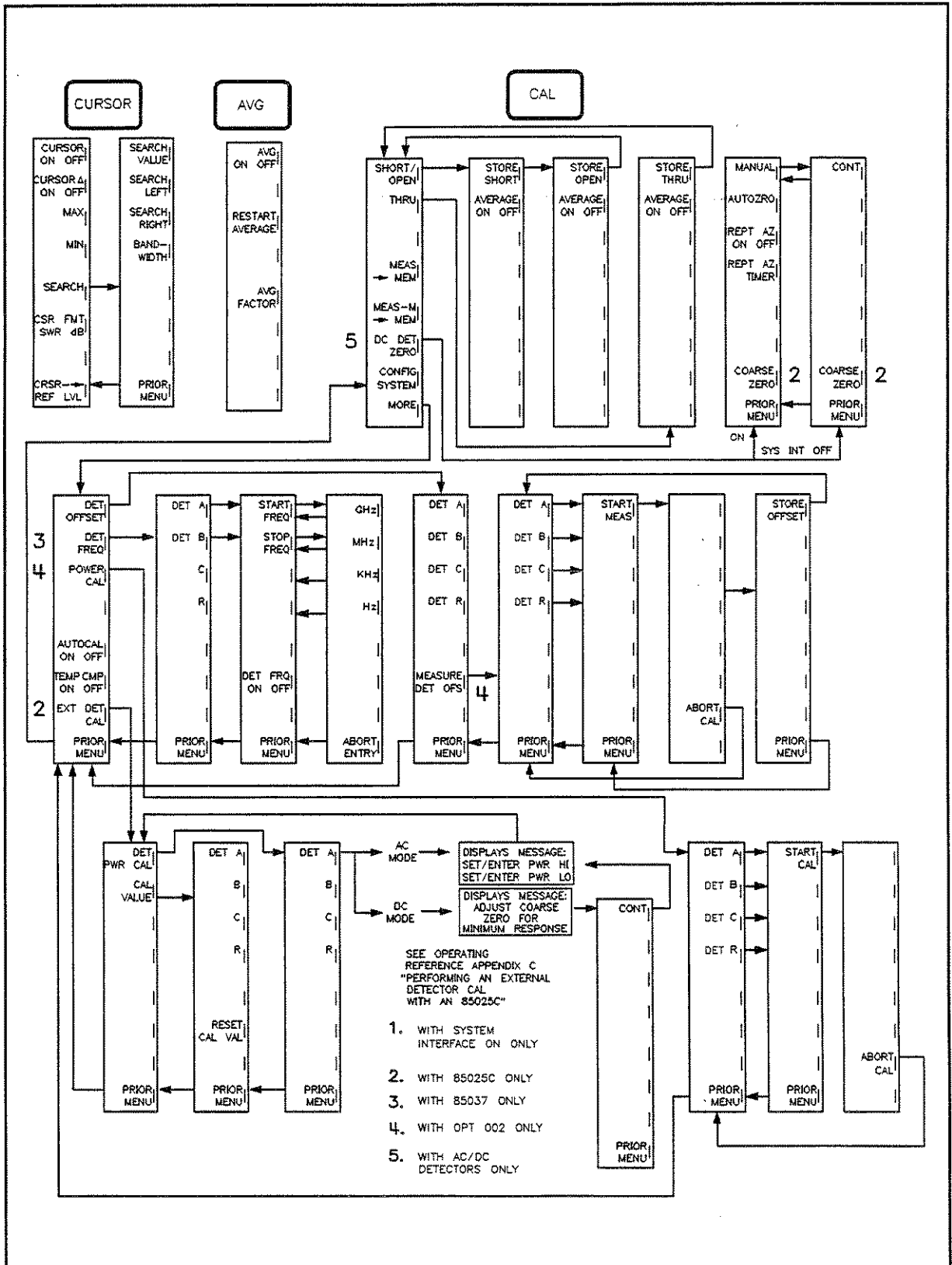

Figure B-2. HP 8757D Softkey Menu Structure Map

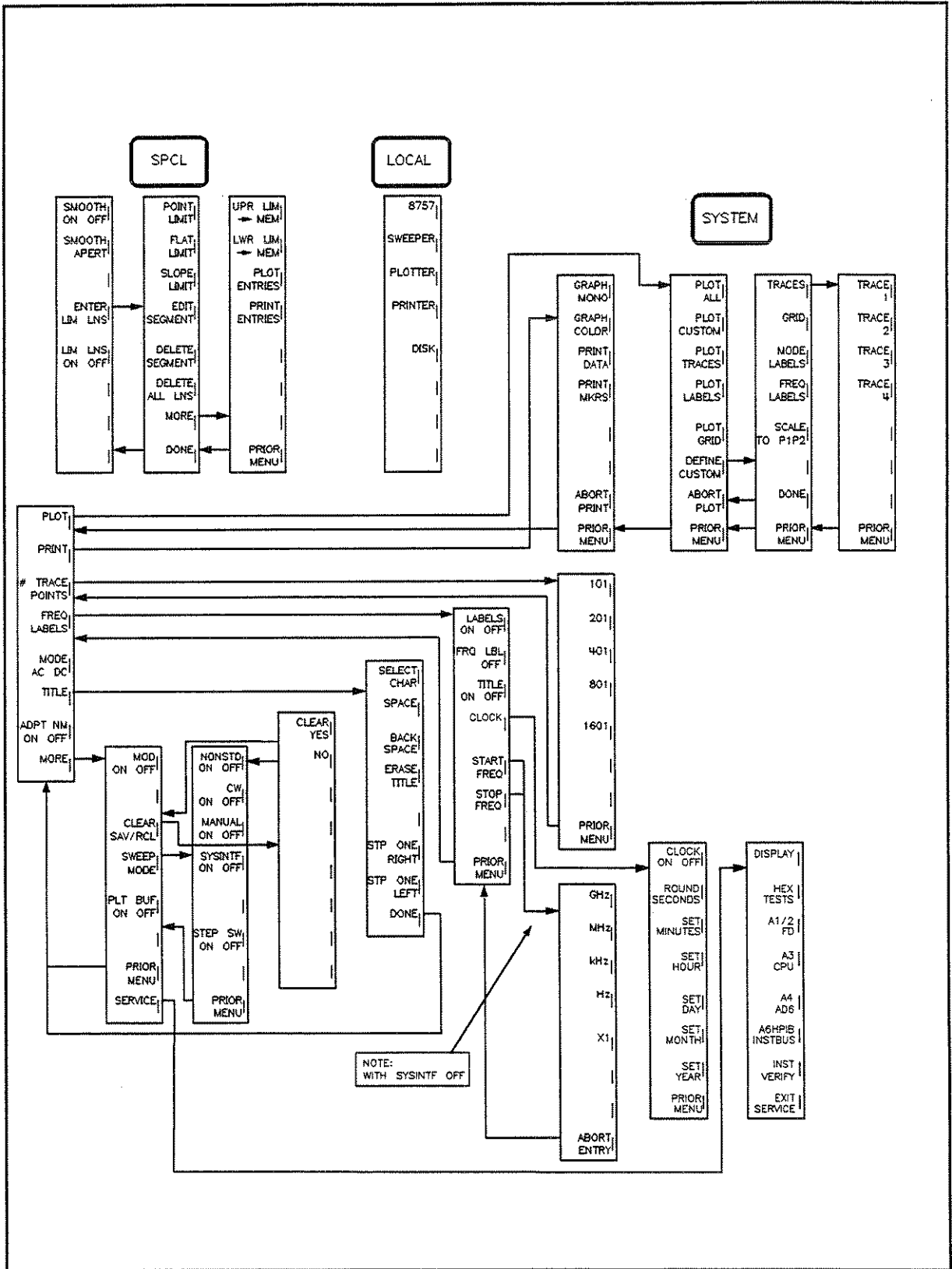

Figure B-3. HP 8757D Softkey Menu Structure Map

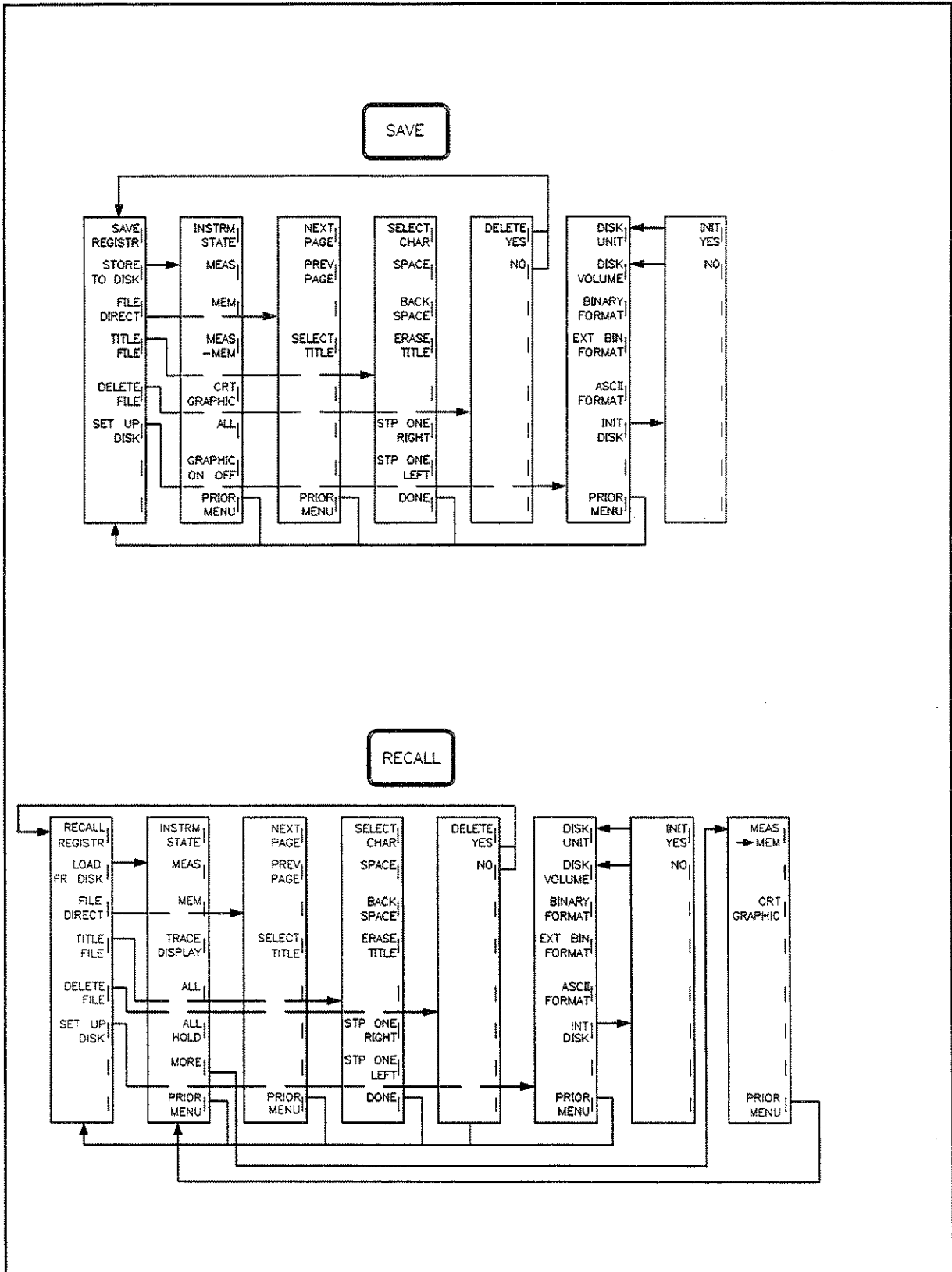

Figure B-4. HP 8757D Softkey Menu Structure Map

THE UNIVERSITY OF MICHIGAN LIBRARY



Performing an External Calibration

Performing an External Detector Calibration with an HP 85025C

Because the HP 85025C is used with an external (separate) detector diode, you should perform a firmware based measurement calibration procedure. This external detector measurement calibration procedure calibrates the analyzer's dynamic range to each detector diode and detector adapter. You should perform this procedure whenever you connect a detector diode and adapter to a different input, or if you change either the detector or the adapter.

External Detector Measurement Calibration

The response of the diode's output voltage versus input power is described by a general equation within the HP 8757D. To adapt this equation to describe your particular detector, the analyzer uses data measured at two points on the detector's power range. The external detector measurement calibration requires that you measure two different power levels (HI and LO) and that you enter the exact values of the power levels. For best results, the HI power level should be in the diode detector's linear region of operation, and the LO power level should be in its square law region. The power levels +6 and -24 dBm used in the following procedure are typical examples. The power levels you choose depend on the response of your diode detector, and the output power of your source.

Equipment required:

- HP 8757D
- HP 85025C detector adapter

On the HP 8757D:

1. Connect the equipment and allow 30 minutes warm up.
2. Press **PRESET**.
3. If you will be using DC detection, press **SYSTEM** and select **MODE AC/DC**.
If you will be using AC detection, continue with Step 4.

NOTE: A measurement calibration in one mode is not valid for the other (see AC versus DC Measurement Calibration below).

4. Press **CAL MORE EXT DET CAL DET PWR CAL**.
5. Select the appropriate input being calibrated, such as **DET A**.

If you are using AC detection, the analyzer displays: ENTER POWER (HI).
Go to Step 8.

If you are using DC detection, the analyzer displays:
Adjust COARSE ZERO for minimum response.

On the HP 85025C:

6. Adjust COARSE ZERO on the detector for a minimum noise level signal on the analyzer.

On the HP 8757D:

7. Select **CONT**.

The analyzer displays ENTER POWER (HI).

8. Connect the detector to an RF source, such as a sweeper.

On the source:

9. Select a CW frequency within the detector's range.

10. Set the power to a level in the detector's square law region greater than -10 dBm (for example, $+6$ dBm). For best accuracy, use a power meter or HP 85037 detector to set the power level.

On the HP 8757D:

13. Enter the power level incident on the detector (for example, 6 dBm). The analyzer displays ENTER POWER (LO).

14. Set the attenuator or source power level so that the power to the detector is in the square law region, and less than -20 dBm (for example, 30 dB of attenuation).

15. Enter the power level incident on the detector (for example, -24 dBm).

The analyzer performs the external detector measurement calibration and displays the DET A(BCR) CAL VAL when it is finished. Record this value for future reference (on the detector diode and detector adapter, if possible).

If you change the detector or the detector adapter, you must perform a new measurement calibration.

The displayed value is retained by the analyzer as long as an HP 85025C is connected to that input. If another detector diode and adapter is connected to the same input, the analyzer uses the first measurement calibration value until you perform a new measurement calibration.

You can bypass the measurement calibration procedure if you select the softkey **CAL VALUE** rather than **DET PWR CAL** in the measurement calibration sequence, and enter the known value for your detector diode and detector adapter.

AC versus DC Measurement Calibration

A measurement calibration performed in one measurement mode may not be valid in the other mode. For the best measurement accuracy, perform a measurement calibration in the mode you will be using.

The difference between an AC and a DC mode measurement calibration depends on the detector you use. All detectors do not respond the same to a modulated RF signal (used in AC detection), some respond very quickly, while others respond more slowly.

A detector that responds very quickly produces an output signal that has the same amplitude in either AC or DC mode.

A detector that responds more slowly, however, produces an output signal that is smaller in amplitude in AC mode than in DC. Because the signal amplitude is not the same in both measurement modes, a power calibration done in one is not valid in the other.

Changing a Stored Measurement Calibration

When you perform the measurement calibration procedure, the analyzer stores the calibration value. The analyzer retains that value unless you change it. You can change a calibration value in three ways:

1. Perform an external detector measurement calibration with a new diode and adapter. The new calibration value replaces the original.
2. Enter a known calibration value manually by pressing: **CAL**, **MORE**, **EXT DET CAL**, **CAL VALUE**, **DET A** (or the appropriate input). The analyzer displays **DET A CAL VAL** and the value stored for that input. Enter the value you wish stored for that input and press **ENT**. The analyzer displays **DET A CAL VAL** and the new value.
3. Use the default calibration value that is stored in the analyzer (see “Uncalibrated Operation” below).

Only one measurement calibration value is stored at a time for each input; the analyzer does not keep separate AC and DC calibration values.

Uncalibrated Operation

When you are making relative measurements at low power levels (in the diode detector’s square law region), you don’t have to perform a measurement calibration. The analyzer has a default calibration value that describes the response of a typical detector diode and adapter. Accurate absolute power measurements, however, do require a calibration.

To set the default value:

Press **CAL**, **MORE**, **EXT DET CAL**, **CAL VALUE**, **DET A** (or the appropriate input) **RESET CAL VAL**.

The analyzer displays **DET A CAL VAL** and the default value.

Zeroing

When you make DC detection measurements, it is important that you perform a zeroing operation to compensate for the effects of DC drift and temperature fluctuations (this is not required for AC detection). The zeroing operation eliminates small DC voltages from the diode detector that would otherwise cause amplitude measurement errors at low (–40 dBm and below) power levels. Zeroing also establishes the displayed noise level (noise floor of the system) with no RF signal applied.

Zeroing the HP 85025C consists of two parts: (1) coarse zero, which compensates for any large offset voltage, and (2) autozero, which compensates for any small drift in the offset voltage.

Coarse Zero:

1. Connect the diode and adapter to the analyzer.

On the HP 8757D:

2. Turn the analyzer on and press **PRESET**. Allow the instruments to warm up for 30 minutes.
3. Press **SYSTEM** **MODE AC/DC** to turn DC mode on.
4. Press **CAL** **DC DET ZERO** **COARSE ZERO**.

5. Select the softkey that corresponds to the detector adapter that you wish to zero (for example, **DET A**). The analyzer displays Adjust COARSE ZERO for minimum response.

On the HP 85025C:

6. Adjust Coarse DC Zero for a minimum signal on the analyzer.

Autozero:

On the HP 8757D:

7. After adjusting coarse zero, press the softkey **CONT**. The analyzer performs an autozero.

If the error voltage is too large for autozero to compensate for, the analyzer displays the message:

WARNING: DC DET ZERO failed on A(BCR).

If this happens, you must adjust coarse zero to bring the error voltage within Autozero range.

Repeat autozero, **REPT AZ ON/OFF**, periodically repeats the autozero. You must use the detector with an HP-IB sweeper to use this function because the HP 8757 must be able to turn off the RF power before performing the autozero.

Manual zero, (**MANUAL**), is similar to zeroing a power meter. First, remove the RF signal from the detector. Then press **MANUAL** to perform the zeroing.

Note



If a device under test generates RF signals or noise, autozero is not valid. Devices that can generate RF energy are microwave amplifiers and mixers with the local oscillator signal applied. If you are testing such devices, use manual zero.

Note



For optimum performance, you should electrically connect the outer conductor of the source RF output connector to the outer conductor of the detector adapter input.

If the operating environment changes significantly, you should repeat the zeroing operation.

Measurement Applications

Mixer Measurements

Equipment Required

- 2 HP 8360 synthesized sweepers
- HP 85037A/B detector
- HP 85027A/B/C bridge
- HP 11667A/B power splitter

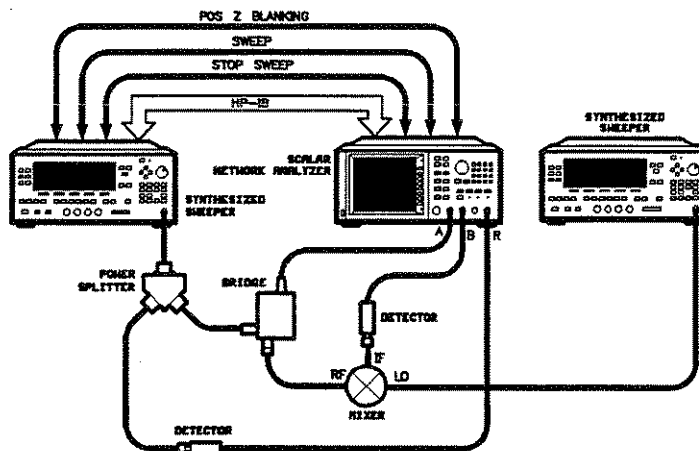

Figure D-1. Mixer Lab Equipment Set-up

Note



The figure above shows the connection for the mixer measurements described in case 1 and case 3 in Table D-1.

If you want to make the mixer measurement described in case 2, you must connect a cable between the HP 83750's AUXILIARY INTERFACE connectors and connect a cable between the HP 83750's 10 MHz REF IN/OUT connectors.

Here are three examples of mixer measurements:

1. Swept RF frequency, Fixed LO, LO < RF Frequency
(LO is not swept.)
2. Swept LO, LO frequency = RF - OFFSET
Note: in this case the LO sweeper must be slaved to the RF sweeper.
3. Fixed LO, LO > RF (The IF signal from the mixer sweeps downward in frequency.)

Table D-1. Three Mixer Measurement Cases

CASE	Main Source RF	External Source LO	Mixer IF out
1) Fixed LO, LO < RF	10 to 15 GHz swept	9 GHz fixed	Start 1 GHz to Stop 6 GHz
2) Swept LO, LO=RF-OFFSET	10 to 15 GHz swept	9 GHz to 14 GHz	1 GHz Fixed
3) Fixed LO, LO > RF	10 to 15 GHz swept	16 GHz fixed	Start 6 GHz to Stop 1 GHz

The HP 85037 precision detector has built-in frequency response correction constants. To obtain the best accuracy in mixer measurements, the detector start and stop frequencies should be entered into the HP 8757D using the **DET FREQ** function. If you don't enter the frequencies into the HP 8757, the analyzer uses the source's frequency settings to create the detector's frequency response corrections. This is recommended when you are making mixer measurements because the HP 8757D uses the source's frequency settings to apply the HP 85037 detector's frequency response corrections.

In mixer measurements, the detector operating frequency will most likely be offset from the source frequency. For example, in case 1:

Press:

CAL

MORE

DET FREQ DET B

START FREQ 1 GHz

STOP FREQ 6 GHz

DET FREQ ON

Refer to the **DET FREQ** section in chapter 4 of the "Operating Reference" for more information.

Remote Operation

Converting Existing HP 8757A Programs

Programs written for an HP 8757A (firmware revision ≥ 2.0) require minimal or no changes to run on an HP 8757D. The major differences involve the graphics commands (see the introductory programming guides and the quick reference guide). To assist in upgrading existing software, review the following list.

Display Graphics (HP-GL Commands)

1. DEFAULT (DF) sets default values. This command (equivalent to: (“DI 1,0; SI 0.14,0.17;”)) places the HP 8757D in *monochrome* mode.
2. LINE TYPE (LT_{y,z}) is not available on the HP 8757D.
3. OUTPUT P1 and P2 POSITION (OP) outputs the current P1 and P2 positions (P1 = lower left position; P2 = upper right position). The graphics display units (GDUs) define the CRT plotting area. Table 2-1 lists the display full page coordinates.

Table 2-1. Display Full-Page Coordinates

HP Analyzer	Lower Left P1(LL)	Upper Right P2(UR)	Trace Graticule	
			(LL)	(UR)
8757A	(0,0)	(2698,2047)	(198,150)	(2307,1814)
8757D	(0,0)	(2924,2047)	(214,150)	(2500,1814)

4. SELECT PEN (SP n) select the beam intensity and color displayed on the CRT. This command operates in three modes:
 - a. Monochrome display mode, set by the (DF) command, uses the (SP n) command to select between three different beam intensities and beam off.
 - b. Color mode, selected (if not already on) with the HP 8757C DEFAULT COLORS command (DEC). The *Quick Reference Guide* lists the colors associated with the different pen numbers.
 - c. HP 9000 series 200/300 BASIC color, set with the HP 8757C BASIC COLORS command (BC). For a list of the colors available, see the *Quick Reference Guide* or the *BASIC 5.0 Condensed Reference*.

Softkey Locations

If an existing program bases any part of its operation on the HP 8757A menu structure (softkey placement), you must update the program to reflect the menu structure in the HP 8757D.

Learn Strings

HP 8757A learn strings are fully compatible with the HP 8757D.

Preset Timeout

Allow at least 20 seconds after an HP 8757D instrument preset for internal diagnostics to complete.

Quick Reference Guide

For the HP 8757D/E Scalar Network Analyzer

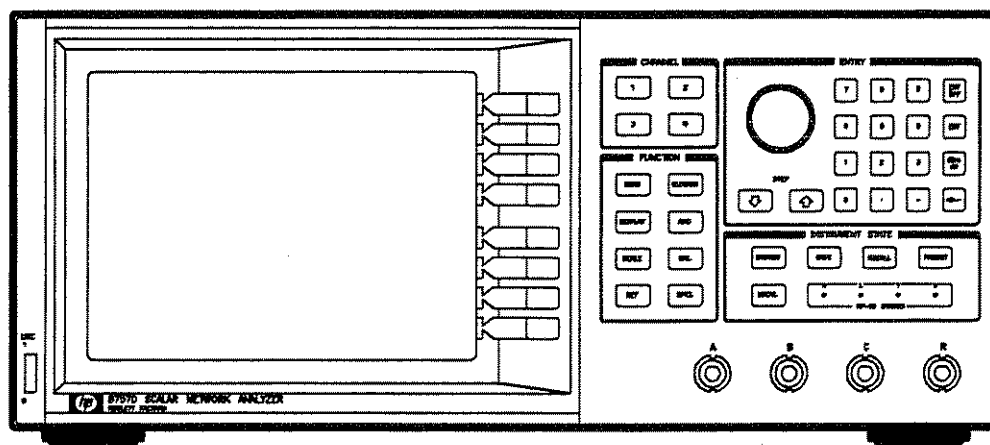

Introduction

This programming note is a reference guide for the remote operation of the HP 8757D/E Scalar Network Analyzer with firmware revision 4.2 or greater. This note is intended for use by those familiar with HP-IB programming and the basic functions of the HP 8757D/E. For operation information for the analyzer, refer to the *Operating Reference* in the operating manual.

Note: Remote operation of the HP 8757D/E applies to operation with the HP Interface Bus (HP-IB) connector on the rear panel of the analyzer. Do not connect an HP-IB controller to the 8757 SYSTEM INTERFACE connector; HP-IB control of the instruments connected to this port is described in the "Passthrough" portion of this document.

HP-IB capabilities

The following codes describe the HP-IB electrical capabilities of the HP 8757D/E, using IEEE Std 488-1978 mnemonics (HP-IB, GP-IB, IEEE 488, and IEC-625 are all electrically equivalent). The mnemonics briefly translate as follows:

- SH1: Source Handshake, complete capability.
- AH1: Acceptor Handshake, complete capability.
- T6: Talker, capable of basic talker, serial poll, and unaddress if MLA.
- TE0: Talker, Extended address; no capability.
- L4: Listener, capable of basic listener, and unaddress if MTA.
- LE0: Listener, Extended address; no capability.
- SR1: Service Request, complete capability.
- RL1: Remote Local, complete capability.
- PP0: Parallel Poll, no capability.
- DC1: Device Clear, complete capability.
- DT0: Device Trigger, no capability.
- C0: Controller, no capability.
- E1: Electrical specification indicating open collector outputs.

These codes are completely explained in the IEEE Std 488-1978 document, published by the Institute of Electrical and Electronic Engineers, Inc., 345 East 47th Street, New York, New York 11017.

Input data

The HP 8757D/E Scalar Network Analyzer accepts specific programming commands for selecting front panel key functions, most softkey functions and special HP-IB only functions. Line switch control and HP-IB address setting are not programmable. The analyzer can pass through HP-IB commands to a compatible Hewlett-Packard swept source, graphics plotter, and printer, connected to the 8757 SYSTEM INTERFACE. A list of compatible instruments is given in "8757 System Interface". In addition, some Hewlett-Packard Graphics Language (HP-GL) commands may be passed through to the CRT.

Programming data consists of a string of ASCII coded characters composed of one or more of the following control fields:

- Select channel
- Measure power/ratio
- Display measured data/memory
- Select scale
- Select reference value/position

Input syntax #1: function code

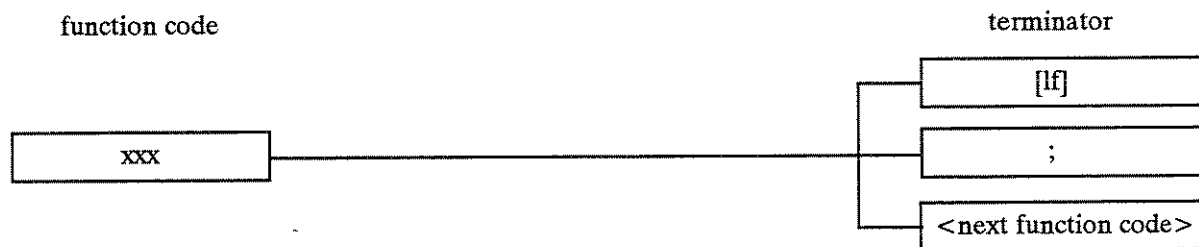

Example: "C1 IA;ME[lf]"

Select channel 1 (C1), measure the power at the A detector (IA), display measured data (ME) on the CRT.

Input syntax #2: function code followed by a single digit numeric

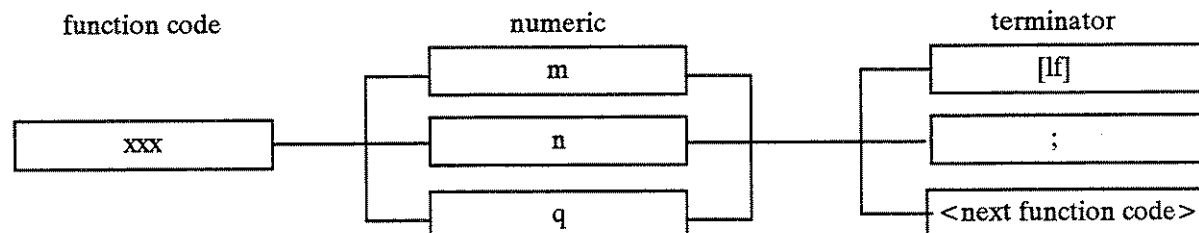

where: m = 0 function off
m = 1 function on
n = decimal integer 1 through 9
q = value unique to the particular function and explained under command description

Example: "MD1;RP4SV9[lf]"

Turn the square wave modulation on (MD1), set the reference position to the 4th graticule (RP4), and then save the front panel setting into register 9 (SV9).

- Select averaging
- Cursor functions
- Plot functions
- HP-GL graphics commands
- Instrument state/registers
- Special HP-IB only functions

Input syntax

The analyzer responds to program commands in the order in which they are received. The commands can be upper or lower case ASCII characters, and must be sent without any intervening alphanumeric characters or digits (spaces are ignored).

There are two input command terminators which can be universally applied to all analyzer input commands: a line feed ([lf]) or a semicolon (;). It is best to terminate all input programming commands with either a line feed or a semicolon. However, there are alternate choices in the use of terminators. Listed below in the syntax diagrams are all of the possible terminators that can be used with the various input commands.

Input syntax #3: function code followed by a variable length numeric

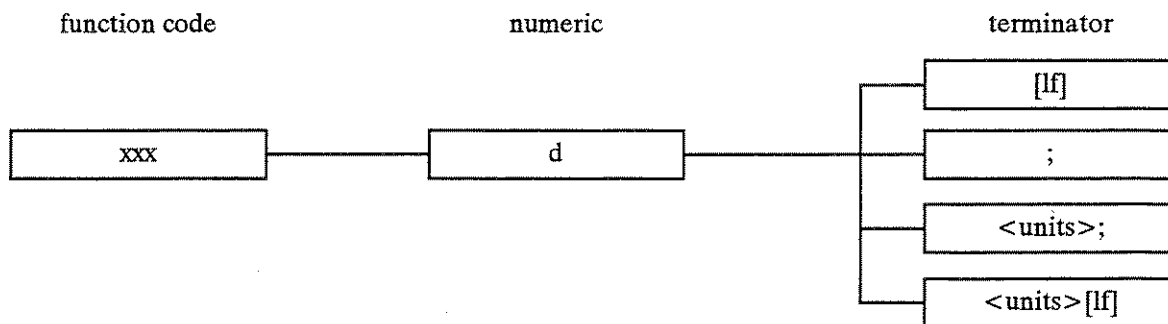

where: d = Variable length parameter, including sign, decimal point, and exponent, if desired. The general format is $\pm D.DDDDE\pm DD$. Resolution or range of d is explained under the particular command description. When the value of d does not correspond to the function's resolution or range, d will be rounded and assigned the closest allowable value.

Example: "AF64;RL-10DB;SD0.5DB[lf]"

Set the averaging factor to 64 (AF64), set the reference level to -10 dB (RL-10 dB), and set the scale per division to 0.5 dB (SD0.5 dB).

Input syntax #4: function code followed by a string of bytes or characters

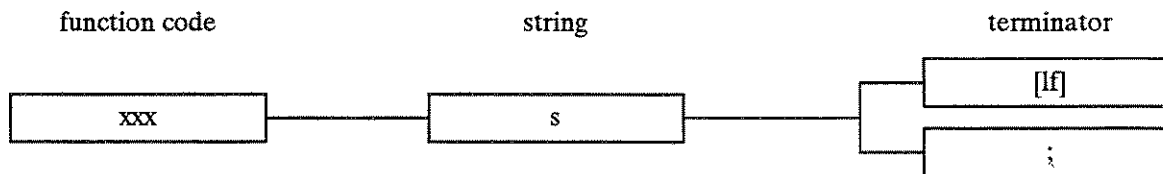

where: s = An ASCII string of characters or a sequence of 8-bit binary bytes, the length of which is unique to the particular function and is explained under the command description.

Example: WK1 TEST1;WT PASSBAND INSERTION LOSS[lf]"

Write softkey 1 with the label "TEST1" (WK1 TEST1), and write a title onto the CRT which says "PASSBAND INSERTION LOSS" (WT PASSBAND INSERTION LOSS).

Valid characters

Programming commands may be sent as upper or lower case ASCII characters. Spaces, unnecessary signs (+, -), leading zeros, carriage returns ([cr]) and unnecessary terminators are ignored by the analyzer. The parity bit (the eighth bit, MSB) of all ASCII coded characters will be ignored.

Any alphanumeric sequence which is not a recognized HP 8757D/E command will be noted on the CRT in the active entry area as "UNKNOWN CMD-" followed by the last one or two characters received by the analyzer over HP-IB. The analyzer will not lock out further HP-IB traffic, and will execute any subsequent valid command. Further, a syntax error service request (SRQ) will be output if that SRQ bit has been enabled in the request mask (see "Service Request" and "Status Byte"). If there are many errors in the alphanumeric sequence, only the last error is displayed in the active function area.

Programming data

See table 1 for HP-IB programming commands which control the analyzer.

Commands associated with the C detector are valid only for the HP 8757D Option 001. If a command associated with the C detector is sent to a standard HP 8757D (not Option 001) or an HP 8757E, it will be treated as an unknown command.

Commands associated with the internal power calibrator are valid only for the HP 8757D Option 002. If a command associated with the internal power calibrator is sent to an HP 8757D without option 002 or an HP 8757E, it will be treated as an unknown command.

Instrument preset

A self-test is first performed when the [PRESET] key is pressed or when the IP command is received by the analyzer. This is followed by presetting the analyzer and the instruments connected to the 8757 SYSTEM INTERFACE. All functions are turned off, then the following is set:

HP 8757D/E:

Channels 1 and 2 on.

- Measure power A on channel 1.
- Measure power B on channel 2.
- Measure power C² (or B) on channel 3¹.
- Measure power R on channel 4¹.
- Display measurement data in log magnitude format.
- Scale = 20 dB/division.
- Reference level 0 dB for all channels.
- Reference level step size = 20 dB.
- Averaging off.
- Averaging factor = 8.
- Cursor off.
- All labels on.
- Channel 1 as the active channel.
- Modulation drive on.
- Number of points = 401.
- Detector mode set for AC detection.
- Smoothing set for 5.0% of span (off).
- Cursor format = log magnitude.
- Search value = -3 dB¹.
- Adaptive normalization¹ off.
- Temperature compensation on.
- Repeat autozero off.
- Detector frequency offset³ off, start and stop = 50 MHz.
- Detector amplitude offset set to 0⁴.

SOURCE:

(connected to the 8757 SYSTEM INTERFACE)

- Instrument preset.
- Sweep time set to 200 ms.
- HP 8350B square wave modulation on.
- HP 8340/41 SHIFT PULSE on; RF Output on.
- HP 8360 scalar modulation on; RF Output on; analyzer mode.

PLOTTER:

(connected to the 8757 SYSTEM INTERFACE)

- Abort plot if in progress.
- P1 and P2 scaling points unchanged.
- Selection of plotter pens unchanged.

PRINTER:

(connected to the 8757 SYSTEM INTERFACE)

- Abort plot if in progress.

1. HP 8757D only.
2. HP 8757D Option 001 only.
3. HP 8757D with HP 85037 series precision detector only.
4. For the HP 8757E, the detector amplitude offset is not changed at PRESET.

DISK DRIVE:¹

(connected to the 8757 SYSTEM INTERFACE)

- Aborts any data transfers in progress.
- Unit number unchanged.
- Volume number unchanged.
- ASCII or binary mode unchanged.

The following analyzer conditions are not changed during a PRESET (IP) command execution:

- Reference position.
- Trace memory.
- Save/Recall registers.
- HP-IB addresses.
- Request mask.
- Limit lines¹.
- Title.
- User-defined plot.
- 8757 SYSTEM INTERFACE bus control on/off.
- Repeat autozero timer.
- Display intensity¹.
- Display colors¹.
- Plot buffer.

Passthrough

Programming commands and data may be sent to Hewlett-Packard instruments connected to the 8757 SYSTEM INTERFACE and the analyzer CRT. This is accomplished by first sending the PASSTHROUGH command (PTd), where d is the decimal address of the device being addressed. Subsequent addressing of the 8757 SYSTEM INTERFACE address will pass through commands to the selected device. The PTd command may be sent at any time. The default addresses for PASSTHROUGH commands are as follows:

HP 8757D/E Analyzer	16 decimal
8757 SYSTEM INTERFACE	17 decimal
HP 8757D/E CRT	15 decimal
Hewlett-Packard Source	19 decimal
Hewlett-Packard Plotter	05 decimal
Hewlett-Packard Printer	01 decimal
Hewlett-Packard Disk Drive	00 decimal

The following section explains how to pass through commands to instruments connected to the 8757 SYSTEM INTERFACE and the analyzer CRT.

8757 SYSTEM INTERFACE

This rear panel connector is physically similar to the HP-IB port, but is specifically used to control the following instruments:

Sources

- HP 8350B Sweeper
- HP 8340B Synthesized Sweeper
- HP 8341B Synthesized Sweeper
- HP 8360 Series Synthesized Sweeper

Plotters

- HP 7470A Two-pen Plotter
- HP 7475A Six-pen Plotter
- HP 7550A/B Eight-pen Plotter

Printers

- HP 2225A ThinkJet Printer
- HP 3630A PaintJet Printer
- HP 2227B QuietJet Plus Printer

Disk Drives

- HP 9122 Dual 3.5 in. Disk Drive

The transfer of commands and data is performed by first sending a PASSTHROUGH command (PTd) to the analyzer, where d is the decimal address of the desired device. Subsequent addressing of the 8757 SYSTEM INTERFACE will pass through commands to the instrument selected.

The address of the 8757 SYSTEM INTERFACE is determined by complementing the least significant bit of the current analyzer address. For example, since the analyzer default address is 16 decimal (10000 binary), the default 8757 SYSTEM INTERFACE address is 17 decimal (10001 binary). As another example, if the analyzer address is set to 7 decimal (111 binary), then the 8757 SYSTEM INTERFACE address becomes 6 decimal (110 binary).

This example shows how to pass through commands to the source, with address 19 decimal, using the analyzer default address (16 decimal):

1. Address device 16 (the HP-IB port on the analyzer) and send the command "PT19;"
2. Address device 17 (the 8757 SYSTEM INTERFACE) and send commands to the source.
3. Address device 16. This returns the analyzer to its normal HP-IB operation.

This example shows how to pass through commands to the plotter, with address 05 decimal, using the analyzer default address (16 decimal):

1. Address device 16 (the HP-IB port on the analyzer) and send the command "PT05;"
2. Address device 17 (the 8757 SYSTEM INTERFACE) and send commands to the plotter.
3. Address device 16. This returns the analyzer to its normal HP-IB operation.

CRT graphics

The CRT screen of the analyzer may be used as if it were an external HP-IB graphics plotter. By defining the analyzer CRT as the plot device used by the computer, the operator may pass through graphics commands which will plot graphics on the CRT.

The graphics commands are mostly a subset of the Hewlett-Packard Graphics Language (HP-GL), shown in table 4. The analyzer graphics characters used for labeling are shown in table 5, "HP 8757D/E Modified ASCII Code Conversion Table". These modified ASCII characters are available only when explicitly using the (LB) command; many desktop computer plotter commands use different character sets.

The address of the CRT is the analyzer address minus 1. The default address of the analyzer is 16 decimal, therefore the default address of the CRT is 15 decimal.

This example shows how to pass through commands to the CRT, with address 15 decimal, using the analyzer default address (16 decimal):

1. Address device 16 (the HP-IB port of the analyzer) and send the command "PT15;"
2. Address device 17 (the 8757 SYSTEM INTERFACE) and send graphics commands to the CRT.
3. Address device 16. This returns the analyzer to its normal HP-IB operation.

Output data

The analyzer has several output modes that allow you to learn or interrogate the instrument state and to output data. The following output modes are available:

- Learn String
- Interrogate Function
- Status
- Error
- Data
- Identity

The program codes and syntax to enable each function are shown in table 3.

Learn string

Selected with the OL program code, the analyzer outputs a learn string of 300 bytes in length (150 bytes for the HP 8757E). This binary data string completely describes the present instrument state (excluding the storage registers, trace memory, title, limit line data, and source settings) of the analyzer. This information is packed and encoded for minimal storage requirements, thereby making data analysis difficult. When stored in an ASCII character data string, the learn string can later be input to the analyzer to restore that instrument state by using the INPUT LEARN STRING command.

Interrogate function

The interrogate function is selected with the OP program code and followed immediately by the program code for the function to be interrogated. The analyzer will output the present value for the function that was selected to be interrogated. The units of the output value will be the same as the units available for setting the value, if it can be set. The functions valid for interrogation are: AF, BW, DA, DB, DC, DR, DTSTR, DTSTPx, DS, FD, NS, OD, ON, RL, RP, SD, SL, SO, SP, SR, SS, and ST.

Status

Selected with the OS program code, the analyzer will output 2 sequential 8-bit bytes giving the present instrument status. The first status byte is equivalent to the status byte of the serial poll; the second status byte is an extended status byte which provides additional information. See table 6 for a description of each status byte. The status bytes are cleared upon execution of either a serial poll, device clear (DCL), selective device clear (SDC), PRESET, or sending the CS or OS commands.

Error

Selected with the OE1 or OE2 program codes, the analyzer will output one 8-bit byte giving the present status of display channels 1 or 2, respectively. This can be used with the HP 8757D to determine which channel has failed the specified limit test, if limit lines were enabled.

Data

The analyzer outputs data from the designated display channel in one of four formats: ASCII formatted data, Extended ASCII formatted data, binary formatted data, and extended binary formatted data.¹ The two ASCII formats are the more general purpose formats and are the easiest to interpret the output values. Binary or extended binary formatted data provides the fastest data transfer rates and is usually the choice when transfer speed is a major concern. The data format is selected by using the FDx commands. The data format must be selected before a data transfer is attempted.

Identity

Selected with the OI program code, the analyzer will output a message which identifies it from other scalar network analyzers. Both the model number and the software revision are provided. This is helpful in system applications where software is written to run on more than one scalar network analyzer.

Trigger

The HP 8757D/E does not respond to the group execute trigger (GET) message.

Clear

The device clear (DCL) and selective device clear (SDC) messages clear all status bytes, the request mask, the HP-IB of the analyzer, and the 8757 SYSTEM INTERFACE.

Remote/Local

The analyzer goes to remote when the remote enable (REN) line on the interface is low (true) and it receives its listen address. In remote, all front panel functions are disabled except the LINE switch and the [LOCAL] key. The [LOCAL] key can be disabled via the LOCAL LOCKOUT (LLO) command. The state of the REN line is also sensed by the 8757 SYSTEM INTERFACE. An instrument on the 8757 SYSTEM INTERFACE designated as the pass through instrument (with the PTd command) is placed in remote or local depending on the state of the REN line. When the analyzer is placed in local lockout, the HP-IB source is also placed in local lockout.

The analyzer goes to local when it receives the GO TO LOCAL (GTL) command or when the REN line goes high (false). It will also return to local when the [LOCAL] key is pressed unless the LOCAL LOCKOUT (LLO) command has been executed.

Service request

The analyzer can initiate a service request (SRQ) whenever one of the following conditions exist:

- HP-IB command syntax error.
- End of operation (sweep or plot completed).
- Self-test failed.
- Any front panel key pressed.
- Numeric entry completed (HP-IB or front panel).
- Softkey only pressed.
- Battery voltage low.
- Rotary knob activity.
- Requested action not possible.
- Limit test failed.¹
- Operation failure¹ (power calibration failed).

For further information, execute a serial poll or the OUTPUT STATUS (OS) command. A serial poll operation consists of sending the analyzer its talk address, sending the SERIAL POLL ENABLE (SPE) command, reading the status byte on the bus, and sending the SERIAL POLL DISABLE (SPD) command. The SRQ is cleared only by executing either a serial poll, device clear (DCL), selective device clear (SDC), PRESET, or sending the CS or OS commands.

The request mask function (RMd) is used to specify a particular set of conditions for initiating a service request (SRQ). The mask value is determined by summing the decimal values of each selected function or condition that is desired. If a bit in the request mask is set to zero, that bit in the status byte will be masked and an SRQ cannot be initiated. For example, the command (RM41) indicates an SRQ can be initiated by the functions of bits 0, 3, and 5. The default value of the request mask at power-on is 00000000 or 0 decimal (no SRQ's are initiated).

1. HP 8757D only

Status byte

The HP 8757D/E responds to a serial poll by sending the status byte (#1). Both the status byte (#1) and the extended status byte (#2) are obtained by sending the OUTPUT STATUS (OS) command and by immediately reading both byte values, respectively. The status bytes of the analyzer are described in table 7.

When bit 6 (request service) of the status byte (#1) is true (one), an SRQ has occurred. See "Service Request" for the conditions causing a service request. Bit number 2 of the status byte (#1) indicates whether a change has occurred in the extended status byte (#2). If bit number 2 is true, then the extended status byte (#2) should be accessed via the OUTPUT STATUS (OS) command to determine the cause of the status change. All other bits (7, 5, 4, 3, 1, 0) of the status byte (#1) indicate the present status of the noted function. The bits are true (one) only if the associated function or condition is true.

Parallel poll

The HP 8757D/E does not respond to a parallel poll.

Controller capabilities

The HP 8757D/E does not have the ability to take or pass control.

Abort

The HP 8757D/E responds to the ABORT message (interface clear line, IFC true) by stopping all listener or talker functions.

Self-test

A self-test is performed at power-up and whenever the instrument PRESET (IP) command is received by the analyzer. This self-test routine includes a brief but thorough check that key parts of the instrument are functioning. At the conclusion of the self-test, the analyzer will be placed in its PRESET condition. The operator can check the outcome of the self-test by reading bit 0 of the extended status byte (#2) or by checking the front panel of the analyzer. For details on checking the front panel after the self-test, refer to the *Operating Reference*.

Address assignment information

The HP-IB address for the analyzer is set at the factory to decimal 16. The current address may be determined by pressing the [LOCAL] key on the front panel, then selecting the [8757] softkey, and observing the active entry area of the CRT. It may be changed, if desired, by entering the digits, range 00 to 29 decimal, followed by [ENT], using the keypad. Avoid the use of address 21 (most HP-IB controllers use this address) and any address used on the 8757 SYSTEM INTERFACE (analyzer CRT, source, plotter, printer, disk drive).

The new address is retained in non-volatile memory until changed by the operator. However, should battery power to the non-volatile memory be interrupted, the HP-IB address will default to 16 decimal.

The default addresses associated with the analyzer are listed in "Passthrough".

Secure frequency mode

The BL1 programming code blanks the frequency labels of the analyzer and source, and places the HP 8757D/E in secure frequency mode. Once in secure frequency mode, you cannot restore frequency labels for the existing configuration. Frequency labels can be restored with a PRESET (IP) command, however your frequency settings will be reset. Do not confuse this programming code with the BL5 programming code which blanks the entire screen and may be restored.

Table 1. Function Select Commands (1 of 7)

Action	HP-IB Command	Syntax	Description
Channel Selection	C1	1	Channel 1 on and the active channel.
	C2	1	Channel 2 on and the active channel.
	C3	1	Channel 3 on and the active channel. ¹
	C4	1	Channel 4 on and the active channel. ¹
	C0	1	Turns the currently active channel off.
Measure Power/Voltage	IA	1	Input A absolute power measurement.
	IB	1	Input B absolute power measurement.
	IC	1	Input C absolute power measurement. ²
	IR	1	Input R absolute power measurement.
	IX	1	External ADC Input ("AUX") voltage measurement.
Measure Ratio	AB	1	A/B ratio measurement.
	AC	1	A/C ratio measurement. ²
	AR	1	A/R ratio measurement.
	BA	1	B/A ratio measurement.
	BC	1	B/C ratio measurement. ²
	BR	1	B/R ratio measurement.
	CA	1	C/A ratio measurement. ²
	CB	1	C/B ratio measurement. ²
	CR	1	C/R ratio measurement. ²
	R1	1	R/A ratio measurement.
	R2	1	R/B ratio measurement.
	R3	1	R/C ratio measurement. ²
Display Trace Data	ME	1	Display measurement data.
	MY	1	Display memory data.
	M- or MN	1	Display normalized data (measurement - memory).
	DHm	2	Display hold on/off of the active trace.
	SM	1	Store measurement data into memory.
	SN	1	Store normalized data (measurement - memory) into memory.
	DS0	1	Display trace data in a log magnitude format.
DS1	1	Display trace data in a Standing Wave Ratio (SWR) format.	
Scale	AS	1	Autoscale the trace on the CRT.
	SDd	3	Set scale per division to d; where d is ⁴ for dB, dBm: 20, 10, 5, 2, 1, 0.5, 0.2, or 0.1 for SWR: 10, 4, 2, 1, 0.4, 0.2, 0.1, 0.04, or 0.02 for Volts: 5, 2.5, 1, 0.5, 0.25, 0.1, 0.05, or 0.025
Reference Level	MR	1	Marker = Reference Level. Moves the cursor (or active marker if no cursor) and trace to the reference line.
	RLd	3	Set Reference Level to d; d must be in the range of: ratio measurement ³ : +90 to -90 dB normalized measurement ³ : +90 to -90 dB power measurement ³ : +20 to -70 dBm SWR measurement: 1.0 to 37.0 SWR voltage measurement: +10 to -10V normalized voltage measurement: +20 to -20V
	STd	3	Set Reference Level Step size to d; where d is for dB, dBm: 0 to 60 dB for SWR: 1 to 37 SWR for Volts: 0 to 10V
Reference Position	RPq	2	Set Reference Position; q has a value from 0 to 8 corresponding to the major horizontal graticule lines: 8 = top graticule line 4 = center graticule line 0 = bottom graticule line

1. HP 8757D only.
2. HP 8757D Option 001 only (C detector).
3. When utilizing a detector offset, the reference level range is offset by the offset amount. HP 8757D only.
4. For HP 8757D, scale per division is variable.

Table 1. Function Select Commands (2 of 7)

Action	HP-IB Command	Syntax	Description
Cursor	CUm	2	Cursor on/off.
	CDm	2	Cursor Delta on/off.
	CX	1	Cursor to maximum for the active channel.
	CN	1	Cursor to minimum for the active channel.
	SSd ¹	3	Set cursor search value to amplitude value of d; d must be in the range of: ratio measurement: +60 to -60 dB normalized measurement: +60 to -60 dB power measurement: +60 to -60 dBm ⁴ Maximum resolution of d is 0.01 dB(m). Cursor search functions are not allowed in SWR or Voltage display modes.
	SL ¹	1	Cursor Search Left for the search value. Cursor will search left to the first frequency point (or interpolated point which equals the search value). If the value cannot be found, the message "SEARCH VALUE NOT FOUND" will appear in the ACTIVE ENTRY AREA.
SR ¹	1	Cursor Search Right for the search value. Cursor will search right to the first frequency point (or interpolated point which equals the search value). If the value cannot be found, the message "SEARCH VALUE NOT FOUND" will appear in the ACTIVE ENTRY AREA.	
BW ¹	1	Cursor search for bandwidth representing the search value. If the value cannot be found, the message "BANDWIDTH VALUE NOT FOUND" will appear in the ACTIVE ENTRY AREA.	
Cursor Format	FR0	1	Cursor format logarithmic (dB or dBm). ²
	FR1	1	Cursor format SWR.
Averaging	A0	1	Averaging off.
	AFd	3	Averaging on and factor set to d; d is 0 (enables previous factor), 1, 2, 4, 8, 16, 32, 64, 128, or 256.
	RS	1	Restart averaging process on the next sweep.
DC Detector Zero	MZ	1	Manual zero of the DC detectors. The operator must turn the source RF power off before sending this command.
	AZm	2	Auto Zero Repeat on/off of the DC detectors. The source RF power is automatically turned off at an interval determined by the Repeat Auto Zero Timer and the DC zero is performed each time. ³
	AZ2	1	Auto Zero of the DC detectors. The source RF power is automatically turned off and the DC zero is performed once. ³
	ZTd	3	Repeat Auto Zero Timer interval set to d; d is a decimal integer from 1 to 60 minutes.
Smoothing	S0d	3	Set Smoothing to d % of span; d must be in the range of 0.0 to 20.0%, with a maximum resolution of 0.1%. When d is set to 0, smoothing is off.
Step	UP	1	Step up; increment the active parameter.
	DN	1	Step down; decrement the active parameter.

1. HP 8757D only.
2. Available only if display trace data is in log magnitude format (see DS0).
3. This command is valid only when the operator is using a source which is connected to the 8757 SYSTEM INTERFACE.
4. When utilizing a detector offset, the search range is offset by the offset amount. HP 8757D only.

Table 1. Function Select Commands (3 of 7)

Action	HP-IB Command	Syntax	Description																														
Plot	BFm	2	Plotter buffer on/off.																														
	PA	1	Plot All; plots entire display (except user graphics) on an external plotter.																														
	P1	1	Plot channel 1 trace.																														
	P2	1	Plot channel 2 trace.																														
	P3	1	Plot channel 3 trace. ¹																														
	P4	1	Plot channel 4 trace. ¹																														
	PC	1	Plot only labels on a external plotter.																														
	PG	1	Plot only the grid on an external plotter.																														
	SUd	3	Specify custom plot; d is a decimal integer from 0 to 255 representing one byte. Each bit of this byte specifies what is to be plotted. If a bit is set to 1, that item will be plotted, else it will not be plotted.																														
				<table border="0"> <thead> <tr> <th>bit</th> <th>decimal value</th> <th>action</th> <th>bit#</th> <th>decimal value</th> <th>action</th> </tr> </thead> <tbody> <tr> <td>0 (LSB)</td> <td>1</td> <td>Scale Trace (P1 and P2 define grid size)</td> <td>4</td> <td>16</td> <td>Trace 4¹</td> </tr> <tr> <td>1</td> <td>2</td> <td>Trace 1</td> <td>5</td> <td>32</td> <td>Grid</td> </tr> <tr> <td>2</td> <td>4</td> <td>Trace 2</td> <td>6</td> <td>64</td> <td>Mode Labels</td> </tr> <tr> <td>3</td> <td>8</td> <td>Trace 3¹</td> <td>7 (MSB)</td> <td>128</td> <td>Frequency Labels</td> </tr> </tbody> </table>	bit	decimal value	action	bit#	decimal value	action	0 (LSB)	1	Scale Trace (P1 and P2 define grid size)	4	16	Trace 4 ¹	1	2	Trace 1	5	32	Grid	2	4	Trace 2	6	64	Mode Labels	3	8	Trace 3 ¹	7 (MSB)	128
bit	decimal value	action	bit#	decimal value	action																												
0 (LSB)	1	Scale Trace (P1 and P2 define grid size)	4	16	Trace 4 ¹																												
1	2	Trace 1	5	32	Grid																												
2	4	Trace 2	6	64	Mode Labels																												
3	8	Trace 3 ¹	7 (MSB)	128	Frequency Labels																												
	PD	1	Plot custom plot on an external plotter																														
Print	PR1	1	Print entire graphics display (except user graphics) on external graphics printer.																														
	PR2	1	Print tabular display data in monochrome.																														
	PR3	1	Print tabular marker/cursor data on external printer.																														
	PR4	1	Print all to color printer, except softkeys and CRT graphics.																														
Limit Lines ²	LE	1	Erase limit lines for active channel.																														
	LPs	4	Limit is single point specified by s. The string s includes the segment number (1 to 12), the x-axis value, the upper limit value, and the lower limit value in the following format: "LP [seg. no.], [x-value] [x-units], [upper limit] [y-units], [lower limit] [y-units];" where [x-value] is a frequency or value determined by the start/stop labels. [x-units] is "GZ" for GHz, "MZ" for MHz, "KZ" for kHz, "HZ" for Hz, or blank for no units. [y-units] is "DB" for dB/dbm, "SWR" for SWR, or "V" for volts. Entering no value for an upper or lower limit value means do not test this limit. An example: "LP 1, 2.5 GZ, 1.5 DB, -1 DB;"																														
	LFs	4	Limit is a flat line specified by s. The string s includes the segment number (1 to 12), the start x-axis value, upper limit value, lower limit value, and stop x-axis value in the following format: "LF [seg. no.], [x-start] [x-units], [upper limit] [y-units], [lower limit] [y-units], [x-stop] [x-units];" where [x-value], [x-units], and [y-units], are described above. An example: "LF 2, 750 MZ, -30 DB, -32 DB, 850 MZ;"																														
	LSs	4	Limit is sloped line specified by s. The string s includes the segment number (1 to 12), the start x-axis value, start upper limit value, start lower limit value, the stop x-axis value, the stop upper limit value and the stop lower limit value in the following format: "LS [seg. no.], [x-start] [x-units], [upper limit] [y-units], [lower limit] [y-units], [x-stop] [x-units], [upper limit] [y-units], [lower limit] [y-units];" where [x-value], [x-units], and [y-units] are described above. An example: "LS 4, 2 GZ, -3 DB, -4 DB, 3 GZ, 0 DB, -1 DB;"																														
	LTm	2	Limit line test on/off. If on, limit test status is designated by the CRT PASS/FAIL message and status bytes.																														
		LL	1	Store lower limit line into memory.																													
	LU	1	Store upper limit line into memory.																														
1. HP 8757D only. 2. Limit line functions valid only for channels 1 or 2. 8757D only.																																	

Table 1. Function Select Commands (4 of 7)

Action	HP-IB Command	Syntax	Description
Graticule Start/Stop Labels	FAs	4	Start value for labeling x-axis graticule and entry of limit lines when System Interface control is off or no source is connected to the 8757 SYSTEM INTERFACE. s is a string in the following format: "FA [value] [x-units];" where [x-units] is "GZ" for GHz, "MZ" for MHz, "KZ" for kHz, "HZ" for Hz, or blank for no units. An example: "FA 6.55 GZ;"
	FBs	4	Stop value for labeling x-axis graticule and entry of limit lines when System Interface control is off or no source is connected to the 8757 SYSTEM INTERFACE. s is a string in the following format: "FB [value] [x-units];" where [x-units] is described above.
Number of Trace Points	SPd	3	Set the Number of Points displayed on the horizontal axis to d; d is 101, 201, 401, 801 ¹ , or 1601 ¹ . If source is connected to the 8757 SYSTEM INTERFACE, the sweep time may change.
Power Calibration ^{3,4}	PWRA	1	Execute a detector A power calibration.
	PWRB	1	Execute a detector B power calibration.
	PWRC ²	1	Execute a detector C power calibration.
	PWRR	1	Execute a detector R power calibration.
Measure Detector Offset ^{3,4}	DOAd	3	Measure detector A amplitude offset. Power calibrator output power set to d. d must be in the range of +20 to -50 dBm (1 dB resolution). For example: "DOA -10 DB;"
	DOBd	3	Measure detector B amplitude offset. Power calibrator output power set to d. d must be in the range of +20 to -50 dBm (1 dB resolution).
	DOCd ²	3	Measure detector C amplitude offset. Power calibrator output power set to d. d must be in the range of +20 to -50 dBm (1 dB resolution).
	DORd	3	Measure detector R amplitude offset. Power calibrator output power set to d. d must be in the range of +20 to -50 dBm (1 dB resolution).
	EO	1	Enter the measured detector offset into the analyzer's detector offset memory. This command must immediately follow the DOXd or OPDO command.
	OPDO	1	Output the measured detector offset. Output data format: [±D.DDDDE±DD][lf]. This command must immediately follow the DOXd or EO command.
Detector Amplitude Offsets	DAd	3	Set Detector A offset to d; d must be in the range of +60 to -60 dB with a maximum resolution of 0.001 dB. ⁵
	DBd	3	Set Detector B offset to d; d must be in the range of +60 to -60 dB with a maximum resolution of 0.001 dB. ⁵
	DCd	3	Set Detector C offset to d; d must be in the range of +60 to -60 dB with a maximum resolution of 0.001 dB. ^{2,5}
	DRd	3	Set Detector R offset to d; d must be in the range of +60 to -60 dB with a maximum resolution of 0.001 dB. ⁵
External Detector Calibration	XAd	3	Enter external cal value for the specific detector input. d is the code number in the format of [DDDDDD;], read from the front panel after performing a calibration.
	XBd	3	
	XCd ²	3	
	XRd	3	
Detector Mode	DM0	1	Set Detector mode of all inputs for DC detection.
	DM1	1	Set Detector mode for all inputs for AC detection.
<ol style="list-style-type: none"> 1. HP 8757D only. 2. HP 8757D Option 001 only (C detector). 3. HP 8757D Option 002 only. 4. The appropriate detector must be connected to the HP 8757D Option 002 power calibrator before executing this command. 5. Resolution for HP 8757E is 0.01 dB. 			

Table 1. Function Select Commands (5 of 7)

Action	HP-IB Command	Syntax	Description
Detector Frequency ⁵	DTSTRAs	4	Enters start frequency for detector A. s is a string in the following format: "DTSTRA [value] [x-units];" where [x-units] is "GZ" for GHz, "MZ" for MHz, "KZ" for kHz, or "HZ" for Hz. An example: "DTSTRA 19.65 GZ;"
	DTSTRBs	4	Enters start frequency for detector B. See definition for s above.
	DTSTRCs ²	4	Enters start frequency for detector C. See definition for s above.
	DTSTRRs	4	Enters start frequency for detector R. See definition for s above.
	DTSTPAs	4	Enters stop frequency for detector A. s is a string in the following format: "DTSTRA [value] [x-units];" where [x-units] is "GZ" for GHz, "MZ" for MHz, "KZ" for kHz, or "HZ" for Hz. An example: "DTSTRA 10.25 GZ;"
	DTSTPBs	4	Enters stop frequency for detector B. See definition for s above.
	DTSTPCs ²	4	Enters stop frequency for detector C. See definition for s above.
	DTSTPRs	4	Enters stop frequency for detector R. See definition for s above.
	FTAm	2	Detector A frequency on/off.
	FTBm	2	Detector B frequency on/off.
	FTCm ²	2	Detector C frequency on/off.
	FTRm	2	Detector R frequency on/off.
	OPDTSTRA	1	Outputs detector A start frequency.
	OPDTSTRB	1	Outputs detector B start frequency.
	OPDTSTRC ²	1	Outputs detector C start frequency.
	OPDTSTRR	1	Outputs detector R start frequency.
OPDTSTPA	1	Outputs detector A stop frequency.	
OPDTSTPB	1	Outputs detector B stop frequency.	
OPDTSTPC ²	1	Outputs detector C stop frequency.	
OPDTSTPR	1	Outputs detector R stop frequency.	
Adaptive Normalization	ANm	2	Adaptive Normalization on/off ¹ .
System Calibration	CL	1	Perform system configuration calibration of the detectors and channels.
	TCm	2	Continuous temperature compensation on/off.
	CTm	2	Auto System Calibration on/off. Performs a system calibration at an interval of every five minutes.
Sweep Mode	NSm	2	Non-standard sweep on/off. Allows the HP 8757D/E to track any sweep ramp in the range of 0 to 10 V, increasing in sweep voltage.
	CWm	2	CW mode (single point) on/off. ³
	Msm	2	Manual sweep mode on/off. ³
	PBm	2	System Interface control on/off.
	FSm	2	Step sweep mode on/off. ^{3,4}
Modulation	MDm	2	Rear panel square-wave modulation output on/off.

1. HP 8757D only.
 2. HP 8757D Option 001 only (C detector).
 3. If source is connected to the 8757 SYSTEM INTERFACE and the interface control is on, the source is also set to this mode.
 4. HP 8340, HP 8341, and HP 8360 only with 8757 SYSTEM INTERFACE connected and active.
 5. HP 8757D with HP 85037 series precision detector only.

Table 1. Function Select Commands (6 of 7)

Action	HP-IB Command	Syntax	Description
Save/Recall Registers	SVn	2	Save front panel settings in register n; n from 1 to 9. Note that registers 1 to 4 also retain title, channels 1 and 2 limit line information, and channels 1 and 2 trace memories.
	RCn	2	Recall front panel settings from register n; n from 1 to 9.
	ER0	1	Erase all save/recall registers.
Instrument Preset	IP	1	Presets the HP 8757D/E and the instruments connected to the 8757 SYSTEM INTERFACE.
Front Panel Menus/ Softkeys	MU0	1	Display the Measurement Menu.
	MU1	1	Display the Display Menu.
	MU2	1	Display the Scale Menu.
	MU3	1	Display the Reference Menu.
	MU4	1	Display the Cursor Menu.
	MU5	1	Display the Average Menu.
	MU6	1	Display the Calibration Menu.
	MU7	1	Display the Special Menu.
	MU8	1	Display the System Menu.
SKq	1	Select Softkey q; q is from 1 to 8. Equivalent to manually pressing the softkey.	
		2	
Display/ Color Control ¹	BTNd	3	Adjust the overall display brightness. Values for d can be defined by the user. See the Operating Reference for more information.
	DEC	1	Set default colors.
	MOC	1	Set monochrome mode.
	CCq	2	Selects channel q as the feature affected by color selection commands found under CLx. Valid values for q are 1 to 4.
	CGL	1	Set labels color.
	CGN	1	Selects background as the feature affected by color selections. For example: "CGN; CLB;" sets the background to black. Note: Select the feature to be changed before selecting the color. Define custom colors with COT, COB, and COC. These commands are used like the color list commands. For example: "CGN; COB100;COC75;COT100" defines all three parameters of a feature's color.
	CGR	1	Set grid color.
	CGW	1	Set warning label color.
	CLx	1	Selects a color from the color list for the feature previously selected. x represents colors from the color list. Valid values for x are: W - White Y - Yellow S - Salmon B - Black L - Blue R - Red G - Green
	COBd	3	Custom color brightness, affects the feature last selected. d ranges from 0 to 100.
	COCd	3	Custom color adjust, affects the feature last selected. d ranges from 0 to 100.
	COTd	3	Custom tint adjust, affects the feature last selected. d ranges from 0 to 100.
1. HP 8757D only.			

Table 1. Function Select Commands (7 of 7)

Action	HP-IB Command	Syntax	Description
Disk Save/Recall ¹	DFA	1	The data sent after this command is stored in ASCII format. This is important for retrieving the data for use in another program.
	DFB	1	The data sent after this command is stored in fast binary format allowing quicker file access times.
	DFE	1	The data sent after this command is stored in extended binary format. This format provides a wider display range than the binary format. Refer to Format Data on page 15.
	DIAd	3	Sets the HP-IB address for the disk drive on the bus. The valid range for d is 0 to 29.
	DIUd	3	Selects active disk unit. For example: With an HP 9122, select unit 0 or unit 1. The valid range for d is 0 to 15.
	DIVd	3	For hard drives with multiple partitions. The valid range for d is 0 to 15.
	DLF	1	Deletes the last file selected from the disk or, if no filename was selected, the default file, FILE1, is deleted (if FILE1 existed on the disk).
	IND	1	Formats the disk in the disk unit last selected.
	LFx	1	Loads from disk the items selected by x. All information is recalled from the last file specified by the "TIFs" command. If no filename was selected, then the default file, FILE1, is recalled from disk (if FILE1 exists). Valid selections for x are: A - Load all information files from disk F - Measurement trace only C - CRT graphics only M - Memory trace only I - Instrument state only D - Data trace only H - Load all information files from disk, N - Display trace only hold display
	SFx	1	Stores to disk the items selected by x. All information is stored into the last file selected by the "TIFs" command. If no filename was selected, then the default file, FILE1, is overwritten. Valid selections for x are: A - Store all information files to disk M - Memory trace only C - CRT graphics only D - Data trace only I - Instrument state only N - Display trace only F - Measurement trace only
	TIFs	4	Defines the current active title for an existing or a new file. The string s can be up to eight characters in length and include only letters or numbers. For example: Select a file named SAMPLE with "TIFSAMPLE". Before storing to, loading from, or deleting files from disk, select a title.

1. HP 8757D only.

Table 2. HP-IB Only Functions (1 of 2)

Action	HP-IB Command	Syntax	Description
Display Blanking	BL0	1	No blanking; restore CRT to normal mode.
	BL1	1	Blank only the frequency labels (see <i>Secure frequency mode</i> , page 7).
	BL2	1	Blank all labels on the CRT.
	BL3	1	Blank only the active channel trace.
	BL4	1	Blank only the softkey labels.
	BL5	1	Blank all of the CRT except user graphics.
	BL6	1	Blank only the user title.
	BL7	1	Blank only the mode labels.
	BL8	1	Blank only the active entry area.
	BL9	1	Blank only the limit lines. ¹
	BLA	1	Blank all of the CRT except user graphics and softkeys.
BLB	1	Blank only the user CRT, graphics.	
Status Bytes	CS	1	Clear Status bytes #1 and #2.
	RMd	3	Set Request Mask of status byte #1 to d; d is decimal integer from 0 to 255.
Format Data	FD0	1	Format Data ASCII; all successive data transfers are made in ASCII format. Data is transferred in [\pm DD.DDD] format where D is an ASCII digit.
	FD2	1	Format Data Extended ASCII; all successive data transfers are made in an extended ASCII format. Data is transferred in [\pm DDD.DDD] format where D is an ASCII digit.
	FD1	1	Format Data Binary; all successive data transfers are made in a binary format. FD1 is for HP BASIC (MSB first); FD3 is for PC format files (LSB first). Two bytes are transferred, the value of which is scaled by the limits shown below in Table 2a.
	FD3	1	
	FD4 ¹	1	Format Data Extended Binary; all successive data transfers are made in an extended binary format. Extended binary format extends the range limits beyond the binary format (for ratio, normalized ratio, power and normalized power measurements only). The range extension is a function of the analyzer's detector amplitude offset settings. FD4 is for HP BASIC (MSB first); FD5 is for PC format files (LSB first). Two bytes are transferred, the value of which is scaled and offset as shown below.
FD5 ¹	1		

Table 2a. Display Range Limits and Scale Factor, Binary Data Transfer

Display Range	Decimal Value of Binary Data	Ratio Meas	Normalized Ratio Meas	Power Meas	Normalized Power Meas	SWR Meas	Voltage Meas	Normalized Voltage Meas
Lower Limit (V0)	0	-90 dB	-180 dB	-70 dBm	-90 dB	1.0	-11.25 V	-22.5 V
Upper Limit (V1)	32767	+90 dB	+180 dB	+20 dBm	+90 dB	37.0	+11.25 V	+22.5 V
Scale Factor (V1-V0)/32767		5.493E-3	1.099E-2	2.747E-3	5.493E-3	1.099E-3	6.867E-4	1.373E-3

Binary Data Transfer (FD1, FD3)

Binary data can be unscaled using the following equation:

$$\text{real value} = (\text{Decimal Value of Binary Data} \times \text{Scale Factor}) + V0$$

Binary data transfer example: Absolute power measurement, decimal value transferred for one data point = 21842. dBm value is calculated as follows:

$$\text{dBm} = [21842 \times 2.747E-3] + (-70) = -10.00 \text{ dBm}$$

Extended Binary Data Transfer (FD4, FD5)¹

Extended binary data can be unscaled using the following equation:

$$\text{real value} = (\text{Decimal Value of Binary Data} \times \text{Scale Factor}) + \text{Offset}$$

Based on the data which is transferred, the scale factor and offset value that is inserted into the above equation is obtained using HP-IB commands shown in Table 2B. The data which is transferred is a number in the following format: [\pm D.DDDDDDE \pm DD] [lf]

Table 2b. HP-IB Commands to Extract Scale Factor and Offset from the HP 8757D

Data Transferred via HP-IB	HP-IB Command to Extract Scale Factor	HP-IB Command to Extract Offset
Normalized data (measurement - memory) transferred via the ON command.	OPNS	OPON
Measurement data transferred via the OD command.	OPDS	OPOD
Memory data transferred via the OM command.	OPMS	OPOM

1. HP 8757D only.

Table 2. HP-IB Only Functions (2 of 2)

Action	HP-IB Command	Syntax	Description												
Pass Through Address	PTd	3	Set the Pass Through address of an instrument connected to the 8757 SYSTEM INTERFACE; d is a two digit ASCII integer which represents the HP-IB address of the instrument to be programmed.												
Cursor Position	SCd	3	Set Cursor position to d; d is a decimal integer which represents a horizontal position on the CRT with a range of values shown below: <table border="0" style="margin-left: 40px;"> <tr> <td style="text-align: center;"><u>No. of trace points</u></td> <td style="text-align: center;"><u>range of d</u></td> </tr> <tr> <td style="text-align: center;">101</td> <td style="text-align: center;">0 to 100</td> </tr> <tr> <td style="text-align: center;">201</td> <td style="text-align: center;">0 to 200</td> </tr> <tr> <td style="text-align: center;">401</td> <td style="text-align: center;">0 to 400</td> </tr> <tr> <td style="text-align: center;">801¹</td> <td style="text-align: center;">0 to 800</td> </tr> <tr> <td style="text-align: center;">1601¹</td> <td style="text-align: center;">0 to 1600</td> </tr> </table>	<u>No. of trace points</u>	<u>range of d</u>	101	0 to 100	201	0 to 200	401	0 to 400	801 ¹	0 to 800	1601 ¹	0 to 1600
<u>No. of trace points</u>	<u>range of d</u>														
101	0 to 100														
201	0 to 200														
401	0 to 400														
801 ¹	0 to 800														
1601 ¹	0 to 1600														
Control Outputs	OT1m OT2m	2 2	Rear panel control output #1 on/off. Rear panel control output #2 on/off.												
Sweep Mode	SW0 SW1 SW2 TSd	1 1 1 3	Non-swept mode. Sweep off; hold data on the CRT. Swept mode. Sweep on; continuously track sweep ramp voltage and update trace data on the CRT. Sweep Hold mode. Sweep off; hold HP-IB bus activity until completion of TSd number of sweeps. Take d Sweeps, then hold trace data on the CRT. The HP 8757D/E must be in the Non-Swept (SW0) or Sweep Hold (SW2) modes before executing. d is a decimal integer from 1 to 255. For certain operating modes, such as SWR trace mode, Alternate Sweep on, Averaging on, or Smoothing on, it is recommended that 2 successive sweeps be taken for accurate data.												
Learn String	ILs	4	Input learn string; s is string of 300 binary bytes (150 bytes for the HP 8757E) that were output by the output learn string command.												
Write Softkey Label	WKs	4	Write softkey label for a particular softkey. s is an ASCII string; the first character is the softkey number (range 1 to 8) followed by the label. The label can be sent in the following forms: one word label: “[ASCII label] [term]” two word label: “[ASCII label], [ASCII label] [term]” where [ASCII label] is ≤7 characters and [term] is a valid terminator.												
Write Title	WIs	4	Write Title to the CRT; s is an ASCII string of up to 50 characters.												
Write To Trace Memory	WMs	4	Write to the channel memory. Data is transferred from the computer to the channel memory of the analyzer. Several parameters must be properly set before the transfer is made: <ul style="list-style-type: none"> • data format must be set using the FDx command • the desired channel memory is selected by making that channel the active channel. • the number of points transferred must equal the present number of points/trace. 												

1. HP 8757D only.

Table 3. Output Modes (1 of 2)

Action	HP-IB Command	Description	Format
Output Learn String	OL	Outputs binary data string 300 bytes long (150 bytes for the HP 8757E) which completely describes the instrument state. Can be stored in an ASCII character string and later input to restore that instrument state.	HP 8757D: 300 [B] [EOI] HP 8757E: 150 [B] [EOI]
Output Interrogated Parameter Value	OPx	Outputs the present numeric value of the function selected. x is the function code to interrogate (AF, BW, DA, DB, DC, DR, DS, NS, OD, OM, ON, RL, RP, SD, SL, SO, SP, SR, SS, ST, DTSTRA, DTSTRB, DTSTRC ¹ , DTSTRR, DTSTPA, DTSTPB, DTSTPC, DTSTPR)	[±D.DDDDE±DD] [lf]
Output Cursor Value	OC	Outputs cursor or cursor Δ amplitude and horizontal position. Format set by the FDx, FRx, and DSx commands.	ASCII Data: [±DD.DDD,] [DDDD] [lf] Extended ASCII: [±DDD.DDD,] [DDDD] [lf] Binary and Extended Binary Data: [BB] [BB] [EOI]
Output Measurement Data	OD	Output measurement data; no. of data points is the same as the no. of points/trace. Format set by "FDx" command. With the OD command, data is returned in units of dB or dBm unless in SWR trace format (units are SWR). In general, whenever a measurement is defined (dBm, dB, SWR), one or more sweeps must be taken before the data is valid. Not valid for SWR trace mode.	ASCII Data: (n-1) [±DD.DDD,] [±DD.DDD] [lf] Extended ASCII: (n-1) [±DDD.DDD,] [±DDD.DDD] [lf] Binary and Extended Binary Data: n [BB] [EOI] n = no. of points per trace.
Output Memory Data	OM	Output memory data; no. of data points is the same as the no. of points/trace. Format set by "FDx" command.	ASCII Data: (n-1) [±DD.DDD,] [±DD.DDD] [lf] Extended ASCII: (n-1) [±DDD.DDD,] [±DDD.DDD] [lf] Binary and Extended Binary Data: n [BB] [EOI] n = no. of points per trace.
Output Normalized Data	ON	Output normalized data; (measurement—memory); no. of data points is the same as the no. of points/trace. Format set by "FDx" command.	ASCII Data: (n-1) [±DD.DDD,] [±DD.DDD] [lf] Extended ASCII: (n-1) [±DDD.DDD,] [±DDD.DDD] [lf] Binary Data: n [BB] [EOI] n = no. of points per trace.
Output CW Value	OV	Output CW value; Non-swept mode (SW0 or SW2) must be set. Format set by "FDx" command. Data is returned in dBm or dB, even if SWR trace format is used.	ASCII Data: [±DD.DDD] [lf] Extended ASCII: [±DDD.DDD] [lf] Binary and Extended Binary Data: n [BB] [EOI]

Table 3. Output Modes (2 of 2)

Action	HP-IB Command	Description	Format																											
Output Error Status	OE1 OE2	Outputs error status of display channel 1 or 2. One byte is output, where each bit indicates:	[B] [EOI]																											
		<table border="1"> <thead> <tr> <th>Bit#</th> <th>7</th> <th>6</th> <th>5</th> <th>4</th> <th>3</th> <th>2</th> <th>1</th> <th>0</th> </tr> </thead> <tbody> <tr> <td>Decimal Value</td> <td>128</td> <td>64</td> <td>32</td> <td>16</td> <td>8</td> <td>4</td> <td>2</td> <td>1</td> </tr> <tr> <td>Function</td> <td>N/A</td> <td>N/A</td> <td>N/A</td> <td>N/A</td> <td>N/A</td> <td>N/A</td> <td>N/A</td> <td>Out of Limits</td> </tr> </tbody> </table>		Bit#	7	6	5	4	3	2	1	0	Decimal Value	128	64	32	16	8	4	2	1	Function	N/A	N/A	N/A	N/A	N/A	N/A	N/A	Out of Limits
		Bit#		7	6	5	4	3	2	1	0																			
		Decimal Value		128	64	32	16	8	4	2	1																			
Function	N/A	N/A	N/A	N/A	N/A	N/A	N/A	Out of Limits																						
Output Keypcode	OK	Output keycode for the last front panel key pressed. Refer to table 8 for keycodes	[DD] [lf]																											
Output Knob Value	OR	Output Knob value; the value is between -32768 and +32767. It is reset to 0 after value output. Negative value = counterclockwise rotation, positive value = clockwise rotation.	[BB] [EOI]																											
Output Status Bytes	OS	Output 2 bytes, the Status Byte (#1) and the Extended Status Byte (#2). Both bytes are then cleared.	[BB] [EOI]																											
Output Identity	OI	Outputs the HP 8757D/E identity string and the firmware revision number xx.x (i.e., 05.0 for revision 5.0)	"8757D REVxx.x" [cr] [lf] or "8757E REVxx.x" [cr] [lf]																											
NOTES: D = ASCII digit B = 8-bit byte , = comma EOI = End or Identity HP-IB line true cr = carriage return lf = line feed																														

Table 4. CRT Graphics Commands (1 of 2)

HP-GL Subset	
Note: All Graphics Commands must be terminated with a semicolon ";" or a "[linefeed]" (the character [carriage return] is ignored).	
HP-IB Command	Command Description
DF	Default; sets monochrome default values. ("DI 1,0;SI 0.14,0.17;")
DI run, rise	Absolute Character Direction; run rise allowable values are: 1, 0 = 0 degrees (default) 0, 1 = 90 degrees -1, 0 = 180 degrees 0, -1 = 270 degrees
LB [text] [ETX]	Label text. Character set is shown in table 5, HP 8757D/E Modified ASCII Character Set. Before labeling text, move the pen to the appropriate (x,y) coordinate using the PU and PA commands. The text will be plotted with the lower left corner of the first character starting at the existing pen position. The pen stops at the lower left corner of the next character space.
OP	Output the current P1 and P2 positions. (P1 = 0,0; P2 = 2924, 2047). The graphics display units (GDU's) define the plotting area on the CRT. The coordinates of the full plotting area are (0,0) for lower left, (2924,2047) for upper right. The coordinates for the trace graticule are (214, 150) for lower left, (2500, 1814) for upper right.
PA x1, y1 (x2,y2, ..., xN, yN)	Plot Absolute; x and y are integers and are in Graphics Display Units (GDU's). Moves the pen to the specified (x,y) coordinates. Both the x and y coordinates must be specified. Any number of coordinate pairs can be specified when separated by commas. Use of the PD and PU commands determines whether a line is drawn or the pen is just moved. If an (x,y) coordinate is specified outside of the plotting area, only that portion of the line within the plotting area is drawn.
PD	Pen Down.
PU	Pen Up.
SI, w, h	Absolute Character Size; w = width; h = height. Values allowed are: 0.14, 0.17 Smallest size (Mode labels, softkey labels) 0.21, 0.25 (Active Entry Area) 0.28, 0.34 0.35, 0.42 Largest size
SP n	For monochrome display: select pen; n = 0 to 4; 0 Pen up (Beam off) 1 Bright Green 2 Half-Bright Green 3 Dim Green

Table 4. CRT Graphics Commands (2 of 2)

Non-HP-GL Commands			
The following HP-GL commands will be accepted but their functions are not implemented and no error will be noted: IM (Input SRQ Mask), IP (Input P1 and P2), IW (Input Window), OC (Output Current Position), OE (Output Error), PG (Output Page), SL (Character Slant), and SR (Size Relative for characters).			
	HP-IB Command	Command Description	
Erase Page	EPn	Erase Page n, where n = 1 to 8; if no n value is given, all pages are erased.	
Select Graphics Page On/Off	GPn,m	Turn graphics page n (1 to 8) on/off (m = 1 or 0). Pages 1 through 7 may use up to 500 16 bit words. Page 8 may contain up to 4000 words. GP without parameters selects and turns on page 1. Also resets point to start of page.	
Default Colors ¹	DEC	Pen Number	Color
		0	Black
		1	Bright White
		2	Half-bright White
		3	Dim White
		4	Red
		5	Half-bright White
		6	Dim White
		7	Bright White
		8	Gold
		9	Gold
		10	Blue
		11	Blue
		12	Salmon
		13	Salmon
		14	Green
		15	Green
Select HP BASIC Default Colors ¹	BC	0	Black
		1	White
		2	Red
		3	Yellow
		4	Green
		5	Cyan
		6	Blue
		7	Magenta
		8	Black
		9	Olive Green
		10	Aqua
		11	Royal Blue
		12	Maroon
		13	Brick Red
		14	Orange
		15	Brown
Default Monochrome ¹	DF	0	Black
		1	Bright Green
		2	Half-bright Green
		3	Dim Green

1. HP 8757D only.

Table 5. HP 8757D/E Modified ASCII Character Set

HP 8757D/E MODIFIED ASCII CODE CONVERSION TABLE								
Note: These characters are output only when the LB command is used directly.								
LEAST SIGNIFICANT CHARACTER	MOST SIGNIFICANT CHARACTER							
	0	1	2	3	4	5	6	7
0	null	centered*	space	0	@	P	'	p
1	HP logo	centered o	!	1	A	Q	a	q
2	β	↑	"	2	B	R	b	r
3	ETX	←	#	3	C	S	c	s
4	upper-half tic	↓	\$	4	D	T	d	t
5	lower-half tic	→	%	5	E	U	e	u
6	left-half tic	✓	&	6	F	V	f	v
7	right-half tic	π	'	7	G	W	g	w
8	back space	Δ	(8	H	X	h	x
9	1/2 shift down	μ)	9	I	Y	i	y
A	line feed	° (degree)	*	:	J	Z	j	z
B	inv. line feed	Ω	+	;	K	[k	{
C	1/2 shift up	ε	'	<	L	\	l	
D	carriage return	Γ	-	=	M]	m	}
E	horizontal tic	θ	.	>	N	^	n	□
F	vertical tic	λ	/	?	O	—	o	▶

<u>EXAMPLES:</u>		
HP logo	=	01
A	=	41
i	=	69
✓	=	16
▶	=	7F
line feed	=	0A
ETX	=	End of text; use to end labelling

Table 6. HP 8757D File Extensions

Disk files created by the HP 8757D can be read on any HP 9000 Series 200/300 computer. Each file has an extension appended which serves to identify the file type.		
File Type	Extension	
Instrument State	IS	
Measurement Data Channel q	Dq	
Memory Data Channel q	Mq	
CRT Graphics	CG	
Trace Display Data Channel q	Nq	
Where q represents a channel number 1 to 4.		File identities are determined by their extensions. For example, a normalized data file for channel 2 named "FILE1" would have "N2" appended resulting in "FILE1N2".

Table 7. HP 8757D/E Status Byte Descriptions

STATUS BYTE (#1)								
BIT #	7	6	5	4	3	2	1	0
Decimal Value	128	64	32	16	8	4	2	1
Function	N/A	Request Service (SRQ)	SRQ on HP-IB Syntax Error	SRQ on Operation Complete (Sweep, Plot or Print)	SRQ on Softkey Only Pressed	SRQ on Change in Extended Status Byte	SRQ on Numeric Entry Completed (HP-IB or Front Panel)	SRQ on Any Front Panel Key Pressed
EXTENDED STATUS BYTE (#2)								
BIT #	7	6	5	4	3	2	1	0
Decimal Value	128	64	32	16	8	4	2	1
Function	N/A	SRQ on Detector Uncal	SRQ on Front Panel Preset or Power-on	SRQ on Limit Test Failed ¹	SRQ on Action Requested not possible	SRQ on Knob Activity	SRQ on Operation Failure ¹	SRQ on Self Test Failure

1. HP 8757D only

Table 8. Front Panel Keycodes (values are in decimal)

SOFTKEYS Softkey 1 (top) = 32 Softkey 2 = 8 Softkey 3 = 0 Softkey 4 = 16 Softkey 5 = 14 Softkey 6 = 38 Softkey 7 = 40 Softkey 8 (bottom) = 41	ENTRY Step down = 22 Step up = 6 0 Key = 20 1 Key = 4 2 Key = 3 3 Key = 7 4 Key = 12 5 Key = 11 6 Key = 15 7 Key = 36 8 Key = 35 9 Key = 39 . Key = 19 - Key = 23 Entry off = 9 Enter = 1 dBm/dB = 33 Backspace = 17
CHANNEL Channel 1 = 42 Channel 2 = 43 Channel 3 = 24 Channel 4 = 25	INSTRUMENT STATE System = 51 Save = 28 Recall = 26 Local = 29
FUNCTION Measurement = 44 Display = 45 Scale = 52 Reference = 46 Cursor = 47 Averaging = 48 Calibration = 49 Special = 50	

Table 9. Alphabetical Listing of HP 8757D/E Programming Codes (1 of 3)

Code	Action	Page	Code	Action	Page
A0	Averaging off	9	CLW	Color list, white ¹	13
AB	A/B ratio measurement	8	CLY	Color list, yellow ¹	13
AC	A/C ratio measurement ²	8	CN	Cursor to minimum	9
AFd	Averaging on and factor d	9	COBd	Brightness adjust, one color ¹	13
ANm	Adaptive Normalization on/off ¹	12	COCd	Color adjust, one color ₁	13
AR	A/R ratio measurement	8	COTd	Tint adjust, one color ¹	13
AS	Autoscale	8	CR	C/R ratio measurement ²	8
AZ2	Autozero the DC detectors once	9	CS	Clear status bytes	15
AZm	Autozero repeat on/off of the DC detectors	9	CTm	Auto system calibration on/off	12
BA	B/A ratio measurement	8	CUm	Cursor on/off	9
BC	B/C ratio measurement ²	8	CWm	CW mode on/off	12
BFm	Plotter buffer on/off ¹	10	CX	Cursor to maximum	9
BL0	Restore CRT to normal mode	15	DAd	Detector A amplitude offset set to d	11
BL1	Blank frequency labels (secure frequency mode, frequency labels cannot be restored)	15	DBd	Detector B amplitude offset set to d	11
BL2	Blank all labels	15	DCd	Detector C amplitude offset set to d ²	11
BL3	Blank active channel trace	15	DEC	Set default colors ¹	13
BL4	Blank softkey labels	15	DFA	Set disk format to ASCII ¹	14
BL5	Blank all (except user CRT graphics)	15	DFB	Set disk format to binary ¹	14
BL6	Blank title	15	DFE	Set Disk format to extended binary ¹	14
BL7	Blank mode labels	15	DHm	Display Hold on/off of the active channel trace	8
BL8	Blank the active entry area	15	DIAd	Set disk HP-IB address ¹	14
BL9	Blank the limit lines ¹	15	DIUd	Set disk unit number ¹	14
BLA	Blank all (except user CRT graphics and softkeys)	15	DIVd	Set disk volume number ¹	14
BLB	Blank the user CRT graphics	15	DLF	Delete file from disk ¹	14
BR	B/R ratio measurement	8	DM0	All inputs set to DC detection	11
BTNd	Overall display brightness	13	DM1	All inputs set to AC detection	11
BW	Display the search bandwidth on the CRT ¹	9	DN	Step down (decrement)	9
C0	Channel off	8	DOAd	Measure Detector A amplitude offset ¹	11
C1	Channel 1 on/active	8	DOBd	Measure Detector B amplitude offset ¹	11
C2	Channel 2 on/active	8	DOCd	Measure Detector C amplitude offset ²	11
C3	Channel 3 on/active ¹	8	DORd	Measure Detector R amplitude offset ¹	11
C4	Channel 4 on/active ¹	8	DRd	Detector R amplitude offset set to d	11
CA	C/A ratio measurement ²	8	DS0	Display trace data in log magnitude	8
CB	C/B ratio measurement ²	8	DS1	Display trace data in standing wave ratio (SWR) format	8
CC1	Set channel 1 color ¹	13	DTSTPAs	Enter stop frequency for detector A ³	12
CC2	Set channel 2 color ¹	13	DTSTPBs	Enter stop frequency for detector B ³	12
CC3	Set channel 3 color ¹	13	DTSTPCs	Enter stop frequency for detector C ^{2,3}	12
CC4	Set channel 4 color ¹	13	DTSTPRs	Enter stop frequency for detector R ³	12
CDm	Cursor delta on/off	9	DTSTRAs	Enter start frequency for detector A ³	12
CGL	Set labels color ¹	13	DTSTRBs	Enter start frequency for detector B ³	12
CGN	Set background color ¹	13	DTSTRCs	Enter start frequency for detector C ^{2,3}	12
CGR	Set grid color ¹	13	DTSTRRs	Enter start frequency for detector R ³	12
CGW	Set warning label color ¹	13	EO	Enter measured detector amplitude offset	11
CL	Perform system configuration of detectors and channels	12	ER0	Erase all save/recall registers	13
CLB	Color list, black ¹	13	FAs	Start frequency label	11
CLG	Color list, green ¹	13	FBs	Stop frequency label	11
CLR	Color list, red ¹	13	FD0	Format data ASCII	15
CLS	Color list, salmon ¹	13			

1. HP 8757D only.

2. HP 8757D Option 001 only.

3. HP 8757D with HP 85037 series precision detectors only.

Table 9. Alphabetical Listing of HP 8757D/E Programming Codes (2 of 3)

Code	Action	Page	Code	Action	Page
FD1	Format data binary (HP BASIC compatible)	15	MU4	Display the cursor menu	13
FD2	Format data extended ASCII	15	MU5	Display the average menu	13
FD3	Format data binary (PC compatible)	15	MU6	Display the calibration menu	13
FD4	Format data extended binary (HP BASIC compatible)	15	MU7	Display the special menu	13
FD5	Format data extended binary (PC compatible)	15	MU8	Display the system menu	13
FR0	Logarithmic (dB) cursor format	9	MY	Display memory data	8
FR1	SWR cursor format	9	MZ	Manual calibration of DC detectors	9
FSm	Step sweep on/off ³	12	NSm	Non-standard sweep mode on/off	12
FTAm	Detector A frequency on/off ⁵	12	OC	Output cursor value	17
FTBm	Detector B frequency on/off ⁵	12	OD	Output trace data	17
FTCm	Detector C frequency on/off ^{2,5}	12	OE1	Output error status of display channel 1	18
FTRm	Detector R frequency on/off ⁵	12	OE2	Output error status of display channel 2	18
IA	Input A absolute power measurement	8	OI	Output identity	18
IB	Input B absolute power measurement	8	OK	Output keycode of last key pressed	18
IC	Input C absolute power measurement ²	8	OL	Output learn string	17
ILs	Input Learn string	16	OM	Output memory data	17
IND	Initialize disk format ¹	14	ON	Output normalized (measurement —memory) data	17
IP	Instrument preset	13	OPDO	Output measured detector amplitude offset	11
IR	Input R absolute power measurement	8	OPx	Output interrogated parameter value x = AF, BW, DA, DB, DC, DS, NS, OD, OM, ON, DR, DTSTP, DTSTR, RL, RE, SD, SL, SO, SP, SR, SS, ST	12,17
IX	External ADC input (AUX) voltage measurement ³	8	OR	Output rotary knob value (—32768 ≤ value ≤ +32767)	18
LE	Erase limit lines for active channel ⁴	10	OS	Output status bytes	18
LFA	Load instrument information file from disk ¹	14	OT1m	Control output #1 on/off	16
LFC	Load CRT graphics file from disk ¹	14	OT2m	Control output #2 on/off	16
LFD	Load data trace file from disk ¹	14	OV	Output CW value	17
LFF	Load measurement file from disk. ¹	14	P1	Plot channel 1 trace on external plotter	10
LFH	Load instrument information file from disk and place instrument in hold mode. ¹	14	P2	Plot channel 2 trace on external plotter	10
LFI	Load instrument state file from disk ¹	14	P3	Plot channel 3 trace on external plotter ¹	10
LFM	Load memory trace file from disk ¹	14	P4	Plot channel 4 trace on external plotter ¹	10
LFN	Load display trace file from disk. ¹	14	PA	Plot all on external plotter	10
LFs	Enter limit test flat line data ⁴	10	PBm	System interface control on/off	12
LL	Store lower limit line into memory ⁴	10	PC	Plot labels on external plotter	10
LPs	Enter limit test point data ⁴	10	PD	Plot custom plot	10
LSs	Enter limit test sloped line data ⁴	10	PG	Plot grid on external plotter	10
LTm	Limit line test on/off ⁴	10	PR1	Print all to monochrome printer, except softkeys and CRT graphics	10
LU	Store upper limit line into memory ⁴	10	PR2	Print tabular display data in monochrome	10
M-	Display normalized data (measurement — memory)	8	PR3	Print tabular marker/cursor data to external printer	10
MDm	Modulation on/off	12	PR4	Print all to color printer, except softkeys and CRT graphics ¹	10
ME	Display measurement data	8	PTd	Passthrough address set to d	16
MN	Display normalized data (same as M-)	8	PWRA	Execute a detector A power calibration ¹	11
MOC	Monochrome display ¹	13	PWRB	Execute a detector B power calibration ¹	11
MR	Marker (or cursor) to reference line	8	PWRC	Execute a detector C power calibration ²	11
MSm	Manual sweep mode on/off	12	PWRR	Execute a detector R power calibration ¹	11
MU0	Display the measurement menu	13	R1	R/A ratio measurement	8
MU1	Display the display menu	13			
MU2	Display the scale menu	13			
MU3	Display the reference menu	13			

1. HP 8757D only.

2. HP 8757D Option 001 only.

3. HP 8340, HP 8341, or HP 8360 series synthesized sweeper only with 8757 SYSTEM INTERFACE connected and active.

4. Limit line functions valid only for channels 1 or 2. HP 8757D only.

5. HP 8757D with HP 85037 series precision detectors only.

Table 9. Alphabetical Listing of HP 8757D/E Programming Codes (3 of 3)

Code	Action	Page	Code	Action	Page
R2	R/B ratio measurement	8	SPd	Number of points set to d: d=101, 201, 401, 801 ¹ , 1601 ¹	11
R3	R/C ratio measurement ²	8			11
RCn	Recall register n	13	SR	Cursor search right ¹	9
RLd	Reference level set to d	8	SSd	Cursor search value set to d ¹	9
RMd	Service request mask set to d	15	STd	Reference level step size set to d	8
RPq	Reference position set to vertical division q	8	SUd	Specify custom plot according to d	10
RS	Restart averaging	9	SVn	Save register n	13
SCd	Set cursor to horizontal position d	16	SW0	Non-swept mode; non-swept operation	16
SDd	Scale per division set to d	8	SW1	Swept mode; normal swept operation	16
SFA	Store all instrument information to disk in file ¹	14	SW2	Sweep hold mode; non-swept mode with HP-IB bus hold off until completion of TSd	16
SFC	Store CRT graphics to disk in file ¹	14	TCm	Continuous Temperature Compensation on/off	12
SFD	Store data trace to disk in file ¹	14	TIFs	Title for file ¹	14
SFF	Store measurement trace to disk file ¹	14	TSd	Take d sweeps, then hold display	16
SFI	Store instrument state to disk in file ¹	14	UP	Step up (increment)	9
SFM	Store memory trace to disk in file ¹	14	WKs	Write softkey label	16
SFN	Store normalized trace to disk in file ¹	14	WMs	Write to channel memory.	16
SKq	Select softkey q; q =1 to 8	13	WTs	Write title, s is an ASCII string of up to 50 characters	16
SL	Cursor search left ¹	9	XAd	External detector cal value for detector A	11
SM	Store measurement into memory	8	XBd	External detector cal value for detector B	11
SN	Store normalized data (measurement - memory) into memory	8	XCd	External detector cal value for detector C ²	11
SOd	Smoothing set to d % of frequency span	9	XRd	External detector cal value for detector R	11
			ZTd	Repeat auto zero timer set to d	9

1. HP 8757D only.
2. HP 8757D Option 001 only (detector C).

NOTES: n = decimal integer 1 to 9
d = variable length numeric
m = 0 for off/1 for on
q = unique value
s = ASCII or binary string

For more information, call your local HP sales office listed in your telephone directory or an HP regional office listed below for the location of your nearest sales office.

United States:

Hewlett-Packard Company
4 Choke Cherry Road
Rockville, MD 20850
(301) 670-4300

Hewlett-Packard Company
5201 Tollview Drive
Rolling Meadows, IL 60008
(312) 255-9800

Hewlett-Packard Company
5161 Lankershim Blvd.
No. Hollywood, CA 91601
(818) 505-5600

Hewlett-Packard Company
2015 South Park Place
Atlanta, GA 30339
(404) 955-1500

Canada:

Hewlett-Packard Ltd.
6877 Goreway Drive
Mississauga, Ontario L4V1M8
(416) 678-9430

Australia/New Zealand:

Hewlett-Packard Australia Ltd.
31-41 Joseph Street,
Blackburn, Victoria 3130
Melbourne, Australia
(03) 895-2895

Europe/Africa/Middle East:

Hewlett-Packard S.A.
Central Mailing Department,
P.O. Box 529
1180 AM Amstelveen,
The Netherlands
(31) 20/547 9999

Far East:

Hewlett-Packard Asia Ltd.
22/F Bond Centre
West Tower
89 Queensway
Central, Hong Kong
(5) 8487777

Japan:

Yokogawa-Hewlett-Packard Ltd.
29-21, Takaido-Higashi 3-chome
Suginami-ku, Tokyo 168
(03) 331-6111

Latin America:

Latin American Region Headquarters
Monte Pelvoux Nbr. 111
Lomas de Chapultepec
11000 Mexico, D.F. Mexico
(905) 596-79-33

July 15, 1992

HP Part Number 08757-90130
Printed in U.S.A.



Addendum to HP-IB Programming Note Quick Reference Guide for the HP 8757D/E Scalar Network Analyzer

The following table provides additional codes for Tables 1 and 3 of the HP-IB Programming Note, Quick Reference Guide for the HP 8757D/E Scalar Network Analyzer.

Table 6-1. Function Select Commands

Action	HP-IB Command	Syntax	Description
Time/Date Stamp	TDm	2	Time/Date Stamp on/off m = 0 function off m = 1 function on
	TM	4	Set Time Format: HH:MM:SS Where: H = hour, M = minute, S = second format is 24 hours Example: 14:05:02 Example: "TM" & TIME\$ (TIMEDATE)
	DT	4	Set Date Format: "DD Mmm YYYY" Where: DD=day, Mmm=month, YYYY=year Example: 02 Mar 1993 Example: "DT" && DATE\$ (TIMEDATE) Note: Mmm is not case sensitive. Allowed values are Jan, Feb, Mar, and so on.

Table 6-3. Output Modes

Action	HP-IB Command	Description	Format
Output Time/Date	OPTM	Output Current Time	ASCII String: "HH:MM:SS" H=hour, M=minute, S=second Example: 14:05:02
	OPDT	Output Current Date	ASCII String: "DD Mmm YYYY" Note: Mmm is not case sensitive. Allowed values are Jan, Feb, Mar, and so on.

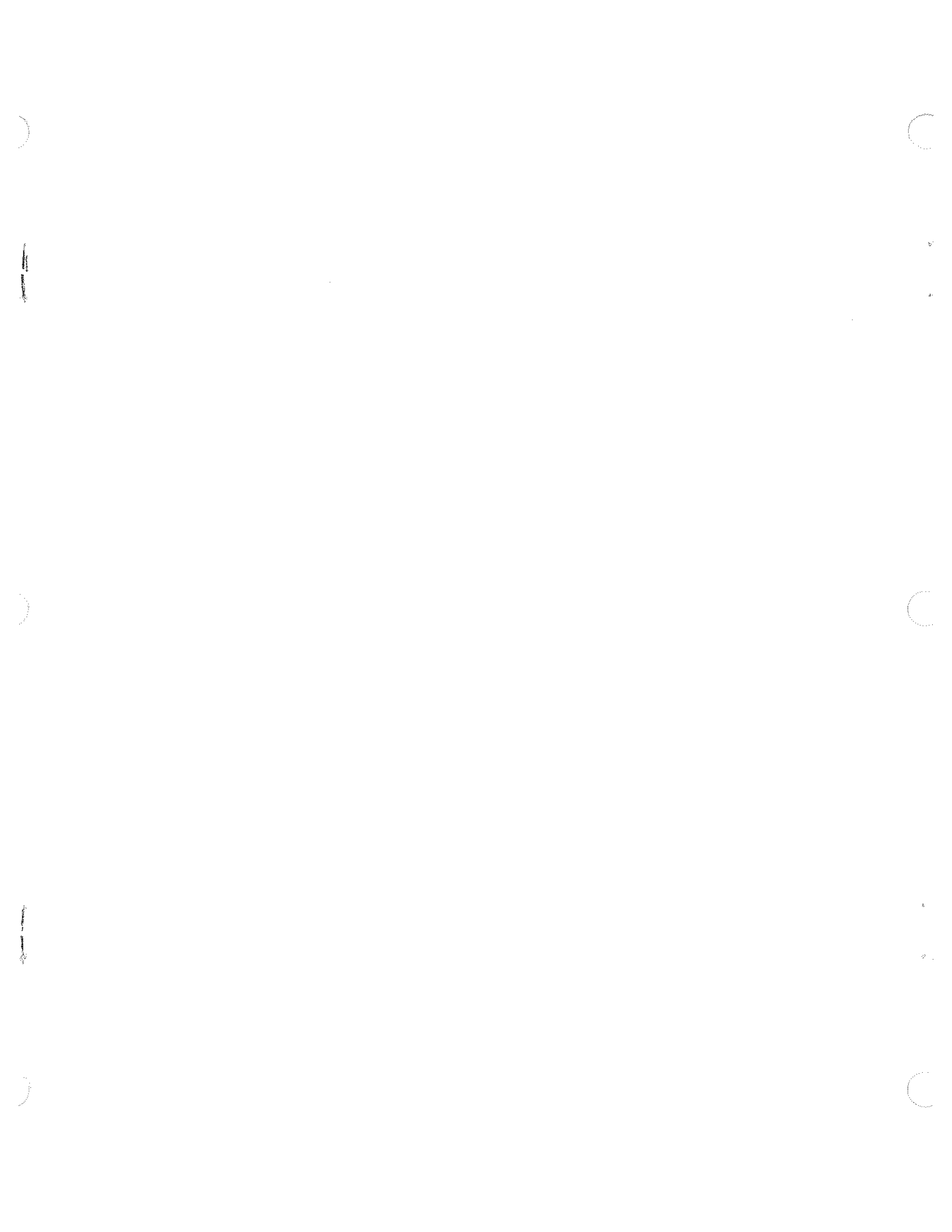

Introductory Programming Guide

For the HP 8757D/E scalar network analyzer with the HP 9000 series 200/300 desktop computer (BASIC)

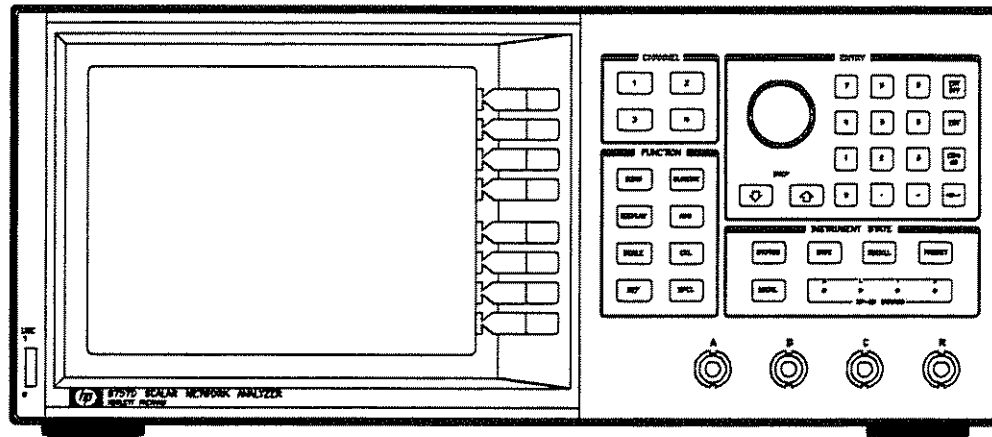

Introduction

This programming note describes the remote operation of the HP 8757D/E Scalar Network Analyzer with the HP 9000 Series 200/300 desktop computer used as a controller. This includes the HP Vectra PC configured with the HP 82300D measurement coprocessor or HP 832324B high performance measurement coprocessor. Included in this guide are several short programs that demonstrate the use of the analyzer with HP-IB commands, and a diagram of system connections for remote control.

The HP 8757D/E is a fully programmable analyzer capable of making magnitude-only transmission and reflection measurements over an RF and microwave frequency range of 10 MHz to 110 GHz. When used with an HP-IB computer, the analyzer's front panel may be remotely controlled, along with most softkey functions and some functions accessible only via HP-IB. The analyzer exerts control over a source (HP 8350B, HP 8340B/41B or HP 8360 series), digital plotter (HP 7440A or HP 7550A), and printer (HP 2225A ThinkJet, HP 3630A PaintJet, or HP 2227B QuietJet Plus) connected to the 8757 SYSTEM INTERFACE.

This note assumes you are familiar with front panel (local) operation of the HP 8757D/E. If not, refer to the operating manual. You should also be familiar with the HP 9000 Series 200/300 computer, particularly HP-IB operation. Throughout the rest of this document, the term *computer* refers to any of these computers.

Reference information

The following texts provide additional information on the HP Interface Bus, the analyzer, the source, or the computer. See "Replaceable Parts" for ordering information.

HP 8757 literature

- HP 8757D Operating Manual.
- HP 8757C/E Operating Manual.
- Programming Note: *Quick Reference Guide for the HP 8757C/E Scalar Network Analyzer.*

Source literature

- Programming Note: *Introductory Operating Guide for the HP 8350B Sweep Oscillator with the HP 9000 Series 200 Computers (BASIC).*
- Programming Note: *Quick Reference Guide for the HP 8350B Sweep Oscillator.*
- Programming Note: *Introductory Operating Guide for the HP 8340A Synthesized Sweeper with the HP 9000 Series 200 Computers (BASIC).*
- Programming Note: *Quick Reference Guide for the HP 8340B Synthesized Sweeper.*
- Product Note: *HP 8340/41 to HP 8360 System Conversion Guide.*
- *HP 8360 Series Synthesized Sweepers Quick Reference Guide.*
- *HP 8360 Operating and Programming Reference Manual.*

HP 9000 series 200/300 computer literature

- BASIC Operating Manual.
- BASIC Programming Techniques.
- BASIC Language Reference.
- BASIC Interfacing Techniques.
- BASIC Graphics Techniques.

General HP-IB literature

- Condensed Description of the Hewlett-Packard Interface Bus.
- Tutorial Description of the Hewlett-Packard Interface Bus.

Equipment required

- 1 HP 8757D/E Scalar Network Analyzer.
- 1 HP 8350B Sweep Oscillator with plug-in or HP 8340B/41B Synthesized Sweeper or HP 8360 Series Synthesized Sweeper.
- 1 HP 9000 Series 200/300 Computer with BASIC 5.0 or higher, and at least 64K bytes of free user memory.
- 1 HP 85027A/B/C/D/E Directional Bridge.
- 1 HP 11664A/E Detector or HP 85025A/B/D/E Detector with connector type to match bridge and test device.
- 1 Shielded open circuit with connector to mate with bridge.
- 1 Short circuit with connector to mate with bridge.
- 3 HP 11170C BNC cables, 122 cm (48 in.). (4 are needed with HP 8340B/41B).
- 2 HP 10833A/B/C/D HP-IB cables.
- 1 Test device.

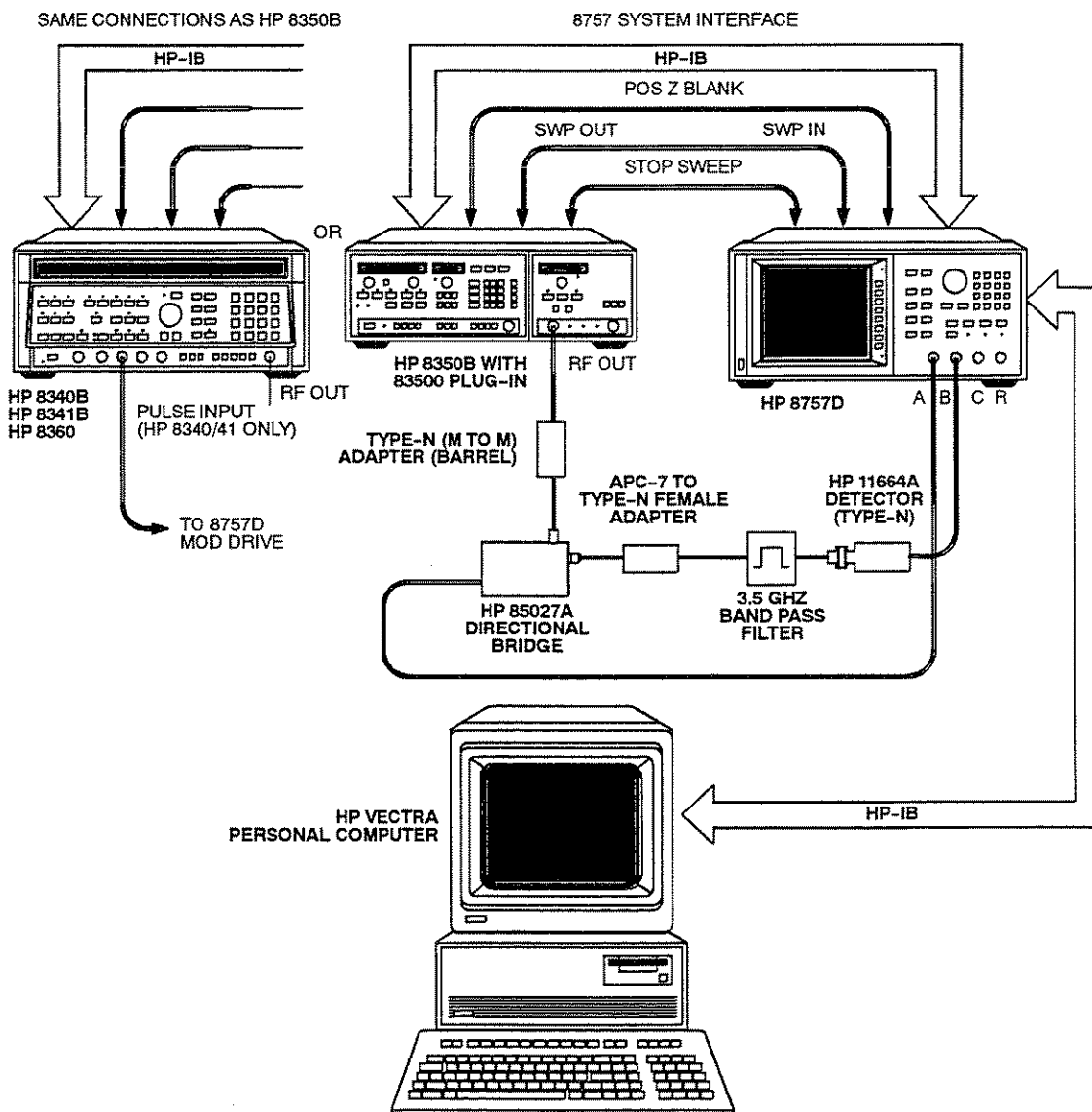

Figure 1. System Connections

Set-up

Connect the instruments as shown in figure 1. The following procedure sets the HP-IB addresses of the instruments to operate properly with the programs contained in this guide.

1. Turn on the HP 8350B Sweep Oscillator. Press **[SHIFT] [LCL]**. The FREQUENCY/TIME display shows the current HP-IB address of the source. If it is not 19, press **[1] [9]** to set the address to 19. The HP 8340B or 8341B Synthesized Sweeper operates the same, although the address is displayed in the right-hand display area.
2. Power on the HP 8757D/E Scalar Network Analyzer. The current HP-IB address is shown in the active entry area of the CRT. If it is not 16, press **[LOCAL] [8757] [1] [6] [ENT]** to set the address to 16.
3. Turn on your computer and your load BASIC operating system. Ensure that the following binary (BIN) programs are loaded: DISC, CS80, HPIB, GRAPH, ERR, and IO. LIST BIN lets you view the currently loaded binaries.

Check out procedure

1. Press **[PRESET]** on the analyzer. If the 8757 SYSTEM INTERFACE is properly connected, and the address of the source correctly set, both the analyzer and the source will perform an instrument preset. If either instrument detects a failure during instrument preset, that instrument displays the error encountered. The operating manual of the source gives instructions to help you interpret the error message. If the analyzer displays an error message, see "In Case of Difficulty."
2. To verify the HP-IB connections made between the analyzer and the computer, perform the following:
Type "REMOTE 716" and press **[EXECUTE]**.

The R (remote) and L (listen) lights in the analyzer INSTRUMENT STATE area will light. The analyzer has received its HP-IB listen address.

Programming examples

In the following sections, example programs introduce the HP-IB capabilities of the analyzer. Each example program consists of these sections:

1. A description of the functions exercised.
2. The program listing.
3. An explanation of each program line.
4. Detailed instructions for operating the program.

1. HP 8757D only.
2. HP 8757D Option 001 only.

When you finish all of the example programs, you will have a good idea of the power of the HP 8757D/E when used in an automatic system.

Program 1: remote, local, and local lockout

The analyzer may be used with the front panel (local operation) or programmed via HP-IB (remote operation). The programmer of the instrument system has control over the operation of all instruments in the system.

When the computer first addresses an instrument, the instrument is placed in a special remote operating mode, called remote mode. When in remote, the instrument does not respond to its front panel, except for the **[LOCAL]** key. **[LOCAL]**, when pressed, cancels the remote mode and allows the instrument to be used with its front panel.

The computer can also return the instrument to local operation. To do so, the computer sends a special command that forces the instrument to go to local mode.

Occasionally, the programmer of an automatic system needs to prevent the instrument operator from returning the instrument to local operation (via **[LOCAL]**). When the local lockout function of the computer is used, the instruments are prevented from exiting remote mode, even when **[LOCAL]** is pressed.

Frequently, the programmer needs to place the instruments connected to the computer into a known state. When preset, the analyzer defaults to the conditions shown below. The instrument preset function operates the same as the front panel **[PRESET]** key on the analyzer and the source. When presetting the analyzer and source, send the PRESET command only to the analyzer. The analyzer will preset the source attached to the 8757 SYSTEM INTERFACE.

HP 8757C/E instrument preset conditions

Channels 1 and 2 on. The channel menu appears in the softkey label area of the CRT.

- Measure power A on channel 1.
- Measure power B on channel 2.
- Measure power C² (or B) on channel 3¹.
- Measure power R on channel 4¹.
- Display measurement data in log magnitude format.
- Scale = 20 dB/div.
- Reference level 0 dB for all channels.
- Reference level step size = 20 dB.
- Averaging off.
- Averaging factor = 8.
- Cursor off.
- All labels on.

- Channel 1 as the active channel.
- Modulation drive on.
- Number of points =401.
- Detector mode set for AC detection.
- Smoothing set for 5.0% of span (off).
- Cursor format = log magnitude.
- Search value = -3 dB¹.
- Adaptive normalization off¹.
- Temperature compensation on.
- Repeat autozero off.
- Detector offset reset to zero.²
- Detector frequency off, start and stop set to 50 MHz.¹

Source

- Instrument preset.
- Sweep time set to 200 ms.
- HP 8350B square wave modulation on.
- HP 8340/41 SHIFT PULSE on; RF Output on.
- HP 8360 scalar modulation on; RF output on; ramp sweep mode; analyzer mode.

Plotter

- Abort plot if in progress.
- P1 and P2 scaling points unchanged.
- Selection of plotter pens unchanged.

Printer

- Abort plot if in progress.

Disk drive¹

- Aborts any data transfers in progress.
- Unit number unchanged.
- Volume number unchanged.
- ASCII or binary mode unchanged.

The following analyzer conditions are not changed during a PRESET (IP) command execution:

- Reference position.
- Trace memory.
- Save/Recall registers.
- HP-IB addresses.
- Request mask.
- Limit lines¹.
- Title.
- User-defined plot.
- 8757 System Interface control on/off.
- Repeat autozero timer.
- Display intensity.
- Display colors¹.

1. HP 8757D only.

2. Detector offset remains unchanged for HP 8757E.

Program 1 listing

```

10  ASSIGN @Sna TO 716
20  ABORT 7
30  CLEAR @Sna
40  REMOTE @Sna
50  PAUSE
60  REMOTE @Sna
70  LOCAL LOCKOUT 7
80  PAUSE
90  LOCAL 7
100 PAUSE
110 OUTPUT @Sna;"IP"
120 END

```

Program 1 explanation

- Line 10 Assign the address of the HP 8757D/E to an I/O path. This is not required, but it is good programming practice. If you change the address of the instrument later, you only change the address in one place in your program.
- Line 20 Abort any HP-IB transfers and reset the computer's HP-IB interface.
- Line 30 Clear the analyzer's HP-IB interface.
- Line 40 Set the analyzer and source to remote mode.
- Line 50 Temporarily stop execution.
- Line 60 Set the analyzer and source to remote mode.
- Line 70 Lock out the [LOCAL] key of the analyzer and source.
- Line 80 Temporarily stop execution.
- Line 90 Set the analyzer and source to local mode.
- Line 100 Temporarily stop execution.
- Line 110 Preset the analyzer and source.
- Line 120 End program execution.

Running program 1

1. Press [SHIFT] [RESET] on the computer. Type "SCRATCH" and press [EXECUTE]. This clears the program memory of the computer.
2. Type in the program.
3. Press [RUN] on the computer.
4. When the program stops, the analyzer is in remote mode. You can verify this by observing the lights in the INSTRUMENT STATE area of the analyzer. The R (remote) and L (listen) lights should be on. Try pressing any key on the analyzer (except [LOCAL]). Nothing happens. The source is also in remote mode. Now press [LOCAL] and verify that the keys on the analyzer are active. Also, notice the R light went out when you pressed [LOCAL]. The source went into local mode along with the analyzer.

5. Press [Continue] on the computer. The analyzer is again in remote mode. This time, however, the [LOCAL] key is locked out. Try pressing [LOCAL] and the other keys. None of the keys on the analyzer or the source cause any action.
6. Press [Continue] on the computer. All instruments on the HP-IB interface are returned to local mode, including the analyzer and source. To set only the analyzer into local mode, the LOCAL 716 command can be given from the computer. Verify that the R light on the analyzer is off and the REM light on the source is off.
7. Press [Continue] on the computer. The analyzer and source are both preset. Note that the computer sent the instrument PRESET command only to the analyzer. The analyzer, in turn, preset the source.

Remember, to preset both the analyzer and the source, you only need to send the instrument PRESET command to the analyzer. Do not send instrument PRESET to the source by way of passthru mode (discussed in program 3).

Program 2: controlling the front panel

All front panel keys and most of the softkeys of the analyzer may be programmed remotely via HP-IB. For example, you can program the scale per division, reference level, and reference position for each channel.

Program 2 listing

```

10  ASSIGN @Sna TO 716
20  ABORT 7
30  CLEAR @Sna
40  OUTPUT @Sna;"IP"
50  PAUSE
60  OUTPUT @Sna;"C1C0C2"
70  PAUSE
80  OUTPUT @Sna;"SD10"
90  PAUSE
100 OUTPUT @Sna;"RL-10"
110 PAUSE
120 OUTPUT @Sna;"RP4"
130 PAUSE
140 OUTPUT @Sna;"IA"
150 PAUSE
160 OUTPUT @Sna;"C0C1 SD5; RP4; RL-5"
170 END

```

Program 2 explanation

- Line 10 Assign an I/O path to the HP-IB address of the HP 8757D/E.
- Line 20 Abort any transfers and clear the HP-IB interface of the computer.
- Line 30 Clear the HP-IB interface of the analyzer.
- Line 40 Preset the analyzer and the source.

- Line 50 Temporarily stop execution.
- Line 60 Select channel 1 and turn it off. Turn channel 2 on.
- Line 70 Temporarily stop execution.
- Line 80 Set the scale per division to 10 dB. No terminator (;) is needed because this is the last command in the statement.
- Line 90 Temporarily stop execution.
- Line 100 Set the reference level to -10 dBm. Again, note the absence of a terminator (;).
- Line 110 Temporarily stop execution.
- Line 120 Set the reference position line to the center of the CRT (4th graticule). No terminator is needed because this is the last command on the line.
- Line 130 Temporarily stop execution.
- Line 140 Program channel 2 to measure reflection (input A) instead of transmission (input B).
- Line 150 Temporarily stop execution.
- Line 160 Many commands on one line, with terminators. Turn channel 2 off (C2C0) and channel 1 on (C1). Set the scale per division (SD) to 5 dB, the reference position line (RP) to the center of the CRT, and the reference level (RL) to -5 dBm.
- Line 170 End execution.

Running program 2

1. Type "SCRATCH" and press [EXECUTE] on the computer. This erases the previous program.
2. Type in this program and press [RUN] on the computer.
3. The computer presets the analyzer and source and pauses. Note the settings of channel 1 and 2, then press [Continue].
4. Channel 1 is turned off. Channel 2 is now the active channel, as you can see from the highlighted box around the channel 2 mode labels on the analyzer CRT. Press [Continue].
5. Channel 2 scale per division is now set to 10 dB. It defaulted to 20 dB/div at preset. Press [Continue].
6. The reference level is set to -10 dBm (it was 0.0 dBm). Press [Continue].
7. The reference position line is set to the center of the CRT (graticule 4). The top of the CRT is graticule 8 and the bottom is graticule 0. Press [Continue].
8. Change the measurement to reflection (input A), instead of transmission (input B). At preset, channel 2 defaults to input B. Press [Continue].
9. In one statement: turn off channel 2, turn on channel 1, set the scale per division to 5 dB, set the reference position line to the center of the CRT, and set the reference level to -5 dBm.

NOTE: The semicolon (;) terminators are needed after any analyzer command that can have a variable length. Extra terminators never hurt, so use them liberally.

Program 3: passthru mode

In normal operation, the system source, digital plotter, printer, and disk drive (HP 8757D only) are connected to the 8757 SYSTEM INTERFACE. This connection allows the analyzer to control and extract information from the other parts of the measurement system. To allow you to control the source and plotter with the computer, the analyzer has a built-in PASSTHRU command that takes a command from the computer and passes it on to one of the instruments connected to the 8757 SYSTEM INTERFACE.

To initiate passthru mode, first tell the analyzer which instrument you wish to command by setting the passthru address. Then, to talk (or listen) to that device, address the analyzer's special passthru HP-IB address (which is different from the analyzer's HP-IB address). While in the passthru mode, the analyzer stops updating its CRT and does not respond to its front panel (because it's in remote mode). To remove the analyzer from passthru mode, simply address it via HP-IB. While in passthru mode, do not press [LOCAL] on the analyzer.

The analyzer's passthru address is calculated from its HP-IB address. If the address of the analyzer is even (such as 16 decimal) then the passthru address is the next larger number (17 decimal). If the address of the analyzer is odd (such as 15 decimal), then the passthru address is the next smaller number (14 decimal). Never set the address of the analyzer such that its address conflicts with one of the instruments connected to the 8757 SYSTEM INTERFACE. For instance, if the source is set to 19 decimal, do not set the address of the analyzer to 19.

Data can be sent to or received from any instrument on the 8757 SYSTEM INTERFACE via passthru mode. LOCAL, REMOTE, and TRIGGER HP-IB messages do not pass through the analyzer.

Program 3 listing

```

10  PRINTER IS 1
20  ASSIGN @Sna TO 716
30  ASSIGN @Passthru TO 717
40  ABORT 7
50  CLEAR @Sna
60  OUTPUT @Sna;"IP"
70  OUTPUT @Sna;"PT19"
80  OUTPUT @Passthru;"OPFA"
90  ENTER @Passthru;Min_freq
100 Min_freq=Min_freq/1.E+9
110 OUTPUT @Passthru;"OPFB"
120 ENTER @Passthru;Max_freq
130 Max_freq=Max_freq/1.E+9
140 OUTPUT @Sna

```

```

150 PRINT "Frequency limits:";Min_freq;"to";Max_freq;"GHz"
160 INPUT "Start_frequency (GHz)?",Start_freq
170 INPUT "Stop_frequency (GHz)?",Stop_freq
180 OUTPUT @Passthru;"FA";Start_freq;"GZ
    FB";Stop_freq;"GZ"
190 OUTPUT @Sna
200 END

```

Program 3 explanation

- Line 10 Direct the printed output to the computer CRT.
- Line 20 Assign an I/O path to the address of the analyzer. (This is the analyzer's control address).
- Line 30 Assign an I/O path to the analyzer's passthru address. By communicating to this HP-IB address, the computer will control a device connected to the 8757 SYSTEM INTERFACE.
- Line 40 Abort any transfers and clear the HP-IB interface of the computer.
- Line 50 Clear the HP-IB interface of the analyzer.
- Line 60 Preset the analyzer and source.
- Line 70 Tell the analyzer which device is controlled through the analyzer's passthru address. In this case, the source (device 19).
- Line 80 Send a command to the source. Command it to output its current start frequency.
- Line 90 Read the start frequency from the source.
- Line 100 Scale the start frequency to display it in GHz.
- Line 110 Command the source to output its current stop frequency.
- Line 120 Read the stop frequency from the source.
- Line 130 Scale the stop frequency to display it in GHz.
- Line 140 Exit passthru mode by addressing the analyzer.
- Line 150 Print the start and stop frequency.
- Line 160 Get the start frequency from the user.
- Line 170 Get the stop frequency from the user.
- Line 180 Set the start and stop frequency of the source to those given by the user.
- Line 190 Exit passthru mode by addressing the analyzer.
- Line 200 End program execution.

Running program 3

1. Clear the program memory of the computer and type in the program.
2. Press [RUN] on the computer.

- The computer presets the analyzer and the source, reads the start and stop frequency of the source, and displays it on the CRT of the computer. At preset, the source defaults to the full frequency range of the plug-in. The values read, then, represent the frequency limits of this plug-in. When the computer stops, it displays the prompt:

Start frequency (GHz)?

Enter a start frequency in the frequency range of the plug-in and press [Continue].

- The computer displays the prompt:

Stop frequency (GHz)?

Enter a stop frequency in the frequency range of the plug-in (but higher than the start frequency) and press [Continue].

- The computer sets the start and stop frequency of the source to those you entered. The analyzer immediately begins sweeping the frequency range you defined.
- Try deleting or "commenting out" line 190 in the program. Now, when the program ends, the analyzer shows the message **DATA PASSTHROUGH EXECUTING** and the display is frozen (not sweeping). To exit passthru mode, type "OUTPUT 716" and press [EXECUTE] on the computer. The analyzer displays **DATA PASSTHROUGH COMPLETE** and begins sweeping.

Points to remember: You must address the analyzer after using passthru mode to return it to normal swept operation. Any command can be sent via passthru mode to any instrument on the 8757 SYSTEM INTERFACE, and any data can be read. Service requests and parallel polls do not pass through the analyzer.

Program 4: cursor operations

To enhance the speed and accuracy of measurements, the analyzer contains a built-in cursor that displays the frequency and magnitude of a trace at any given point. To make measurements even more efficient, the cursor may be set to the maximum or minimum point on the trace simply by pressing a softkey. These cursor functions are available via HP-IB commands.

With a computer, the cursor may be turned on and off, its position (0 to n-1, where n is the number of points per trace) set, its value and position read, and set to the maximum or minimum point on the trace. The cursor functions all apply to the active channel. You have complete control over cursor operations via HP-IB.

Cursor programming is especially useful for measuring parameters like flatness and maximum power, where you are interested in the highest and lowest point on the trace. For measuring parameters such as 3 dB points and other specific points (not a maximum or minimum), it is more efficient to use either the cursor search functions (available on the HP 8757D only) or to read the entire trace and search for the points you need.

Program 4 listing

```

10  PRINTER IS 1
20  Start_freq=.01
30  Stop_freq=20
40  ASSIGN @Sna TO 716
50  ASSIGN @Passthru TO 717
60  ABORT 7
70  CLEAR @Sna
80  OUTPUT @Sna;"IP"
90  OUTPUT @Sna;"PT19"
100 OUTPUT @Passthru;"FA";Start_freq;"GZ
    FB";Stop_freq;"GZ"
105 OUTPUT@Sna
110 OUTPUT @Sna;"C2 CXOC"
120 ENTER @Sna;Value,Posn
130 PRINT "Cursor reads ";Value;"dB at position";Posn
140 INPUT "Desired cursor position (0..400)?",New_posn
150 OUTPUT @Sna;"SC";INT(New_posn+.5)
160 OUTPUT @Sna;"OC"
170 ENTER @Sna;Value,Posn
180 PRINT "Value at position";Posn;"is ";Value;"dB."
190 INPUT "Cursor frequency (GHz)?",Cur_freq
200 New_posn=400*((Cur_freq-Start_freq)/(Stop_freq-
    Start_freq))
210 OUTPUT @Sna;"SC";INT(New_posn+.5)
220 OUTPUT @Sna;"OC"
230 ENTER @Sna;Value,Posn
240 Cur_freq=Start_freq+(Stop_freq-Start_freq)*(Posn/400)
250 PRINT "Cursor reads ";Value;"dB at";Cur_freq;"GHz."
260  END

```

Program 4 explanation

- | | |
|---------|--|
| Line 10 | Direct the printed output to the computer CRT. |
| Line 20 | Define the start frequency of the desired sweep in GHz. |
| Line 30 | Define the stop frequency of the desired sweep in GHz. |
| Line 40 | Assign an I/O path to the address of the analyzer. |
| Line 50 | Assign an I/O path to the passthru address of the analyzer. |
| Line 60 | Abort any transfers and clear the HP-IB interface of the computer. |
| Line 70 | Clear the HP-IB interface of the analyzer. |

Line 80 Preset the analyzer and source. This sets the number of points per trace to 401.

Line 90 Tell the analyzer which instrument is controlled through the passthru address (19 is the source).

Line 100 Command the source to set a start frequency of 0.01 GHz and a stop frequency of 20 GHz.

Line 105 Turn passthru mode off. Allow analyzer display to update.

Line 110 Set the cursor to the maximum point on channel 2 and command the analyzer to output the cursor's value and position.

Line 120 Read the value and position of the cursor.

Line 130 On the computer CRT, print the value and position of the cursor.

Line 140 Get the new cursor position from the user. Input should be between 0 and 400.

Line 150 Set the cursor to the new cursor position chosen by the user. The INT function truncates instead of rounding, so add 0.5 to the cursor position before making it an integer.

Line 160 Command the analyzer to output the cursor's value and position.

Line 170 Read the value and position of the cursor at its new position.

Line 180 Print the cursor's value and position on the computer CRT.

Line 190 Get the new cursor frequency from the user. It must be within the frequency range of the sweep selected.

Line 200 Calculate the position of the cursor from its frequency and the start and stop frequencies of the current measurement.

Line 210 Set the cursor to the desired position.

Line 220 Command the analyzer to output the cursor's value and position.

Line 230 Read the cursor's value and position.

Line 240 Calculate the cursor's actual frequency from its position and the start and stop frequencies of the current measurement. You can easily program other start and stop frequencies by following the example in program 3.

Line 250 On the computer CRT, print the value and actual frequency of the cursor.

Line 260 End program execution.

Running program 4

1. Clear the program memory of the computer and type in the program.
2. Press [RUN] on the computer.
3. The computer turns on both channels and sets channel 1 to reflection (input A) and channel 2 to transmission (input B). The cursor is positioned to the maximum point on the channel 2 trace, and its value and position are read and displayed. At preset, the number of points per trace is 401.
4. The computer displays the prompt:

Desired cursor position (0..400)?

Type in a number between 0 and 400 and press [Continue]. A position of 0 represents the left side of the analyzer's CRT (lowest frequency) and 400 represents the right side of the CRT (highest frequency). The position is set, and the cursor's value and position are read and printed on the CRT of the computer.

5. The computer stops and displays the prompt:

Cursor frequency (GHz)?

Enter a frequency within the current start and stop frequencies of the measurement (0.01 to 20 GHz). The nearest cursor position is calculated and set. The cursor's value and position are read, and the actual cursor frequency is calculated from the cursor's position.

Note: The original desired frequency and the actual cursor frequency are usually different. Because there are only 401 possible cursor positions, some frequencies cannot be set exactly.

To use more points per trace when using the HP 8757D, modify line 80 to be "IP SP801" for 801 points. Then modify "400" in lines 140, 200, and 240, to "800".

Program 5: read a single value

Measurements often require that a single value be read at a CW frequency, particularly when extremely good frequency accuracy and resolution are required.

The analyzer is able to read and send a single reading of any measurement channel, via HP-IB, to the computer. The OUTPUT VALUE (OV) command operates on the active channel and causes the analyzer to send one reading of measurement data. Even when the analyzer is in normalized mode (MEAS-MEM), the OV command sends the measured, not the normalized, data. This command, like the OUTPUT DATA command in program 6, can operate with either ASCII or fast binary formats.

Program 5 listing

```

10  PRINTER IS 1
20  ASSIGN @Sna TO 716
30  ASSIGN @Passthru TO 717
40  ABORT 7
50  CLEAR @Sna
60  OUTPUT @Sna;"IP"

```

```

70 OUTPUT @Sna;"PT19"
80 OUTPUT @Sna;"SW0"
90 Freq=2
100 Freq_step=.1
110 OUTPUT @Passthru;"CW";Freq;"GZ SF";Freq_step;"GZ"
120 OUTPUT @Sna;"C1IA"
130 FOR I=1 TO 21
140   OUTPUT @Sna;"OV"
150   ENTER @Sna;Value
160   PRINT I;" ",Value;"dB at";Freq;"GHz"
170   OUTPUT @Passthru;"CW; UP"
180   Freq=Freq+Freq_step
190 NEXT I
200 OUTPUT @Passthru;"FA2GZ FB4GZ"
210 OUTPUT @Sna;"SW1"
220 END

```

Program 5 explanation

Line 10 Direct the printed output to the computer CRT.

Line 20 Assign an I/O path to the address of the analyzer.

Line 30 Assign an I/O path to the passthru address of the analyzer.

Line 40 Abort any transfers and clear the HP-IB interface of the computer.

Line 50 Clear the HP-IB interface of the analyzer.

Line 60 Preset the analyzer and source.

Line 70 Tell the analyzer which instrument is controlled through the passthru address (19 is the source).

Line 80 Put the analyzer in non-swept mode. This step is necessary when you read single values. After receiving this command, the analyzer stops updating its display.

Line 90 Define a start frequency for further measurements (in GHz).

Line 100 Define a frequency increment (in GHz).

Line 110 Put the source into CW mode at the start frequency, and set its frequency step size to that of the frequency increment.

Line 120 Command the analyzer to measure reflection (input A) on channel 1. This statement also causes the analyzer to exit passthru mode.

Line 130 Make 21 measurements, at equally spaced CW frequencies.

Line 140 Command the analyzer to send the current reading of channel 1 (the active channel) to the computer. The reading is taken immediately.

Line 150 Read the value. In this instance, no format has been defined so the default format of ASCII is in effect.

Line 160 Print the measurement number, the reading, and the frequency on the computer CRT.

Line 170 Command the source to increment the CW frequency by the step size set earlier (line 90). This is a very fast way of setting a series of equally spaced frequencies.

Line 180 Increment the variable that contains the current frequency. This variable is only used for printing the current frequency at each repetition of the loop.

Line 190 End of the loop.

Line 200 Command the source to sweep from 2 to 4 GHz. The source exits CW mode and returns to start/stop mode.

Line 210 Command the analyzer to return to swept mode. The analyzer again updates the trace information on the CRT. This command also exits passthru mode.

Line 220 End program execution.

Running program 5

1. Clear the program memory of the computer and type in the program.
2. Press [RUN] on the computer.
3. The source frequency is set immediately to 2 GHz and the computer begins reading reflection (input A) on the analyzer and printing the measurements. After 21 readings, the program ends.

Program 6: trace transfer

One feature that sets the HP 8757D/E apart is its ability to transfer an entire measurement trace to a computer at very high speed. A complete, high-resolution (0.01 dB), 401-point measurement can be sent to the computer in 35 milliseconds (binary format) or 800 milliseconds (ASCII format). Transfer time will be less for fewer points per trace, and greater for more points per trace.

The analyzer gives you complete flexibility when reading measurement traces via HP-IB. You can read from the active channel and you can read the stored memory trace, the current measurement trace, or the normalized trace (measurement-minus-memory). In addition, the memory trace can be written back to the analyzer, allowing you to save and restore calibration traces via HP-IB.

With trace transfer measurements, some frequency resolution is sacrificed for measurement speed. The number of points per trace can be programmed to control the resolution across the frequency range being swept. If you are measuring a device that changes very rapidly with frequency, it is possible to miss very narrowband responses that occur between measurement points if the resolution is low. For these cases, the measurement should be made at a higher resolution. The trace transfer method of measurement is much faster than CW point-by-point measurements.

Program 6 listing

```

10  ASSIGN @Sna TO 716
20  ASSIGN @Fast_sna TO 716;FORMAT OFF
30  ABORT 7
40  CLEAR @Sna
50  OUTPUT @Sna;"IP"
60  DIM Ascii_dat(0:400)
70  INTEGER Bin_dat(0:400)
80  OUTPUT @Sna;"C1LA C2IB"
90  WAIT 1
100 OUTPUT @Sna;"FD0 C1OD"
110 ENTER @Sna;Ascii_dat(*)
120 OUTPUT @Sna;"C1WM";Ascii_dat(*)
130 PAUSE
140 OUTPUT @Sna;"FD1 C2OD"
150 ENTER @Fast_sna;Bin_dat(*)
160 OUTPUT @Sna USING "#,K";"C2WM"
170 OUTPUT @Fast_sna;Bin_dat(*)
180 PAUSE
190 FOR I=0 TO 400
200   Bin_dat(I)=(IMOD 100)
210 NEXT I
220 OUTPUT @Sna;"C2C0 C1MY"
230 OUTPUT @Sna USING "#,K";"FD1 WM"
240 OUTPUT @Fast_sna;Bin_dat(*)
250 OUTPUT @Sna;"AS"
260 END

```

Program 6 explanation

Line 10 Assign an I/O path to the address of the analyzer.

Line 20 Assign another I/O path to the address of the analyzer, to be used for fast binary transfers.

Line 30 Abort any transfers and clear the HP-IB interface of the computer.

Line 40 Clear the HP-IB interface of the analyzer.

Line 50 Preset the analyzer and the source. This sets the number of points per trace to 401.

Line 60 Dimension an array to hold a trace in ASCII format. An array is 401 elements (0 to 400, inclusive).

Line 70 Dimension an array to hold a trace in binary-format. It is also 401 elements.

Line 80 Set channel 1 to reflection (input A) and channel 2 to transmission (input B).

Line 90 Wait for the source to sweep a few times, to insure the traces contain valid data. When you command the analyzer to output a trace, it responds immediately.

Line 100 Set the format to ASCII and command the analyzer to output the channel 1 measurement trace data.

Line 110 Read the measurement trace. Note the use of an asterisk (*) to designate the entire array.

Line 120 Write the measured trace back to the trace memory of channel 1. Reading the measurement trace and storing it into the memory trace is equivalent to executing the MEAS_MEM function (SM).

Line 130 Temporarily stop program execution.

Line 140 Set the format to binary and command the analyzer to output its channel 2 measurement trace.

Line 150 Enter the measurement trace through the I/O path that suspends formatting. This technique is useful for reading data from the analyzer at the highest possible speed.

Line 160 Command the analyzer to accept the trace into its channel 2 memory. Note the suppression of the normal carriage return/line feed sequence by the "#,K" format. If the cr/lf isn't suppressed, the analyzer assumes the first data point is null.

Line 170 Send the trace to the analyzer, again through the I/O path that suspends formatting.

Line 180 Temporarily stop program execution.

Line 190 Set up a loop for all 401 measurement points read from the analyzer.

Line 200 Calculate an arbitrary function and fill the binary data array. This function has no particular meaning, but represents some special calibration data (such as a short/open average).

Line 210 End of the loop.

Line 220 Turn off channel 2 and command channel 1 to display the trace memory data.

Line 230 Set the format to binary (redundant, but good practice) and command the analyzer to accept the following trace to channel 1 memory. Again, suppress the cr/lf sequence at the end of the line.

Line 240 Write the trace to the memory through the I/O path that suspends formatting.

Line 250 Command the analyzer to autoscale the current display, which is the memory trace just written.

Line 260 End program execution.

Running program 6

1. Clear the program memory of the computer and type in the program.
2. Press [RUN] on the computer.
3. Watching the analyzer CRT, you will see **DATA DUMP TO HP-IB** when it begins sending trace data to the computer, and **DATA DUMP TO TRACE MEMORY** when the computer sends the data back. The transfer takes about 800 milliseconds each way (ASCII transfer).
4. Watching the analyzer CRT, press [Continue] on the computer. The computer again reads and writes a trace of data, and the analyzer displays the same messages. The transfer is very fast, about 35 milliseconds each way (binary format).
5. Press [Continue] on the computer. The computer calculates an arbitrary function and sends it to a trace memory of the analyzer, where it is autoscaled and displayed. This function (a sawtooth pattern) has no significance. It represents a special calibration trace, such as a short/open average. With a computer, the analyzer measurement system may be calibrated over several different frequency ranges and changed from one to another very quickly, without re-calibration.

When writing memory traces in ASCII format, be sure to set the analyzer to ratio or single-input measurements before sending the trace. If you wish to transfer a higher resolution trace, modify line 50 to be "IP SP801" for 801 points. Then modify the "400" in lines 60, 70, and 190, to "800".

Program 7: using the TAKE SWEEP command

To make measurements as quickly and efficiently as possible, it is often necessary to synchronize the source with the analyzer. The TAKE SWEEP command gives the analyzer the ability to command the source to make a specified number of complete sweeps (1 to 255). This command is especially useful when using the trace transfer method of reading data from the analyzer.

To use the TAKE SWEEP command, place the analyzer in non-swept mode (SW0). Then give the TAKE SWEEP command with the number of sweeps desired (Tsd). At the end of the specified number of sweeps, the analyzer informs the computer of the completion of this operation by setting a bit in its status byte.

The computer can detect this event in two ways:

- Monitor the status byte continuously until the bit is set (polling).

- Let the analyzer generate a service request (SRQ) and interrupt the computer.

Table 1 is a diagram of the status bytes of the analyzer. It shows all of the bits that can be used to either monitor or interrupt the computer. In this program, bit 4 (decimal value 16) is used to signal operation complete (all of the sweeps specified by the TAKE SWEEP command have been completed.)

When you follow the take sweep command with an output statement, such as OUTPUT DATA (OD), the data is sent immediately, not after the instructed number of sweeps. The two approaches mentioned overcome this by letting us send the data at the end of the specified number of sweeps, not immediately. A third approach is to use the sweep hold mode (SW2) instead of the non-swept mode (SW0). In this mode the analyzer will prevent any HP-IB operations until the completion of the TAKE SWEEP command.

Program 7 listing

```
10 DIM Ascii_dat(0:400)
20 ASSIGN @Sna TO 716
30 ASSIGN @Passthru TO 717
40 ABORT 7
50 CLEAR @Sna
60 OUTPUT @Sna;"IP"
70 OUTPUT @Sna;"PT19"
80 OUTPUT @Passthru;"ST250MS"
90 OUTPUT @Sna;"C2C0 IB"
100 OUTPUT @Sna;"SW0 CS RM16"
110 OUTPUT @Sna;"TS10"
120 Stat=SPOLL(@Sna)
130 IF BIT(Stat,4)=0 THEN 120
140 OUTPUT @Sna;"C1OD"
150 ENTER @Sna;Ascii_dat(*)
160 OUTPUT @Sna;"SW1"
170 PAUSE
180 OUTPUT @Sna;"SW0 CS RM16"
190 ON INTR 7 GOTO Srq_recv
200 ENABLE INTR 7;2
210 OUTPUT @Sna;"TS10"
220 GOTO 220
230 Srq_recv: !
240 Stat=SPOLL(@Sna)
250 OUTPUT @Sna;"RM0"
260 OUTPUT @Sna;"C1OD"
270 ENTER @Sna;Ascii_dat(*)
280 OUTPUT @Sna;"SW1"
290 END
```

Program 7 explanation

- Line 10 Dimension an array large enough to hold a trace of data (401 points).
- Line 20 Assign an I/O path to the address of the analyzer.
- Line 30 Assign an I/O path to the passthru address of the analyzer.

Line 40 Abort any transfers and clear the HP-IB interface of the computer.

Line 50 Clear the HP-IB interface of the analyzer.

Line 60 Preset the analyzer and source.

Line 70 Tell the analyzer which device is controlled through the passthru address. Address 19 belongs to the sweeper.

Line 80 Set the source to 250 milliseconds per sweep.

Line 90 Turn off channel 2 of the analyzer and select transmission (input B) for display on channel 1.

Line 100 Put the analyzer into non-swept mode. Clear the status register of the analyzer. Set the request mask to 16 (bit 4) so that the analyzer will set bit 4 ("operation complete") at the completion of the TAKE SWEEP command. Table 1 has a description of all bits in the status bytes.

Line 110 Command the analyzer to take 10 sweeps.

Line 120 Wait for the 10 sweeps to be completed by reading the analyzer status byte.

Line 130 Test the status byte to see if bit 4 is set. If it is, then 10 sweeps have been completed. If bit 4 is not set, then continue to read and test the status byte until it is set.

Line 140 Command the analyzer to output the channel 1 trace data.

Line 150 Read the trace data.

Line 160 Return the analyzer to swept mode. The display now updates continuously.

Line 170 Temporarily stop program execution.

Line 180 Put the analyzer into non-swept mode. Clear the status register of the analyzer. Set the request mask to 16 (bit 4, OPERATION COMPLETE) so that the analyzer will send the computer a service request (SRQ) at the completion of the TAKE SWEEP command. This is the same as in line 100 except we will look for interrupts this time.

Line 190 Define the routine to be executed when the SRQ is received from the analyzer. The label "Sr_q_rcv" is equivalent to line 230.

Line 200 Turn on interrupts in the computer. Specifically, allow an HP-IB service request to interrupt the computer. See the BASIC Language Reference of the computer for more detail about HP-IB programming.

Line 210 Command the analyzer to take 10 sweeps.

Line 220 Wait for the SRQ from the analyzer by putting the computer into a tight loop. If a PAUSE statement were used, the computer would not respond to interrupts.

Line 230 The computer begins execution here after receiving the SRQ from the analyzer.

Line 240 Read the status byte of the analyzer. This action clears the SRQ flag of the analyzer.

Line 250 Disable interrupt generation from the analyzer.

Line 260 Command the analyzer to output the channel 1 data trace.

Line 270 Read the channel 1 trace.

Line 280 Return the analyzer to swept mode. The analyzer display begins updating continuously.

Line 290 End of execution.

Running program 7

1. Clear the program memory of the computer and type in the program.
2. Press [RUN] on the computer.
3. The computer first presets the analyzer and source. It then sets the source to 250 milliseconds per sweep, and sets the analyzer to display transmission on channel 1.
4. The computer commands the analyzer to take 10 sweeps and polls the analyzer status byte to determine when they were completed. The computer reads a trace from the analyzer. Just before the trace is sent, you should see the display "freeze" as the TAKE SWEEP command is completed.
5. Press [Continue], and the computer again tells the analyzer to take 10 sweeps. This time the computer receives an interrupt after the last sweep. The computer sits in a loop (line 220) and waits until the analyzer signals completion of the TAKE SWEEP command. In this segment of the program, you should not see the display "freeze" at all. Immediately after it receives the interrupt, the computer puts the analyzer back into swept mode. This method of sensing the end of a TAKE SWEEP command via an interrupt is more time-efficient than the polling method previously used because the computer can be doing something else during the 10 sweeps.

Table 1. HP 8757D/E Status Byte Descriptions

STATUS BYTE (#1)								
BIT #	7	6	5	4	3	2	1	0
Decimal Value	128	64	32	16	8	4	2	1
Function	N/A	Request Service (SRQ)	SRQ on HP-IB Syntax Error	SRQ on Operation Complete (Sweep, Plot or Print)	SRQ on Softkey Only Pressed	SRQ on Change in Extended Status Byte	SRQ on Numeric Entry Completed (HP-IB or Front Panel)	SRQ on Any Front Panel Key Pressed
EXTENDED STATUS BYTE (#2)								
BIT #	7	6	5	4	3	2	1	0
Decimal Value	128	64	32	16	8	4	2	1
Function	N/A	SRQ on Detector Uncal	SRQ on Front Panel Preset or Power-on	SRQ on Limit Test Failed ¹	SRQ on Action Requested not possible	SRQ on Knob Activity	SRQ on Operation Failed ¹	SRQ on Self Test Failure

1. HP 8757D only.

To use the sweep hold mode, modify line 100 to "SW2" and delete lines 120 and 130. The program will wait at line 140 until the 10 sweeps are completed. Whenever practical, use the service request interrupt to sense the end of a TAKE SWEEP command. In fact, you can use the time to do plotting or printing of data, instead of sitting in a loop. Service requests are also useful for other events, as demonstrated by the next program.

Program 8: programming the softkeys

The analyzer has eight screen-labeled softkeys that make your measurements faster and easier. Under HP-IB control, you can re-label the softkeys with any annotation and sense when they are pressed.

Use the softkeys to branch to special measurement programs. By making full use of the softkeys, your automatic system may not need a normal computer keyboard at all, making it as easy to use as a manual instrument.

Program 8 listing

```

10  PRINTER IS 1
20  ASSIGN @Sna TO 716
30  ABORT 7
40  CLEAR @Sna
50  OUTPUT @Sna;"IP"
60  OUTPUT @Sna;"CS RM8"
70  ON INTR 7 GOTO Srq_recv
80  OUTPUT @Sna;"WK1 CAL 1"
90  OUTPUT @Sna;"WK2 TEST 1"
100 OUTPUT @Sna;"WK3 CAL 2"
110 OUTPUT @Sna;"WK4 TEST 2"
120 OUTPUT @Sna;"WK8 ABORT"

```

```

130 Wait_srq: !
140  ENABLE INTR 7;2
150  GOTO 150
160 Srq_recv: !
170  Stat=SPOLL(@Sna)
180  OUTPUT @Sna;"OK"
190  ENTER @Sna;Key code
200  SELECT Key code
210    CASE =32
220      PRINT "Calibration #1"
230    CASE =8
240      PRINT "Test #1"
250    CASE =0
260      PRINT "Calibration #2"
270    CASE =16
280      PRINT "Test #2"
290    CASE =41
300      PRINT "Abort measurement"
310      GOTO 360
320    CASE ELSE
330      PRINT "**** undefined ****"
340  END SELECT
350  GOTO Wait_srq
360  END

```

Program 8 explanation

Line 10 Direct output to the CRT of the computer.
 Line 20 Assign an I/O channel to the address of the analyzer.
 Line 30 Abort any transfers and clear the HP-IB interface of the computer.
 Line 40 Clear the HP-IB interface of the analyzer.
 Line 50 Preset the analyzer and source.

Line 60 Set the request mask to interrupt the computer whenever a softkey is pressed (bit 3). See Table 1 for the description of the status bytes.

Line 70 Define the line that the computer will go to whenever it receives an interrupt.

Line 80 Label softkey 1 with "CAL 1". Softkey 1 is the softkey at the top of the CRT.

Line 90 Label softkey 2 with "TEST 1".

Line 100 Label softkey 3 with "CAL 2".

Line 110 Label softkey 4 with "TEST 2".

Line 120 Label softkey 8 with "ABORT".

Line 130 Line label for routine that waits for an interrupt.

Line 140 Turn on the SRQ interrupts in the computer.

Line 150 Wait for the interrupt in a tight loop. If PAUSE were used, the interrupts would not be active.

Line 160 Line label for the routine that services the interrupts.

Line 170 Serial poll the analyzer. Reading the status byte of the analyzer clears the SRQ. The CLEAR STATUS (CS) command could also be used.

Line 180 Command the analyzer to output the key code of the last key pressed.

Line 190 Read the key code.

Line 200 Multi-way branch on key code value.

Line 210 If the key code is 32, then softkey 1 was pressed.

Line 220 Print an appropriate message.

Line 230 If the key code is 8, then softkey 2 was pressed.

Line 240 Print an appropriate message.

Line 250 If the key code is 0, then softkey 3 was pressed.

Line 260 Print an appropriate message.

Line 270 If the key code is 16, then softkey 4 was pressed.

Line 280 Print an appropriate message.

Line 290 If the key code is 41, then softkey 8 was pressed.

Line 300 Print an appropriate message.

Line 310 Exit the program by jumping to the end.

Line 320 If the key code doesn't match any of the preceding codes, another key was pressed. In this case, the key code has to be for softkey 5, 6, or 7 (key codes 14, 38, or 40) since these are the only other keys that can interrupt the computer.

Line 330 Print an appropriate message.

Line 340 End of multi-way branch.

Line 350 Re-enter the program at the "Wait_srq" label. At that point, the interrupts are re-enabled and the computer waits for another SRQ.

Line 360 End program execution.

Running program 8

1. Clear the program memory of the computer and type in the program.
2. Press [RUN] on the computer.
3. After the computer presets the analyzer and source, it writes the softkey labels on the analyzer CRT. When the first key label is written, the analyzer labels it and blanks the other softkey labels. Since all labels except softkeys 5, 6, and 7 are given new labels, softkeys 5, 6, and 7 remain blank.
4. Press any key on the analyzer except the [ABORT] softkey. Pressing a softkey causes a message to be printed on the CRT of the computer. Note that softkeys 5, 6, and 7 generate an interrupt, even though they weren't labeled. No other keys of the analyzer generate an interrupt, because of the SRQ mask specified. Because the analyzer is in remote mode, nothing is changed by pressing its keys.
5. Press the [ABORT] softkey to end program execution.

In this example, the service request mask was set to interrupt the computer whenever a softkey was pressed. Another bit in the mask causes an interrupt to be generated when any key is pressed.

Because the analyzer was left in remote mode, it didn't respond to any keys pressed on its front panel. In some applications it is useful to put the analyzer into local operation, so that it can be controlled from the front panel and still generate interrupts whenever a key is pressed.

Program 9: CRT graphics

For applications requiring diagrams, drawings, or limit lines, the CRT of the analyzer may be written to as if it were a Hewlett-Packard plotter. By defining the analyzer as the plot device used by the computer, you can even use the special plotting statements built into the computer, such as MOVE, DRAW, PEN, AXES, VIEWPORT, etc.

This program draws a connections diagram for a hypothetical test system measuring an amplifier. It will blank the analyzer's standard display containing the graticule, annotation, and softkeys so that we have a blank CRT. Figure 2 shows what the CRT should look like when the program is done. Since the program involves drawing many lines, it will use the BASIC data statement to more efficiently store where to draw lines.

For fast, easy-to-use graphics, the graphics memory of the HP 8757D/E is divided into seven "pages" of 500 words and an eighth page of 4000 words. One vector requires two words. Each of the pages may be selected to receive data, and be turned on and off independently. You can keep different drawings in each of the graphics memory pages and simply turn on the drawing you need by turning on the appropriate page. Each page may also be erased independently.

To use the graphics capability of the HP 8757D/E, first define the passthru address to be one digit less than the analyzer's control address. If the analyzer's address is 16, its graphics address is 15. To the computer, the CRT of the analyzer looks like a plotter connected to the 8757 SYSTEM INTERFACE.

CONNECTION DIAGRAM

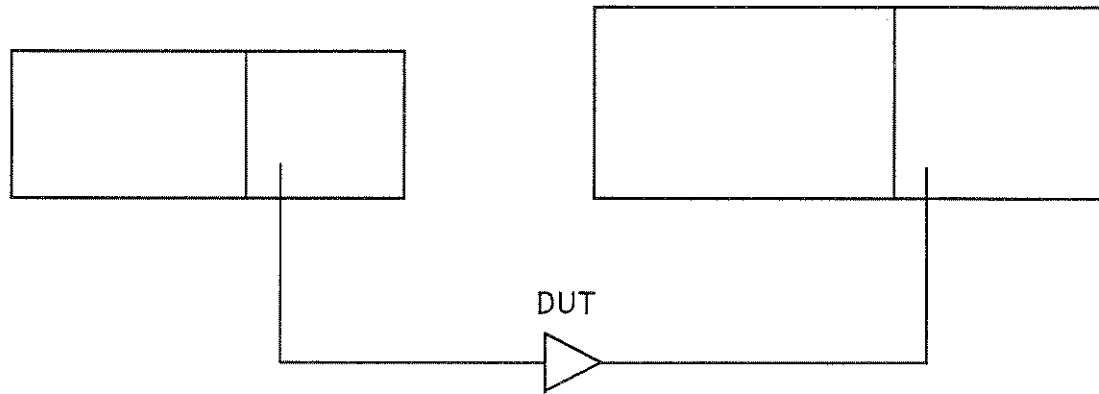

Figure 2. The CRT Graphics Display

Program 9 listing

```

10  ASSIGN @Sna TO 716
20  ASSIGN @Passthru TO 717
30  ABORT 7
40  CLEAR @Sna
50  OUTPUT @Sna;"IP BL5 PT15"
60  GINT
70  PLOTTER IS 717,"HPGL"
80  WINDOW 0,2924,0,2047
90  CLIP 0,2900,0,2000
100 OUTPUT @Passthru;"EP; GP1,1; DF"
110 PEN 3
120 GRID 100,100
130 PEN 10
140 RESTORE Graphix
150 REPEAT
160   READ Pen_mode$,X,Y
170   SELECT Pen_mode$
180     CASE "D"
190       DRAW X,Y
200     CASE "M"
210       MOVE X,Y
220   END SELECT
230 UNTIL Pen_mode$="E"
240 MOVE 600,1600
250 OUTPUT @Passthru USING "K";"SI0.28,0.34;
    LBCONNECTION DIAGRAM";CHR$(3)
260 MOVE 1200,250
270 LABEL "DUT"
280 Graphix: !

```

```

290 DATA "M",300,800,"D",1100,800,"D",1100,1100,
    "D",300,1100
300 DATA "D",300,800,"M",800,800,"D",800,1100
310 DATA "M",1500,800,"D",2300,800,"D",2300,1200,
    "D",1500,1200
320 DATA "D",1500,800,"M",1950,800,"D",1950,1200
330 DATA "M",875,850,"D",875,500,"D",1200,500
340 DATA "M",1400,500,"D",2050,500,"D",2050,850
350 DATA "M",1200,400,"D",1400,500,"D",1200,
    600,"D",1200,400
360 DATA "E",0,0
370 END

```

Program 9 explanation

- Line 10 Assign an I/O path to the address of the analyzer.
- Line 20 Assign an I/O path to the passthru address of the analyzer.
- Line 30 Abort any transfers and clear the HP-IB interface of the computer.
- Line 40 Clear the HP-IB interface of the analyzer.
- Line 50 Preset the analyzer and blank the CRT display. Define the CRT graphics as the target of passthru commands. The graphics address is always one less than the analyzer's HP-IB address.
- Line 60 Initialize the graphics. This sets a default line type, scale, and clipping limits in the computer.

- Line 70 Define the analyzer CRT as the plot device and tell the computer that it is an HP-GL (Hewlett-Packard Graphics Language) device.
- Line 80 Scale the plotting area to the entire CRT. The numbers are the corners of the CRT (the CRT is described in the *Operating Reference*.)
- Line 90 Define the soft clip area to maintain a clean display.
- Line 100 Erase all graphics pages. Turn on graphics page 1 to ensure that the graphics start in it. Set the display to monochrome default colors.
- Line 110 Select to plot with pen 3, dim green.
- Line 120 Plot a grid on the CRT. These are 100 by 100 graphic units per square, giving you an indication of where the X and Y coordinates are on the CRT.
- Line 130 Select to plot with pen 10, the brightest intensity for the analyzer CRT.
- Line 140 Define where to start looking for data. Here we've indicated that the data starts at the line label "Graphix", which is line 280. This ensures that we always start at the right data statement.
- Line 150 Define the beginning of a loop.
- Line 160 Read three items from the data statement. "Pen_mode\$" is a one character string indicating whether we should move (M), draw (D), or end (E) the plotting. X and Y are the plotting coordinates.
- Line 170 Multi-way branch on the "Pen_mode\$" value.
- Line 180 If "Pen_mode\$" is "D", then we want to draw.
- Line 190 Draw to coordinates X,Y.
- Line 200 If "Pen_mode\$" is "M", then we want to move.
- Line 210 Move to coordinates X,Y.
- Line 220 End of multi-way branch.
- Line 230 End of the repeat loop. Repeat lines 160 through 220 again if "Pen_mode\$" isn't "E". If it was, then we are done plotting the data in the data statements.
- Line 240 Move the pen to title our display.
- Line 250 Title the display with the label "CONNECTION DIAGRAM". This shows one way to label the analyzer display by using its internal character set. To do this, we must first specify which set to use via the SI command. This specifies the width and height respectively of each character and is similar to the computer's CSIZE instruction. We indicate what the label is with the LB command and follow it with the label. We must terminate the label with an "end-of-text" (ETX) character (a byte equal to a binary 3.)
- Line 260 Move the pen to label our device under test (DUT).
- Line 270 Label the DUT using the computer's LABEL statement. Notice the difference between this label and the one generated in line 250. First, the intensity is less. Second, the characters look more round and smooth. This is because the computer generates each character by plotting several small strokes (more than the HP 8757D/E's internal CRT does for its characters.) This means that you will also use much more graphics memory than with the internal character set.
- Line 280 Define the start of the data statements containing our plotting information for all of the lines on the CRT. While these may be less legible than lots of MOVEs and DRAWs, it is more efficient programming.
- Line 290 This data statement draws the outline of the source.
- Line 300 This data statement draws the RF plug-in.
- Line 310 This data statement draws the outline of the analyzer.
- Line 320 This data statement draws the CRT of the analyzer.
- Line 330 This data statement draws the connections from the source to the DUT.
- Line 340 This data statement draws the connections from the DUT to the analyzer.
- Line 350 This data statement draws the DUT (an amplifier.)
- Line 360 This data statement indicates the end of our plotting. The X and Y values are needed here only for the read statement in line 160.
- Line 370 End program execution.

Running program 9

1. Clear the program memory of the computer and type in the program.
2. Press [RUN] on the computer.
3. After the analyzer and source are preset, the CRT will be blanked. First a grid is plotted on the CRT. While this isn't necessary for our connection diagram, it does give you a good indication of where the X and Y coordinates are on the analyzer's CRT.
4. All of the lines are plotted on the analyzer's CRT. These are just a sequence of MOVES and DRAWs as specified by the data statements. If brighter lines are desired, draw each line twice.
5. Finally the labeling is added. The label "CONNECTION DIAGRAM" is done using the analyzer CRT's internal character set. The "DUT" label uses the computer's character set. The significant differences are that while using the computer's LABEL statement is easier, it also takes a lot more graphics memory than the internal character set. This can become very important if you have several labels or want to have several hookup diagrams.

In this example, only graphics page 1 is used. You can independently control up to 7 separate pages of graphics information. If you write too much information into one page, it overflows into the next page.

When a graphics page is selected, the first location of memory that receives information (identified by the "pointer") is reset to the beginning of the page. Thus, as information is written into the page, the old information is destroyed. If we were plotting a line, this would appear as a new trace overwriting an old one.

Program 10: learning the instrument state

Being able to save a specific instrument state is helpful when it is needed several times in a test or measurement procedure. You can save the instrument state by manually logging the important analyzer and sweeper parameters, such as start/stop frequency, sweep time, number of trace points, scale per division, and display format, then re-input them at the appropriate time. A simpler approach is to save the instrument state in one of the nine internal save/recall registers of the analyzer/source combination, then recall it when needed.

You have two additional options with HP-IB: the interrogate function and the learn string. With the output interrogated parameter function (OP), you can selectively interrogate the values of all functions that have numeric values (such as frequency and number of trace points.) This function operates the same in both the analyzer and the source. It is illustrated in program 3 where the source start and stop frequencies are interrogated in lines 80 through 130.

For a more thorough approach, use the learn string functions of the analyzer and source. Learn string describes the present instrument state and is similar to one of the internal save/recall registers. For the analyzer, the learn string also includes all of the global parameters, but does not include limit line information. Once an instrument state is learned, the analyzer and source states can be restored at any later time. The following program demonstrates how to both learn and restore the instrument states of the HP 8757D and the HP 8350B Sweep Oscillator by using their learn string functions. If you use the HP 8757E or the HP 8340B or 8341B Synthesized Sweepers, perform the modification described at the end of "Program 10 Explanation".

Program 10 listing

```
10  OPTION BASE 1
20  DIM Lswpr${90},Lsna${150}
30  ASSIGN @Sna TO 716
40  ASSIGN @Passthru TO 717
50  ABORT 7
60  CLEAR @Sna
70  OUTPUT @Sna;"PT19;"
80  LOCAL @Sna
90  INPUT "SET UP SYSTEM, PRESS CONTINUE",AS
100 OUTPUT @Sna;"OL"
110 ENTER @Sna USING "#,300A";Lsna$
120 OUTPUT @Passthru;"OL"
130 ENTER @Passthru USING "#,90A";Lswpr$
140 OUTPUT @Sna;"IP"
150 INPUT "TO RESTORE SETUP, PRESS CONTINUE",AS
160 OUTPUT @Sna USING "2A,300A";"IL",Lsna$
170 OUTPUT @Passthru USING "2A,90A";"IL",Lswpr$
180 OUTPUT @Sna
190 LOCAL @Sna
200 END
```

Program 10 explanation

- Line 10 Define the first element of any array to be at index number 1.
- Line 20 Dimension two strings large enough to hold the learn strings of the source (90 bytes) and the analyzer (300 bytes).
- Line 30 Assign an I/O path to the address of the analyzer.
- Line 40 Assign an I/O path to the passthru address of the analyzer.
- Line 50 Abort any transfers and clear the HP-IB interface of the computer.
- Line 60 Clear the HP-IB interface of the analyzer.
- Line 70 Tell the analyzer which device is controlled through the passthru address. Address 19 belongs to the source.
- Line 80 Set the analyzer and source to local mode.

Line 90 Prompt the user to set up the system and wait for the Continue key press.

Line 100 Program the analyzer to output its learn string.

Line 110 Read the analyzer learn string into the string "Lsna\$". Notice the "#,150A" format. The HP 8757D learn string is 150 contiguous binary bytes that does not end with a cr/lf (since these could actually be part of the learn string information). The computer must read all 300 bytes and this format ensures that it will.

Line 120 Program the source to output its learn string.

Line 130 Read the source learn string into the string "Lswpr\$". Notice the "#,90A" format. As on line 110, the computer must read the entire source learn string. For the HP 8350B Sweep Oscillator, it is 90 bytes long.

Line 140 Preset the analyzer and source to clear the instrument states.

Line 150 Prompt the user and wait for the [Continue] key press.

Line 160 Program the analyzer to accept its learn string, then send the learn string. Notice the "2A,300A" format ensures that the IL command and the 300 bytes of the learn string are sent continuously. The HP 8757D expects the learn string to start immediately after the IL command.

Line 170 Program the source to accept its learn string, then send the learn string. Notice the "2A,90A" format. As on line 160, this ensures that the source learn string is sent properly.

Line 180 Re-address the analyzer to exit passthru mode and continue sweeping.

Line 190 Set the analyzer and source to local mode.

Line 200 End of execution.

Running program 10

1. Clear the program memory of the computer and type in the program.
2. Press [RUN] on the computer.
3. The computer stops and displays: **SET UP SYSTEM, PRESS CONTINUE.**
Adjust the analyzer and source to a preferred instrument state, then press [Continue] on the computer.
4. The computer will save the learn strings of both the analyzer and the source. After completing this, the analyzer and source will be preset to destroy your original instrument state.

5. The computer stops and displays: **TO RESTORE SETUP, PRESS CONTINUE.**

Press [Continue] on the computer. The computer will restore your original instrument state via the two learn strings. Verify on the displays of the analyzer and the source that your instrument state has been restored.

This example is designed to work with the HP 8757D, which has a learn string of 300 bytes, and the HP 8350B Sweep Oscillator, which has a learn string of 90 bytes. To modify the program to work with the HP 8757E, which has a learn string of 150 bytes, change the "300" in lines 20, 110, and 160 to "150". To modify the program to work with the HP 8340B and 8341B Synthesized Sweepers, which have learn strings 123 bytes in length, change the "90" in lines 20, 130, and 170 to "123".

Program 11: CRT graphics on the HP 8757D

As was illustrated by program 9, it is possible to utilize the CRT of the HP 8757D/E as a plotter. This program goes one step further by utilizing the CRT to create a simple connection diagram which can be recalled by the user, at any time, from the front panel of the analyzer.

This program draws the same hypothetical connection diagram as was drawn by program 9. It blanks most of the analyzer's standard display including the graticle and all annotation except the softkeys. In addition it adds one softkey under both the save and the recall hardkey menus. This softkey will allow the user to toggle the state of the CRT graphics off and on.

To use the graphics off/on capability of the analyzer, simply change "BL5" in line 50 of program 9 to "BLA" and make the necessary changes in the size of the background grid. These changes are illustrated in the following listing.

The same principle may be used to save to disk anything stored in the first seven pages of user graphics on the analyzer. By having the softkeys available, the user can store CRT graphics onto a disk for later recall.

Program 11 listing

```

10  ASSIGN @SNA TO 716
20  ASSIGN @PASSTHRU to 717
30  ABORT 7
40  CLEAR @Sna
50  OUTPUT @Sna;"IP BLA PT15"
60  GINIT
70  PLOTTER IS 717;"HPGL"
80  WINDOW 0,2924,0,2047
90  CLIP 0,2700,0,2000
100 OUTPUT @Passthru;"EP; GP1,1;DF"
110 PEN 3
120 GRID 100,100
130 PEN 10
140 RESTORE Graphix
150 REPEAT
160   READ Pen_mode$,X,Y
170   SELECT Pen_mode$

```



```

180     CASE "D"
190         DRAW X,Y
200     CASE "M"
210         MOVE X,Y
220     END SELECT
230     UNTIL Pen_mode$="E"
240     MOVE 600,1600
250     OUTPUT @Passthru USING
        "K";"SI0.28,0.34;LBCONNECTION DIA-
        GRAM";CHR$(3)
260     MOVE 1200,250
270     LABEL "DUT"
275     OUTPUT@Sna
280     LOCAL 7
290 Graphix: !
300     DATA
        "M",300,800,"D",1100,800,"D",1100,1100,"D",300,1100
310     DATA "D",300,800,"M",800,800,"D",800,1100
320     DATA
        "M",1500,800,"D",2300,800,"D",2300,1200,"D",1500,12
        00
330     DATA "D",1500,800,"M",1950,800,"D",1950,1200
340     DATA "M",875,850,"D",875,500,"D",1200,500
350     DATA "M",1400,500,"D",2050,500,"D",2050,850
360     DATA
        "M",1200,400,"D",1400,500,"D",1200,600,"D",1200,400
370     DATA "E",0,0
380     END

```

Program 11 explanation

Line 10 Assign an I/O path to the address of the analyzer.

Line 20 Assign an I/O path to the passthru address of the analyzer.

Line 30 Abort any transfers and clear the HP-IB interface of the computer.

Line 40 Clear the HP-IB interface of the analyzer.

Line 50 Preset the analyzer and blank all the CRT display except the softkeys. Define the CRT graphics as the target of passthru commands. The graphics address is always one less than the analyzer's HP-IB address.

Line 60 Initialize the graphics. This sets a default line type, scale, and clipping limits in the computer.

Line 70 Define the analyzer CRT screen as the plot device and tell the computer that it is an HP-GL (Hewlett-Packard Graphics Language) device.

Line 80 Scale the plotting area to the CRT screen, allowing space for the softkeys. The numbers are the corners of the CRT, as described in the analyzer's operating manual.

Line 90 Define the soft clip area to maintain a clean display.

Line 100 Erase all graphics pages. Turn on graphics page 1 on to ensure that the graphics start there.

Line 110 Select to plot with pen 3, the lowest intensity for the analyzer CRT.

Line 120 Plot a grid on the CRT. These are 100 by 100 squares, giving you an indication of where the X and Y coordinates are on the CRT.

Line 130 Select to plot with pen 1, the brightest intensity for the analyzer CRT.

Line 140 Define where to start looking for data. Here we've indicated that the data starts at the line label "Graphix", which is line 280. This ensures that we always start at the right data statement.

Line 150 Define the beginning of a loop.

Line 160 Read three items from the data statement. Pen_mode\$ is a one character string indicating whether we should move "M", draw "D", or end "E" the plotting. X and Y are the plot coordinates.

Line 170 Multi-way branch on the Pen_mode\$ value.

Line 180 If Pen_mode\$ is "D", then we want to draw.

Line 190 Draw to coordinates X,Y.

Line 200 If Pen_mode\$ is "M", then we want to move.

Line 210 Move to coordinates X,Y.

Line 220 End of multi-way branch.

Line 230 End of the repeat loop. Repeat lines 160 through 220 again if Pen_mode\$ isn't "E". If it was, then we are finished plotting the data in the data statements.

Line 240 Move the pen to title our display.

Line 250 Title the display with the label "CONNECTION DIAGRAM". This shows one way to label the analyzer display by using its internal character set. To do this, we must first specify which set to use via the "SI" command. This specifies the width and height respectively of each character and is similar to the computer's CSIZE instruction. We indicate what the label is with the "LB" command and follow it with the label. We must terminate the label with an "end-of-text" (ETX) character—a byte equal to a binary 3.

Line 260 Move the pen to label our device under test (DUT).

Line 270 Label the DUT using the computer's LABEL statement. Notice the difference between this label and the one generated in line 250. First, the intensity is less. Second, the characters look more round and smooth. This is because the computer generates each character by plotting several small strokes (more than the HP 8757D/E's internal CRT does for its characters). This means that you will also use much more graphics memory than with the internal character set.

Line 275 Exit from passthrough mode.

Line 280 Set the analyzer and the source to local mode.

Line 290 Define the start of the data statements containing our plotting information for all of the lines on the CRT. While these may be less legible than lots of MOVES and DRAWS, it is more efficient programming.

Line 300 This data statement draws the outline of the sweeper.

Line 310 This data statement draws the plug-in in the sweeper.

Line 320 This data statement draws the outline of the analyzer.

Line 330 This data statement draws the CRT of the analyzer.

Line 340 This data statement draws the connections from the sweeper to the DUT.

Line 350 This data statement draws the connections from the DUT to the analyzer.

Line 360 This data statement draws the DUT (an amplifier.)

Line 370 This data statement indicates the end of our plotting. The X and Y values are needed here only to keep the read statement in line 160 happy.

Line 380 End program execution.

Running program 11

1. Clear the program memory of the computer and type in the program.
2. Press [RUN] on the computer.
3. After the analyzer and source are preset, the CRT will be blanked except the softkeys. First a grid is plotted on the CRT. While this isn't necessary for our connection diagram, it does give you a good indication of where the X and Y coordinates are on the analyzer's CRT.

4. All of the lines are plotted on the analyzer's CRT. These are just a sequence of MOVES and DRAWS as specified by the data statements. If brighter lines are desired, draw each line twice, or select different pen numbers.
5. Finally the labeling is added. The label "CONNECTION DIAGRAM" is done using the analyzer CRT's internal character set. The "DUT" label was done using the computer's character set. The key differences are that while using the computer's LABEL statement is easier, it also takes a lot more graphics memory than the internal character set. This can become very important if you have several labels or want to have several hookup diagrams.

Program 12: reading disks from the HP 8757D

In many cases it may be necessary to manipulate data that was saved onto disk with the HP 8757D. This program can be used to read the data files and display the contents of those files on the computer's CRT display. No frequency information is read or displayed.

The CITIfile (Common Instrumentation Transfer and Interchange File) disk format is used on the data disks for the HP 8757D. This program reads in a single array of data from a CITIfile data disk. It then outputs the point number and the magnitude associated with that point.

In order to use this program you must have saved either memory or measurement data in files onto a disk with the HP 8757D. In addition this data needs to be stored in ASCII format in order for it to be read by the CITIfile routine.

Program 12 listing

```
10     INTEGER Intvar(1:30),Counter
20     REAL Data_pt(1:1601,1:2,1:1)
30     DIM Filename${30}
40     LINPUT "Name of file to read? ",Filename$
50     Read_citfile(Filename$,Data_pt(*),Intvar(*))
60     PRINT "POINT #REAL IMAG "
70     FOR Counter=1 TO Intvar(1)
80         PRINT Counter;TAB(10);Data_pt(Counter,1,1);
           TAB(24);Data_pt(Counter,2,1)
90     NEXT Counter
100    PRINT "Printed the data array from file ";Filename$;" "
110    PRINT "The file contained an array with ";Intvar(1);"
           data points."
120    END
130    SUB Read_citfile(Filename$,Data_pt(*),INTEGER
           Intvar(*))
140    INTEGER Done,Count1
150    ALLOCATE Current_line${256},Token_found${32}
160    ASSIGN @Disk TO Filename$
170    Done=0
180    REPEAT
190        ENTER @Disk;Current_line$
200        Current_line$=TRIM$(Current_line$)
```

```

210     GOSUB Get_next_token
220     IF (Token_found$ <> "") THEN
230         SELECT Token_found$
240         CASE "VAR"
250             FOR Count1=1 TO 2
260                 GOSUB Remove_one_word
270             NEXT Count1
280             Intvar(1)=VAL(Current_line$)
290         CASE "BEGIN"
300             ALLOCATE Dstring$(1:Intvar(1))[30]
310             ENTER @Disk;Dstring$(*)
320             FOR Count1=1 TO Intvar(1)
330                 Data_pt(Count1,1,1)=VAL(Dstring$(Count1))
340                 Data_pt(Count1,2,1)=VAL(Dstring$(Count1)
                    [POS(Dstring$(Count1),"")+1])
350             NEXT Count1
360             Done=1
370         END SELECT
380     END IF
390 UNTIL Done
400 SUBEXIT
410 Get_next_token: !
420     Space_pos=POS(Current_line$," ")
430     IF Space_pos=0 THEN
440         Token_found$=Current_line$
450         Current_line$=""
460     ELSE
470         Token_found$=Current_line$[1,Space_pos-1]
480         GOSUB Remove one word
490     END IF
500     RETURN
510 Remove_one_word:Current_line$=TRIMS
    (Current_line$[POS(Current_line$,"")+1])
520     RETURN
530 SUBEND

```

Program 12 Explanation

Line 10 Declare an integer variable and dimension an integer array for use within the program.

Line 20 Dimension a real array for data storage.

Line 30 Dimension and reserve memory for the filename string.

Line 40 Prompt for and, accept alphanumeric input from the keyboard and place it in the "Filename\$" string.

Line 50 Call the subprogram that reads the file named via line 40.

Line 60 Setup a header for the printout of data from the array read in by the "Read citifile" subprogram.

Line 70 Set up a counter to determine the number of points to be printed from the data array. Note that the length of the array is kept in "Intvar(1)". This value is returned from the "Read_citifile" subprogram call.

Line 80 Print the data point, the REAL component, and the IMAGINARY component. For a scalar analyzer the imaginary components are always presumed to be zero. It is illustrative here to point out that the most general means of storing data in all analyzers requires the inclusion of phase as well as magnitude data. This is accomplished by storing the linear REAL and IMAGINARY components of the measurements.

Line 90 Continue printing until the entire data array is completed.

Line 100 Print the name of the file just listed at the end of the listing.

Line 110 Finish the printout by printing the number of data points in the data array.

Line 120 End of the main program.

Line 130 Define a subprogram that can be used to input the data array for the file named by the user. This routine is written to be modular so that it can be easily adapted for use in other programs.

Line 140 Declare the INTEGER variables to be used in the subprogram.

Line 150 Dynamically allocate memory for string variables used in the subprogram.

Line 160 Assign an I/O path name to the mass storage file of interest. In this case it is the filename input by the user.

Line 170 Set the expression "Done" to zero. This will be used to determine if all data has been read into the data array.

Line 180 Define a loop which is repeated until the value for "Done" is greater than zero.

Line 190 Statement used to input data from the file of interest and assign the values entered to a string variable.

Line 200 This function is used to return the string stripped of all leading and trailing ASCII spaces.

Line 210 Call a subprogram used to locate the first word on the line.

Line 220 If the boolean expression within the parenthesis is evaluated as true then the following conditions are tested. In this case the expression can be set true by the "Get_next_token" subprogram.

Line 230 Provide for conditional execution of one of two program statements using the string expression.

Line 240 If the string expression is "VAR", then remove two words from the data array. This is done to locate a piece of data that specifies the length of the array to follow.

Line 250 Begin loop to remove two words.

Line 260 Call to subprogram which removes a word.

Line 270 Continue the loop until two words have been removed.

Line 280 Convert the string expression for the length of the data array into a numeric value that can be used in the program as a counter.

Line 290 If the string expression is "BEGIN" this signifies the beginning of the data array to be input.

Line 300 Dynamically allocate space for the data array to be input.

Line 310 Input the data from the file specified.

Line 320 Begin a loop which converts the data string to numeric data pairs.

Line 330 Convert a REAL data point from the string into a numeric value and store the numeric value in an array.

Line 340 Convert an IMAGINARY data point from the string into a numeric value. The data is listed in pairs, separated by a comma, with the REAL component preceding the IMAGINARY component.

Line 350 Proceed to the next data pair.

Line 360 After completing input of the data array, set "Done" greater than 0.

Line 370 Finish of the construct which allowed for the conditional execution of one of two cases.

Line 380 Complete IF THEN sequence.

Line 390 Check to see that "Done" is greater than 0.

Line 400 This statement is used to return from the subprogram at some point other than the SUB-END statement. It allows for more than one exit from a subprogram.

Line 410 Define a subprogram called by "Read_citifile" to locate the next "token". The tokens of interest to this program are "VAR" and "BEGIN".

Line 420 Locate the position of the next ASCII space within the data string.

Line 430 If the value returned for the position of the next ASCII space is 0, then the ASCII space character doesn't exist in the string being searched.

Line 440 Set the token to whatever is currently in the data string.

Line 450 Set the string to a null character.

Line 460 If the value returned is greater than zero, then perform the following operations.

Line 470 Remove keyword from the string and make it the current token.

Line 480 Increment the pointer along the data string.

Line 490 Complete IF ... THEN sequence.

Line 500 Return from the "Get_next_token" subprogram.

Line 510 Define a subprogram called by "Get_next_token" subprogram. Used to increment the pointer along the data string to the next word.

Line 520 Return from the "Get_next_token" subprogram.

Line 530 End of the "Read_citifile" subprogram.

Running Program 12

1. Clear the program memory of the computer and type in the program.
2. Press [RUN] on the computer.
3. The computer displays the prompt:
Name of file to read?
At the prompt enter the name of the ASCII data file to be read by the program then press [Continue]. The program will begin reading the file specified and display the data from the disk onto the CRT of the computer in a tabular format.
4. The data will be listed as linear values for both the real and the imaginary components.

Table 2. Alphabetical Listing of HP 8757D/E Programming Codes (1 of 3)

Code	Action	Code	Action
A0	Averaging off	CLS	Color list, salmon ¹
AB	A/B ratio measurement	CLW	Color list, white ¹
AC	A/C ratio measurement ²	CLY	Color list, yellow ¹
AFd	Averaging on and factor d	CN	Cursor to minimum
ANm	Adaptive Normalization on/off	COBd	Brightness adjust, one color ¹
AR	A/R ratio measurement	COCd	Color adjust, one color ¹
AS	Autoscale	COTd	Tint adjust, one color ¹
AZ2	Autozero the DC detectors once	CR	C/R ratio measurement ²
AZm	Autozero repeat on/off of the DC detectors	CS	Clear status bytes
BA	B/A ratio measurement	CTm	Auto system calibration on/off
BC	B/C ratio measurement ²	CUm	Cursor on/off
BFm	Plotter buffer on/off ³	CWm	CW mode on/off
BL0	Restore CRT to normal mode	CX	Cursor to maximum
BL1	Blank frequency labels (secure frequency mode, frequency labels cannot be restored)	DAd	Detector A amplitude offset set to d
BL2	Blank all labels	DBd	Detector B amplitude offset set to d
BL3	Blank active channel trace	DCd	Detector C amplitude offset set to d ²
BL4	Blank softkey labels	DEC	Set default colors ¹
BL5	Blank all (except user CRT graphics)	DFA	Set disk format to ASCII ¹
BL6	Blank title	DFB	Set disk format to binary ¹
BL7	Blank mode labels	DFE	Set Disk format to extended binary ¹
BL8	Blank the active entry area	DHm	Display Hold on/off of the active channel trace
BL9	Blank the limit lines	DIAd	Set disk HP-IB address ¹
BLA	Blank all (except user CRT graphics and softkeys)	DIUd	Set disk unit number ¹
BR	B/R ratio measurement	DIVd	Set disk volume number ¹
BTNd	Overall display brightness	DLF	Delete file from disk ¹
BW	Display the search bandwidth on the CRT ¹	DM0	All inputs set to DC detection
C0	Channel off	DM1	All inputs set to AC detection
C1	Channel 1 on/active	DN	Step down (decrement)
C2	Channel 2 on/active	DOAd	Measure Detector A amplitude offset
C3	Channel 3 on/active ¹	DOBd	Measure Detector B amplitude offset
C4	Channel 4 on/active ¹	DOCd	Measure Detector C amplitude offset ²
CA	C/A ratio measurement ²	DORd	Measure Detector R amplitude offset
CB	C/B ratio measurement ²	DRd	Detector R amplitude offset set to d
CC1	Set channel 1 color ¹	DS0	Display trace data in log magnitude
CC2	Set channel 2 color ¹	DS1	Display trace data in standing wave ratio (SWR) format
CC3	Set channel 3 color ¹	DTSTPAs	Enter stop frequency for detector A
CC4	Set channel 4 color ¹	DTSTPBs	Enter stop frequency for detector B
CDm	Cursor delta on/off	DTSTPCs	Enter stop frequency for detector C ²
CGL	Set labels color ¹	DTSTPRs	Enter stop frequency for detector R
CGN	Set background color ¹	DTSTRAs	Enter start frequency for detector A
CGR	Set grid color ¹	DTSTRBs	Enter start frequency for detector B
CGW	Set warning label color ¹	DTSTRCs	Enter start frequency for detector C ²
CL	Perform system configuration of detectors and channels	DTSTRRs	Enter start frequency for detector R
CLB	Color list, black ¹	EO	Enter measured detector amplitude offset
CLG	Color list, green ¹	ER0	Erase all save/recall registers
CLL	Color list, blue ¹	FAs	Start frequency label
CLR	Color list, red ¹	FBs	Stop frequency label
		FD0	Format data ASCII

1. HP 8757D only

2. HP 8757D Option 001 only

3. Revision 3.1 or above for HP 8757E.

Table 2. Alphabetical Listing of HP 8757D/E Programming Codes (2 of 3)

Code	Action	Code	Action
FD1	Format data binary (HP BASIC compatible)	MU3	Display the reference menu
FD2	Format data extended ASCII	MU4	Display the cursor menu
FD3	Format data binary (PC compatible)	MU5	Display the average menu
FD4	Format data extended binary (HP BASIC compatible)	MU6	Display the calibration menu
FD5	Format data extended binary (PC compatible)	MU7	Display the special menu
FR0	Logarithmic (dB) cursor format ³	MU8	Display the system menu
FR1	SWR cursor format ³	MY	Display memory data
FSm	Step sweep on/off ^{3,4}	MZ	Manual calibration of DC detectors
FTAm	Detector A frequency on/off	NSm	Non-standard sweep mode on/off
FTBm	Detector B frequency on/off	OC	Output cursor value
FTCm	Detector C frequency on/off ²	OD	Output trace data
FTRm	Detector R frequency on/off	OE1	Output error status of display channel 1
IA	Input A absolute power measurement	OE2	Output error status of display channel 2
IB	Input B absolute power measurement	OI	Output identity
IC	Input C absolute power measurement ²	OK	Output keycode of last key pressed
ILs	Input Learn string	OL	Output learn string
IND	Initialize disk format ¹	OM	Output memory data
IP	Instrument preset	ON	Output normalized (measurement —memory) data
IR	Input R absolute power measurement	OPDO	Output measured detector amplitude offset
IX	External ADC input (AUX) voltage measurement ¹	OPxx	Output interrogated parameter value xx= AF, BW, DA, DB, DC, DR, RL, RP, SD, SL, SO, SP, SR, SS, ST
LE	Erase limit lines for active channel ⁵	OR	Output rotary knob value (−32768 ≤ value ≤ +32767)
LFA	Load instrument information file from disk ¹	OS	Output status bytes
LFC	Load CRT graphics file from disk ¹	OT1m	Control output #1 on/off
LFD	Load data trace file from disk ¹	OT2m	Control output #2 on/off
LFF	Load measurement file from disk. ¹	OV	Output CW value
LFH	Load instrument information file from disk and place instrument in hold mode. ¹	P1	Plot channel 1 trace on external plotter
LFI	Load instrument state file from disk ¹	P2	Plot channel 2 trace on external plotter
LFM	Load memory trace file from disk ¹	P3	Plot channel 3 trace on external plotter ¹
LFN	Load display trace file from disk. ¹	P4	Plot channel 4 trace on external plotter ¹
LFs	Enter limit test flat line data ⁵	PA	Plot all on external plotter
LL	Store lower limit line into memory ⁵	PBm	System interface control on/off
LPs	Enter limit test point data ⁵	PC	Plot labels on external plotter
LSs	Enter limit test sloped line data ⁵	PD	Plot custom plot
LTm	Limit line test on/off ⁵	PG	Plot grid on external plotter
LU	Store upper limit line into memory ⁵	PR1	Print all to monochrome printer, except softkeys and CRT graphics
M-	Display normalized data (measurement — memory)	PR2	Print tabular display data in monochrome
MDm	Modulation on/off	PR3	Print tabular marker/cursor data to external printer
ME	Display measurement data	PR4	Print all to color printer, except softkeys and CRT graphics ¹
MM	Display the channel menu(main menu)	PTd	Passthrough address set to d
MN	Display normalized data (same as M-)	PWRA	Execute a detector A power calibration
MOC	Monochrome display ¹	PWRB	Execute a detector B power calibration
MR	Marker (or cursor) to reference line	PWRC	Execute a detector C power calibration ²
MSm	Manual sweep mode on/off	PWRR	Execute a detector R power calibration
MU0	Display the measurement menu	R1	R/A ratio measurement
MU1	Display the display menu	R2	R/B ratio measurement
MU2	Display the scale menu		

1. HP 8757D only

2. HP 8757D Option 001 only

3. Revision 3.1 or above for HP 8757E.

4. HP 8340, HP 8341, or HP 8360 series synthesized sweeper only with 8757 SYSTEM INTER-FACE connected and active.

5. Limit line functions valid only for channels 1 or 2. HP 8757D only.

Table 2. Alphabetical Listing of HP 8757D/E Programming Codes (3 of 3)

Code	Action	Code	Action
R3	R/C ratio measurement ²	SR	Cursor search right ¹
RCn	Recall register n	SSd	Cursor search value set to d ¹
RLd	Reference level set to d	STd	Reference level step size set to d
RMd	Service request mask set to d	SUd	Specify custom plot according to d
RPq	Reference position set to vertical division q	SVn	Save register n
RS	Restart averaging	SW0	Non-swept mode; non-swept operation
SCd	Set cursor to horizontal position d	SW1	Swept mode; normal swept operation
SDd	Scale per division set to d	SW2	Sweep hold mode; non-swept mode with HP-IB bus hold off until completion of TSd
SFA	Store all instrument information to disk in file ¹	TCm	Continuous Temperature Compensation on/off
SFC	Store CRT graphics to disk in file ¹	TIFs	Title for file ¹
SFD	Store data trace to disk in file ¹	TSd	Take d sweeps, then hold display
SFI	Store instrument state to disk in file ¹	UP	Step up (increment)
SFM	Store memory trace to disk in file ¹	WKs	Write softkey label
SFN	Store normalized trace to disk in file ¹	WMs	Write to channel memory.
SKq	Select softkey q: q = 1 to 8	WTs	Write title, s is an ASCII string of up to 50 characters
SL	Cursor search left ¹	XAs	External detector cal value for detector A
SM	Store measurement into memory	XBs	External detector cal value for detector B
SN	Store normalized data (measurement - memory) into memory	XCs	External detector cal value for detector C ²
SOd	Smoothing set to d % of frequency span	XR	External detector cal value for detector R
SPd	Number of points set to d: d=101, 201, 401, 801 ¹ , 1601 ¹		

1. HP 8757D only

2. HP 8757D Option 001 only (detector C)

NOTES: n = decimal integer 1 to 9
d = variable length numeric
m = 0 for off/1 for on
q = unique value
s = ASCII or binary string

For more information, call your local HP sales office listed in your telephone directory or an HP regional office listed below for the location of your nearest sales office.

United States:

Hewlett-Packard Company
4 Choke Cherry Road
Rockville, MD 20850
(301) 670-4300

Hewlett-Packard Company
5201 Tollview Drive
Rolling Meadows, IL 60008
(312) 255-9800

Hewlett-Packard Company
5161 Lankershim Blvd.
No. Hollywood, CA 91601
(818) 505-5600

Hewlett-Packard Company
2015 South Park Place
Atlanta, GA 30339
(404) 955-1500

Canada:

Hewlett-Packard Ltd.
6877 Goreway Drive
Mississauga, Ontario L4V1M8
(416) 678-9430

Australia/New Zealand:

Hewlett-Packard Australia Ltd.
31-41 Joseph Street,
Blackburn, Victoria 3130
Melbourne, Australia
(03) 895-2895

Europe/Africa/Middle East:

Hewlett-Packard S.A.
Central Mailing Department,
P.O. Box 529
1180 AM Amstelveen,
The Netherlands
(31) 20/547 9999

Far East:

Hewlett-Packard Asia Ltd.
22/F Bond Centre
West Tower
89 Queensway
Central, Hong Kong
(5) 8487777

Japan:

Yokogawa-Hewlett-Packard Ltd.
29-21, Takaido-Higashi 3-chome
Suginami-ku, Tokyo 168
(03) 331-6111

Latin America:

Latin American Region Headquarters
Monte Pelvoux Nbr. 111
Lomas de Chapultepec
11000 Mexico, D.F. Mexico
(905) 596-79-33

July 15, 1992

HP Part Number 08757-90116
Printed in U.S.A.



Addendum to HP-IB Programming Note HP 8757D/E with HP 9000 Series 200/300 computer (BASIC)

The following table provides additional codes for Table 2 of the HP-IB Programming Note, HP 8757D/E with HP 9000 Series 200/300 computer (BASIC).

Table 6-2. Alphabetical Listing of HP 8757D/E Programming Codes

Code	Action
DT	Set the date: day, month, year
OPDT	Output current date (ASCII string)
OPTM	Output current time (ASCII string)
TDM	Set time: hour, minute, second
TDM	Time stamp on/off

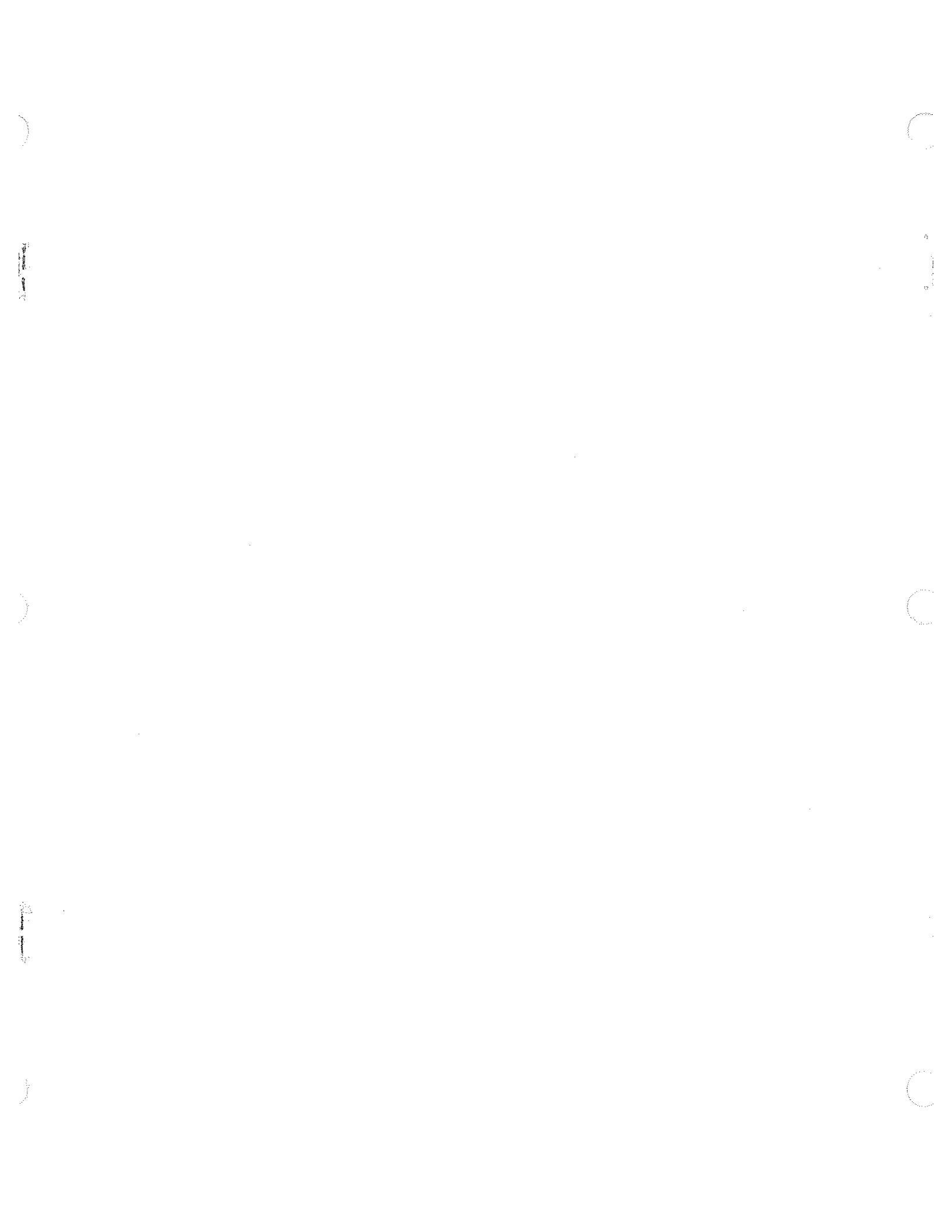

Introductory Programming Guide

For the HP 8757D/E scalar network analyzer with the HP Vectra Personal Computer using Microsoft® QuickBasic 4.5

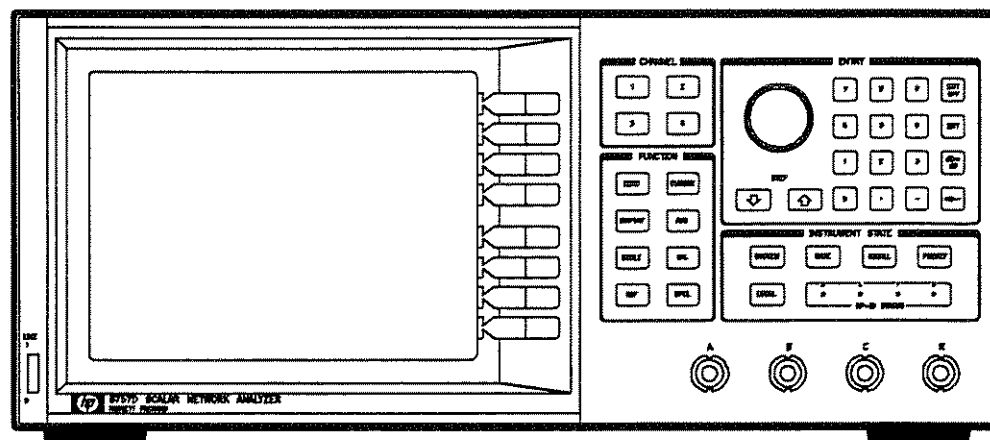

Introduction

This programming note describes the remote operation of the HP 8757D/E Scalar Network Analyzer with the HP Vectra Personal Computer (or IBM compatible) using the HP 82335A HP-IB Command Library and Microsoft QuickBASIC 4.5. Included in this guide are several short programs that demonstrate the use of the analyzer with HP-IB commands, and a diagram of system connections for remote control.

The HP 8757D/E is a fully programmable analyzer capable of making magnitude-only transmission and reflection measurements over an RF and microwave frequency range of 10 MHz to 100 GHz. When used with an HP-IB computer, the analyzer's front panel may be remotely controlled, along with most softkey functions and some functions accessible only via HP-IB. The analyzer exerts control over a source (HP 8350B, 8340B/41B, or 8360), digital plotter (HP 7440A or 7550A), and printer (HP 2225A ThinkJet, HP 3630A PaintJet, or HP 2227B QuietJet Plus) connected to the 8757 SYSTEM INTERFACE.

This note assumes you are familiar with local (non-remote) operation of the HP 8757D/E. If not, refer to the operating manual. You should also be familiar with the HP Vectra Personal Computer (or compatible), particularly HP-IB operation using the HP 82335A Command Library.

The following are sample programs included in this guide:

- Program 1: Remote, Local, and Local Lockout.
- Program 2: Controlling the Front Panel.
- Program 3: Passthru Mode.
- Program 4: Cursor Operations.
- Program 5: Read a Single Value.
- Program 6: Trace Transfer.
- Program 7: Using the TAKE SWEEP Command.
- Program 8: Programming the Softkeys.
- Program 9: CRT Graphics.
- Program 10: Learning the Instrument State.
- Program 11: Guided Instrument Setup with CRTGraphics.

Reference information

The following texts provide additional information on the HP Interface Bus, analyzer, source, and HP Vectra Personal Computer.

HP 8757D/E literature

- *HP 8757D Operating Manual.*
- *HP 8757C/E Operating Manual.*
- Programming Note: *Quick Reference Guide for the HP 8757D/E Scalar Network Analyzer.*

Source literature

- Programming Note: *Quick Reference Guide for the HP 8350B Sweep Oscillator.*
- Programming Note: *Quick Reference Guide for the HP 8340B Synthesized Sweeper.*
- *HP 8360 Operating and Programming Reference.*

HP Vectra Personal Computer literature

- *HP 82335A HP-IB Command Library Manual.*
- Microsoft QuickBASIC: BASIC Language Reference Manual.
- *Microsoft QuickBASIC: Learning and Using Microsoft QuickBASIC.*
- *Microsoft QuickBASIC: Programming in BASIC: Selected Topics.*

Equipment required

- 1 HP 8757D/E Scalar Network Analyzer.
- 1 HP 8350B Sweeper with plug-in, HP 8340B/41B Synthesized Sweeper, or HP 8360 series Synthesized Sweeper.
- 1 HP Vectra Personal Computer (or compatible) with Microsoft QuickBASIC 4.5, HP 82335A HP-IB Interface Card, MS-DOS 3.3 or higher, and at least 320K bytes of memory.
- 1 HP 85027A/B/C/D/E Directional Bridge.
- 1 HP 11664A/E Detector, HP 85025A/B/D/E Detector, or HP 85037A/B Precision Detector with connector type to match bridge and test device.
- 1 Shielded open circuit with connector to mate with bridge.
- 1 Short circuit with connector to mate with bridge.
- 3 HP 11170C BNC cables, 122 cm (48 in.). (4 are needed with HP 8340B/41B).
- 2 HP 10833A/B/C/D HP-IB cables.
- 1 Test device.

Set-up

Connect the instruments as shown in Figure 1. The following procedure sets the HP-IB addresses of the instruments to operate properly with the programs in this guide. If the HP 82335A HP-IB interface card is not installed in the HP Vectra PC, follow the instructions in the *HP 82335A HP-IB Command Library Manual* for installation. Set the interface select code to 7.

1. Turn on the HP 8350B Sweeper. Press [SHIFT] [LCL]. The FREQUENCY/TIME display shows the current HP-IB address of the source. If it is not 19, press [1] [9] [GHz] to set the address to 19. The HP 8340B or 8341B Synthesized Sweeper operates the same, although the address is displayed in the right-hand display area. For the HP 8360, access the HP-IB menu under the [SYSTEM MENU] key. Verify that the address is 19 and programming language is "Analyzer."

2. Power on the HP 8757D/E Scalar Network Analyzer. The current HP-IB address is shown in the active entry area of the CRT. If it is not 16, press [LOCAL] [8757] [1] [6] [ENT] to set the address to 16.
3. Load Microsoft QuickBASIC by typing "QB/L QBHP-IB" at the MS-DOS prompt.

Check out procedure

Press [PRESET] on the analyzer. If the 8757 SYSTEM INTERFACE is properly connected, and the address of the source correctly set, both the analyzer and the source will perform an instrument preset. If either instrument detects a failure during instrument preset, that instrument displays the error encountered. The operating manual of the source gives instructions to help you interpret the error message. If the analyzer displays an error message, see "In Case of Difficulty."

Programming examples

In the following sections, example programs introduce the HP-IB capabilities of the analyzer. Each example program consists of these sections:

1. A description of the functions exercised.
2. The program listing.
3. An explanation of each program line.
4. Detailed instructions for operating the program.

When you finish all of the example programs, you will have a good idea of the power of the HP 8757D/E when used in an automatic system. Note that line numbers aren't required in Microsoft QuickBASIC but are included in the examples for clarity. Each line number represents a complete statement. No hard line returns are used in the statements although they may appear that way (to improve your ability to read the programs).

In normal programs an error checking line should follow every call to a subprogram:

```
IF PCIB.ERR <>NOERR THEN ERROR  
    PCIB.BASERR
```

This statement may be eliminated if this helps program clarity. During error trapping, if an error occurs, the number corresponding to that error is assigned to the variable PCIB.ERR. PCIB.ERR is compared to NO ERR (=0) and then branches to a HP-IB Command Library subprogram for error handling. A message appears on the computer screen stating the error number and type of error.

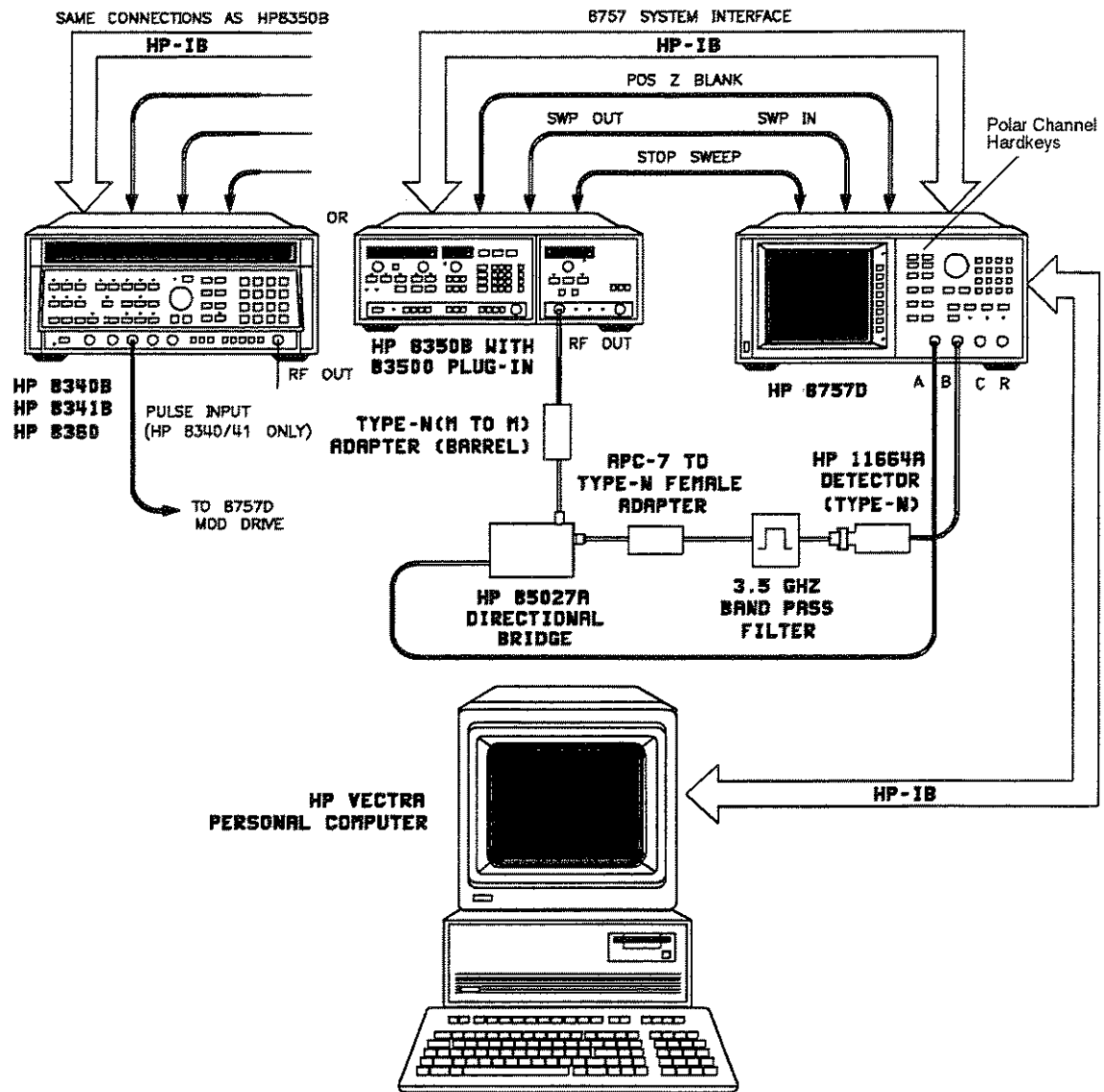

Figure 1. System Connections

Program 1: remote, local, and local lockout

The analyzer may be used with the front panel (local operation) or programmed via HP-IB (remote operation). The programmer of the instrument system has control over the operation of all instruments in the system.

When the computer first addresses an instrument, the instrument is placed in a special remote operating mode, called remote mode. When in remote, the instrument does not respond to its front panel, except for the [LOCAL] key. [LOCAL], when pressed, cancels the remote mode and allows the instrument to be used with its front panel.

The computer can also return the instrument to local operation. To do so, the computer sends a special command that forces the instrument to go to local mode.

Occasionally, the programmer of an automatic system needs to prevent the instrument operator from returning the instrument to local operation (via [LOCAL]). When the local lockout function of the computer is used, the instruments are prevented from exiting remote mode, even when [LOCAL] is pressed.

Frequently, the programmer needs to place the instruments connected to the computer into a known state. When preset, the analyzer defaults to the conditions shown below. The instrument preset function operates the same as the front panel [PRESET] key on the analyzer and the source. When presetting the analyzer and source, send the PRESET command only to the analyzer. The analyzer will preset the source attached to the 8757 SYSTEM INTERFACE.

HP 8757D/E instrument preset conditions

Channels 1 and 2 on. The channel menu appears in the softkey label area of the CRT.

- Measure power A on channel 1.
- Measure power B on channel 2.
- Measure power C² (or B¹) on channel 3.
- Measure power R on channel 4¹.
- Display measurement data in log magnitude format.
- Scale = 20 dB/div.
- Reference level 0 dB for all channels.
- Reference level step size = 20 dB.
- Averaging off.
- Averaging factor = 8.
- Cursor off.
- All labels on.
- Channel 1 as the active channel.
- Modulation drive on.
- Number of points = 401.
- Detector mode set for AC detection.
- Smoothing set for 5.0% of span (off).
- Cursor format = log magnitude.
- Search value = -3 dB¹.
- Adaptive normalization off¹.
- Temperature compensation on.
- Repeat autozero off.
- Detector offset reset to 0 dB.¹
- Detector frequency offset³ off, start and stop = 50 MHz.

Source

- Instrument preset.
- Sweep time set to 200 ms.
- HP 8350B square wave modulation on.
- HP 8340/41 SHIFT PULSE on; RF Output on.
- HP 8360 scalar modulation on; RF output on; ramp sweep mode; analyzer mode.

Plotter

- Abort plot if in progress.
- P1 and P2 scaling points unchanged.
- Selection of plotter pens unchanged.

Printer

- Abort plot if in progress.

Disk drive¹

- Aborts any data transfers in progress.
- Unit number unchanged.

- Volume number unchanged.
- ASCII or binary mode unchanged.

The following analyzer conditions are not changed during a PRESET (IP) command execution:

- Reference position.
- Trace memory.
- Save/Recall registers.
- HP-IB addresses.
- Request mask.
- Limit lines¹.
- Title.
- Detector offset (HP 8757E only).
- User-defined plot.
- 8757 System Interface control on/off.
- Repeat autozero timer.
- Display intensity.
- Display colors¹.

Program 1 listing

```
10 REM $INCLUDE: 'QBSETUP'
20 CLS
30 ISC& = 7
40 Sna& = 716
50 CALL IOTIMEOUT(ISC&, 10!):
   IF PCIB.ERR <>NOERR THEN ERROR PCIB.BASERR
60 CALL IOABORT(ISC&):
   IF PCIB.ERR <>NOERR THEN ERROR PCIB.BASERR
70 CALL IOCLEAR(ISC&):
   IF PCIB.ERR <>NOERR THEN ERROR PCIB.BASERR
80 CALL IOREMOTE(Sna&):
   IF PCIB.ERR <>NOERR THEN ERROR PCIB.BASERR
90 GOSUB PAUSE
100 CALL IOREMOTE(Sna&):
   IF PCIB.ERR <>NOERR THEN ERROR PCIB.BASERR
110 CALL IOLLOCKOUT(ISC&):
   IF PCIB.ERR <>NOERR THEN ERROR PCIB.BASERR
120 GOSUB PAUSE
130 CALL IOLOCAL(Sna&):
   IF PCIB.ERR <>NOERR THEN ERROR PCIB.BASERR
140 GOSUB PAUSE
150 A$ = "IP" CALL IOOUTPUTS(Sna&, A$, LEN(A$)):
   IF PCIB.ERR <>NOERR THEN ERROR PCIB.BASERR
160 END
170 PAUSE: DO UNTIL INKEY$ = CHR$(13): LOOP
180 RETURN
```

Program 1 explanation

Line 10 Call the QuickBASIC initialization file "QBSETUP", which is the setup program for the MS-DOS HP-IB Command Library. This command must appear before the body of the program whenever calls to the HP-IB Command Library are to be made.

Line 20 Clear the computer CRT.

1. HP 8757D only.

2. HP 8757D Option 001 only.

3. HP 8757D with HP 85037 sseries precision detector only.

- Line 30 Assign the interface select code to a variable. This select code is set on the HP 82335A HP-IB interface card.
- Line 40 Assign the address of the HP 8757D/E to a variable.
- Line 50 Define a system timeout of 10 seconds. Timeout allows recovery from I/O operations that aren't completed in less than 10 seconds. Perform error trapping.
- Line 60 Abort any HP-IB transfers. Perform error trapping.
- Line 70 Clear the analyzer's HP-IB interface. Perform error trapping.
- Line 80 Set the analyzer and source to remote mode. Perform error trapping.
- Line 90 Press [ENTER] to continue.
- Line 100 Set the analyzer and source to remote mode. Perform error trapping.
- Line 110 Lock out the [LOCAL] key of the analyzer and source. Perform error trapping.
- Line 120 Press [ENTER] to continue.
- Line 130 Set the analyzer and source to local mode. Perform error trapping.
- Line 140 Press [ENTER] to continue. Perform error trapping.
- Line 150 Preset the analyzer and source. Perform error trapping.
- Line 160 End program execution.
- Line 170 Define a subroutine that waits for the [ENTER] key to be pressed.
- Line 180 Return from the subroutine.

Running program 1

1. Press [ALT] [F] [N] on the computer. This clears the QuickBASIC screen.
2. Type in the program.
3. Press [ALT] [D] [T] to trace the program as it runs. Press [ALT] [R] [S] on the computer to run the program.

4. When the program pauses, the analyzer is in remote mode. You can verify this by observing the lights in the INSTRUMENT STATE area of the analyzer. The R (remote) and L (listen) lights should be on. Try pressing any key on the analyzer (except [LOCAL]). Nothing happens. The source is also in remote mode. Now press [LOCAL] and verify that the keys on the analyzer are active. Also, notice the R light went out when you pressed [LOCAL]. The source went into local mode along with the analyzer.
5. Press [ENTER] on the computer. The analyzer is again in remote mode. This time, however, the [LOCAL] key is locked out. Try pressing [LOCAL] and the other keys. None of the keys on the analyzer or the source cause any action.
6. Press [ENTER] on the computer. All instruments on the HP-IB interface are returned to local mode, including the analyzer and source. Verify that the R light on the analyzer is off and the REM light on the source is off.
7. Press [ENTER] on the computer. The analyzer and source are both preset. Note that the computer sent the instrument PRESET command only to the analyzer. The analyzer, in turn, preset the source.

Remember, to preset both the analyzer and the source, you only need to send the instrument PRESET command to the analyzer. Do not send instrument PRESET to the source by way of passthru mode (discussed in program 3).

Program 2: controlling the front panel

All front panel keys and most of the softkeys of the analyzer may be programmed remotely via HP-IB. For example, you can program the scale per division, reference level, and reference position for each channel.

Program 2 listing

```

10 REM $INCLUDE: 'QBSETUP'
20 CLS
30 ISC& = 7
40 Sna& = 716
50 CALL IOTIMEOUT(ISC&, 10!):
   IF PCIB.ERR <>NOERR THEN ERROR PCIB.BASERR
60 CALL IOABORT(ISC&):
   IF PCIB.ERR <>NOERR THEN ERROR PCIB.BASERR
70 CALL IOCLEAR(ISC&):
   IF PCIB.ERR <>NOERR THEN ERROR PCIB.BASERR
80 A$ = "IP" GOSUB IOOUTS
90 GOSUB PAUSE
100 A$ = "C1C0C2" GOSUB IOOUTS
110 GOSUB PAUSE
120 A$ = "SD10" GOSUB IOOUTS
130 GOSUB PAUSE
140 A$ = "RL-10" GOSUB IOOUTS
150 GOSUB PAUSE
160 A$ = "RP4" GOSUB IOOUTS
170 GOSUB PAUSE
180 A$ = "IA" GOSUB IOOUTS
190 GOSUB PAUSE

```

```

200 A$ = "C0C1 SD5; RP4; RL-5" GOSUB IOOUTS
210 END
220 PAUSE: DO UNTIL INKEY$ = CHR$(13)
230 LOCATE 25, 1: PRINT "Press ENTER to continue"
    LOOP: CLS
240 RETURN
250 IOOUTS: CALL IOOUTPUTS(Sna&, A$, LEN(A$))
260 IF PCIB.ERR <>NOERR THEN ERROR PCIB.BASEERR
270 RETURN

```

Program 2 explanation

Line 10 Call the QuickBASIC initialization file "QBSETUP".

Line 20 Clear the computer CRT.

Line 30 Assign the interface select code to a variable.

Line 40 Assign the HP-IB address of the analyzer to a variable.

Line 50 Define a system timeout of 10 seconds. Perform error trapping.

Line 60 Abort any HP-IB transfers. Perform error trapping.

Line 70 Clear the HP-IB interface of the analyzer. Perform error trapping.

Line 80 Preset the analyzer and source.

Line 90 Press [ENTER] to continue.

Line 100 Select channel 1 and turn it off. Turn on channel 2.

Line 110 Press [ENTER] to continue.

Line 120 Set the scale per division to 10 dB. No terminator (;) is needed because this is the only command in the statement.

Line 130 Press [ENTER] to continue.

Line 140 Set the reference level to -10 dBm. Again, note the absence of a terminator (;).

Line 150 Press [ENTER] to continue.

Line 160 Set the reference position line to the center of the screen (graticule 4). No terminator is needed because this is the only command on the line.

Line 170 Press [ENTER] to continue.

Line 180 Program channel 2 to measure reflection (input A) instead of transmission (input B).

Line 190 Press [ENTER] to continue.

Line 200 There are many commands on one line, with terminators. Turn channel 2 off and channel 1 on (C0C1). Set the scale per division (SD) to 5 dB, reference position line (RP) to the center of the screen, and reference level (RL) to -5 dBm.

Line 210 End execution.

Line 220 Define a subroutine that waits for the [ENTER] key to be pressed before returning to program execution.

Line 230 Locate and print a prompt on the CRT. Clear the screen if the loop is terminated.

Line 240 Return from the subroutine.

Line 250 Define a subroutine that outputs commands to the analyzer.

Line 260 Perform error trapping.

Line 270 Return from the subroutine.

Running program 2

1. Press [ALT] [R] [N] on the computer. This clears the previous program.
2. Type in this program and press [ALT] [R] [S] on the computer.
3. The computer presets the analyzer and source and pauses. Note the settings of channel 1 and 2. Press [ENTER].
4. Channel 1 is turned off. Channel 2 is now the active channel, (notice the highlighted box around the channel 2 mode labels on the analyzer CRT). Press [ENTER].
5. Channel 2 scale per division is now set to 10 dB. It defaulted to 20 dB/div at preset. Press [ENTER].
6. The reference level is set to -10 dBm (it was 0.0 dBm). Press [ENTER].
7. The reference position line is set to the center of the CRT (graticule 4). The top of the CRT is graticule 8 and the bottom is graticule 0. Press [ENTER].
8. Change the measurement to reflection (input A), instead of transmission (input B). At preset, channel 2 defaults to input B. Press [ENTER].
9. In one statement: turn off channel 2, turn on channel 1, set the scale per division to 5 dB, set the reference position line to the center of the CRT, and set the reference level to -5 dBm.

NOTE: The semicolon (;) terminators are needed after any analyzer command that can have a variable length. Extra terminators never hurt, so use them liberally.

Program 3: passthru mode

In normal operation, the system source, digital plotter, printer, and disk drive (HP 8757D only) are connected to the 8757 SYSTEM INTERFACE. This connection allows the analyzer to control and extract information from the other parts of the measurement system. To allow you to control other instruments with the computer, the analyzer has a built-in PASSTHRU command that takes a command from the computer and passes it on to one of the instruments connected to the 8757 SYSTEM INTERFACE.

To initiate passthru mode, tell the analyzer which instrument you wish to command by setting the passthru address. Talk (or listen) to that device, address the analyzer's special passthru HP-IB address (which is different from the analyzer's HP-IB address). While in the passthru mode, the analyzer stops updating its CRT and does not respond to its front panel (because it's in remote mode). To remove the analyzer from passthru mode, address it via HP-IB. While in passthru mode, do not press [LOCAL] on the analyzer.

The analyzer's passthru address is calculated from its HP-IB address. If the address of the analyzer is even (such as 16 decimal) then the passthru address is the next larger number (17 decimal). If the address of the analyzer is odd (such as 15 decimal), then the passthru address is the next smaller number (14 decimal). Never set the address of the analyzer so that its address conflicts with one of the instruments connected to the 8757 SYSTEM INTERFACE. For instance, if the source is set to 19 decimal, do not set the analyzer address to 19.

Data can be sent to or received from any instrument on the 8757 SYSTEM INTERFACE via passthru mode. The IOLOCAL, IOREMOTE, and IOTRIGGER HP-IB messages do not pass through the analyzer.

Program 3 listing

```
10 REM $INCLUDE: 'QBSETUP'
20 CLS
30 ISC& = 7
40 Sna& = 716
50 Passthru& = 717
60 CALL IOTIMEOUT(ISC&, 10!):
  IF PCIB.ERR <>NOERR THEN ERROR PCIB.BASERR
70 CALL IOABORT(ISC&):
  IF PCIB.ERR <>NOERR THEN ERROR PCIB.BASERR
80 CALL IOCLEAR(ISC&):
  IF PCIB.ERR <>NOERR THEN ERROR PCIB.BASERR
90 A$ = "IP" GOSUB IOOUTS
100 A$ = "PT19" GOSUB IOOUTS
110 A$ = "OFFA" GOSUB IOOUTSP
120 CALL IOENTER(Passthru&, Min.freq):
  IF PCIB.ERR <>NOERR THEN ERROR PCIB.BASERR
130 Min.freq = Min.freq / 1E+09
140 A$ = "OFFB" GOSUB IOOUTSP
150 CALL IOENTER(Passthru&, Max.freq):
  IF PCIB.ERR <>NOERR THEN ERROR PCIB.BASERR
160 Max.freq = Max.freq / 1E+09
170 A$ = "" GOSUB IOOUTS
```

```
180 PRINT "Frequency limits: "; Min.freq; "to";
  Max.freq; "GHz"
190 INPUT "Start frequency (GHz)?", Start.freq
200 INPUT "Stop frequency (GHz)?", Stop.freq
210 A$ = "FA" +STR$(Start.freq) + "GZ FB"
  +STR$(Stop.freq) + "GZ" GOSUB IOOUTSP
220 A$ = "" GOSUB IOOUTS
230 END
240 IOOUTS: CALL IOOUTPUTS(Sna&,A$,LEN(A$))
250 IF PCIB.ERR <>NOERR THEN ERROR PCIB.BASERR
260 RETURN
270 IOOUTSP: CALL IOOUTPUTS(Passthru&, A$, LEN(A$))
280 IF PCIB.ERR <>NOERR THEN ERROR PCIB.BASERR
290 RETURN
```

Program 3 explanation

- Line 10 Call the QuickBASIC initialization file "QBSETUP".
- Line 20 Clear the computer CRT.
- Line 30 Assign the interface select code to a variable.
- Line 40 Assign the address of the analyzer to a variable. (This is the analyzer's control address).
- Line 50 Assign the analyzer's passthru address to a variable. By communicating to this HP-IB address, the computer will control a device connected to the 8757 SYSTEM INTERFACE.
- Line 60 Define a system timeout of 10 seconds. Perform error trapping.
- Line 70 Abort any HP-IB transfers. Perform error trapping.
- Line 80 Clear the HP-IB interface of the analyzer. Perform error trapping.
- Line 90 Preset the analyzer and source.
- Line 100 Tell the analyzer which device is controlled through the analyzer's passthru address. In this case, the source (device 19).
- Line 110 Send a command to the source. Command it to output its current start frequency.
- Line 120 Read the start frequency from the source. Perform error trapping.
- Line 130 Scale the start frequency to display it in GHz.
- Line 140 Command the source to output its current stop frequency.
- Line 150 Read the stop frequency from the source. Perform error trapping.
- Line 160 Scale the stop frequency to display it in GHz.
- Line 170 Exit passthru mode by addressing the analyzer.
- Line 180 Print the start and stop frequencies.
- Line 190 Get start frequency from user.
- Line 200 Get stop frequency from user.

- Line 210 Set start and stop frequencies of source to those given by the user.
- Line 220 Exit passthru mode by addressing the analyzer.
- Line 230 End program execution.
- Line 240 Define a subroutine that outputs commands to the analyzer.
- Line 250 Perform error trapping.
- Line 260 Return from the subroutine.
- Line 270 Define a subroutine that outputs commands to the source through the passthru address of the analyzer.
- Line 280 Perform error trapping.
- Line 290 Return from the subroutine.

Running program 3

1. Clear the computer CRT and type in the program.
2. Press [ALT] [R] [S] on the computer to run the program.
3. The computer presets the analyzer and the source, reads the start and stop frequency of the source, and displays it on the CRT of the computer. At preset, the source defaults to the full frequency range of the plug-in. The values read represent the frequency limits of this plug-in. When the computer stops, it displays the prompt:

Start frequency (GHz)?

Enter a start frequency in the frequency range of the plug-in and press [ENTER].

4. The computer displays the prompt:

Stop frequency (GHz)?

Enter a stop frequency in the frequency range of the plug-in (but higher than the start frequency) and press [ENTER].

5. The computer sets the start and stop frequency of the source to those you entered. The analyzer immediately begins sweeping the frequency range you defined.

NOTE: You must address the analyzer after using passthru mode to return it to normal swept operation. Any command can be sent via passthru mode to any instrument on the 8757 SYSTEM INTERFACE, and any data can be read. Service requests and parallel polls do not pass through the analyzer.

Program 4: cursor operations

To enhance the speed and accuracy of measurements, the analyzer contains a built-in cursor that displays the frequency and magnitude of a trace at any given point. To make measurements even more efficient, the cursor may be set to the maximum or minimum point on the trace simply by pressing a softkey. These cursor functions are available via HP-IB commands.

With a computer, the cursor may be turned on and off, its position (0 to n-1, where n is the number of points per trace) set, its value and position read, and set to the maximum or minimum point on the trace. The cursor functions all apply to the active channel (the channel accessed most recently). You have complete control over cursor operations via HP-IB.

Cursor programming is especially useful for measuring parameters like flatness and maximum power, where you are interested in the highest and lowest point on the trace. For measuring parameters such as 3 dB points and other specific points (not a maximum or minimum), it is more efficient to use either the cursor search functions (available on the HP 8757D only) or to read the entire trace and search for the points you need.

Program 4 listing

```

10  REM $INCLUDE: 'QBSETUP'
20  CLS
30  Start.freq = 2
40  Stop.freq = 5
50  ISC& = 7
60  Sna& = 716
70  Passthru& = 717
80  CALL IOTIMEOUT(ISC&, 10!):
   IF PCIB.ERR <>NOERR THEN ERROR PCIB.BASERR
90  CALL IOABORT(ISC&):
   IF PCIB.ERR <>NOERR THEN ERROR PCIB.BASERR
100 CALL IOCLEAR(ISC&):
   IF PCIB.ERR <>NOERR THEN ERROR PCIB.BASERR
110 A$ = "IP" GOSUB IOOUTS
120 A$ = "PT19" GOSUB IOOUTS
130 A$ = "FA" +STR$(Start.freq) + "GZ FB"
   +STR$(Stop.freq) + "GZ" GOSUB IOOUTSP
135 A$=""GOSUB IOOUTS
140 A$ = "C2 CXOC" GOSUB IOOUTS
150 Max% = 2
160 Actual% = 0
170 DIM Cursor.vals(Max%)
180 CALL IOENTERA(Sna&, SEG Cursor.vals(0), Max%,
   Actual%):
   IF PCIB.ERR <>NOERR THEN ERROR PCIB.BASERR
190 PRINT "Cursor reads"; Cursor.vals(0); "dB at
   position"; Cursor.vals(1)
200 INPUT "Desired cursor position (0..400)?",
   New.posn
210 A$ = "SC" +STR$(INT(New.posn +.5)): GOSUB
   IOOUTS
220 A$ = "OC" GOSUB IOOUTS
230 CALL IOENTERA(Sna&, SEG Cursor.vals(0), Max%,
   Actual%):
   IF PCIB.ERR <>NOERR THEN ERROR PCIB.BASERR
240 PRINT "Value at position"; Cursor.vals(1); " is
   "; Cursor.vals(0); "dB."

```

```

250 INPUT "Cursor frequency (GHz)?", Cur.freq
260 New.posn = 400 * ((Cur.freq -Start.freq) /
  (Stop.freq -Start.freq))
270 A$ = "SC" +STR$(INT(New.posn +.5)): GOSUB
  IOOUTS
280 A$ = "OC" GOSUB IOOUTS
290 CALL IOENTERA(Sna&, SEG Cursor.vals(0), Max%,
  Actual%):
  IF PCIB.ERR <>NOERR THEN ERROR PCIB.BASERR
300 Cur.freq = Start.freq +(Stop.freq -Start.freq)
  * (Cursor.vals(1) / 400)
310 PRINT "Cursor reads"; Cursor.vals(0); "dB at";
  Cur.freq; "GHz."
320 END
330 IOOUTS: CALL IOOUTPUTS(Sna&, A$ LEN(A$))
340 IF PCIB.ERR <>NOERR THEN ERROR PCIB.BASERR
350 RETURN
360 IOOUTSP: CALL IOOUTPUTS(Passthru&, A$, LEN(A$))
370 IF PCIB.ERR <>NOERR THEN ERROR PCIB.BASERR
380 RETURN

```

Program 4 explanation

Line 10 Call the QuickBASIC initialization file "QBSETUP".

Line 20 Clear the computer CRT.

Line 30 Define the start frequency of the desired sweep in GHz.

Line 40 Define the stop frequency of the desired sweep in GHz.

Line 50 Assign the interface select code to a variable.

Line 60 Assign the address of the analyzer to a variable.

Line 70 Assign the passthru address of the analyzer to a variable.

Line 80 Define a timeout of 10 seconds. Perform error trapping.

Line 90 Abort any HP-IB transfers. Perform error trapping.

Line 100 Clear the HP-IB interface of the analyzer. Perform error trapping.

Line 110 Preset the analyzer and source. This sets the number of points per trace to 401.

Line 120 Tell the analyzer which instrument is controlled through the passthru address (19 is the source).

Line 130 Command the source to set a start frequency of 2 GHz and a stop frequency of 5 GHz.

Line 135 Turn passthru mode off. Allow analyzer to update.

Line 140 Set the cursor to the maximum point on channel 2 and command the analyzer to output the cursor's value and position.

Line 150 Define the maximum number of elements to be read into an array.

Line 160 Define the actual number of elements read.

Line 170 Dimension an array to contain the cursor value and position.

Line 180 Read the value and position of the cursor. Perform error trapping.

Line 190 Print the value and position of the cursor on the computer CRT.

Line 200 Get new cursor position from the user. Input should be between 0 and 400.

Line 210 Set the cursor to the new cursor position chosen by the user.

Line 220 Command the analyzer to output the cursor's value and position.

Line 230 Read the value and position of the cursor at its new position. Perform error trapping.

Line 240 Print the cursor's value and position on the computer CRT.

Line 250 Get new cursor frequency from the user. It must be within the frequency range of the sweep selected.

Line 260 Calculate the position of the cursor from its frequency and the start and stop frequencies of the current measurement.

Line 270 Set the cursor to the desired position.

Line 280 Command the analyzer to output the cursor's value and position.

Line 290 Read the cursor's value and position. Perform error trapping.

Line 300 Calculate the cursor's actual frequency from its position and the start and stop frequencies of the current measurement. You can easily program other start and stop frequencies by following the example in program 3.

Line 310 On the computer CRT, print the value and actual frequency of the cursor.

Line 320 End program execution.

Line 330 Define a subroutine that outputs commands to the analyzer.

Line 340 Perform error trapping.

Line 350 Return from the subroutine.

Line 360 Define a subroutine that outputs commands to the source through the passthru address of the analyzer.

Line 370 Perform error trapping.

Line 380 Return from the subroutine.

Running program 4

1. Clear the computer CRT and type in the program.
2. Press [ALT] [R] [S] on the computer.
3. The computer turns on both channels and sets channel 1 to reflection (input A) and channel 2 to transmission (input B). The cursor is positioned to the maximum point on the channel 2 trace and its value and position are read and displayed. At preset, the number of points per trace is 401.
4. The computer displays the prompt:

Desired cursor position (0..400)?

Type in a number between 0 and 400 and press [ENTER]. A position of 0 represents the left side of the analyzer's CRT (lowest frequency) and 400 represents the right side of the CRT (highest frequency). The position is set, and the cursor's value and position is read and printed on the CRT of the computer.

5. The computer stops and displays the prompt:

Cursor frequency (GHz)?

Enter a frequency within the current start and stop frequencies of the measurement (0.01 to 20 GHz). The nearest cursor position is calculated and set. The value and position of the cursor are read, and the actual cursor frequency is calculated from the cursor's position.

NOTE: The original desired frequency and the actual cursor frequency are usually different. Because there are only 401 possible cursor positions, some frequencies cannot be set exactly.

To use more points per trace when using the HP 8757D, modify line 110 to be "IP SP801" for 801 points. Then modify the "400" in lines 200, 260, and 300, to "800".

Program 5: read a single value

Measurements often require that a single value be read at a CW frequency, particularly when extremely good frequency accuracy and resolution are required.

The analyzer is able to read and send a single reading of any measurement channel, via HP-IB, to the computer. The OUTPUT VALUE (OV) command operates on the active channel and causes the analyzer to send one reading of measurement data. Even when the analyzer is in normalized mode (MEAS-MEM), the OV command sends the measured, not the normalized, data.

Program 5 listing

```
10 REM $INCLUDE: 'QBSETUP'  
20 CLS  
30 ISC& = 7  
40 Sna& = 716  
50 Passthru& = 717
```

```
60 CALL IOTIMEOUT(ISC&, 10!):  
IF PCIB.ERR <>NOERR THEN ERROR PCIB.BASERR  
70 CALL IOABORT(ISC&):  
IF PCIB.ERR <>NOERR THEN ERROR PCIB.BASERR  
80 CALL IOCLEAR(ISC&):  
IF PCIB.ERR <>NOERR THEN ERROR PCIB.BASERR  
90 A$ = "IP" GOSUB IOOUTS  
100 A$ = "PT19" GOSUB IOOUTS  
110 A$ = "SW0" GOSUB IOOUTS  
120 Freq = 2  
130 Freq.step = .1  
140 A$ = "CW" +STR$(Freq) + "GZ SF"  
+STR$(Freq.step) + "GZ" GOSUB IOOUTSP  
150 A$ = "CI1A" GOSUB IOOUTS  
160 FOR I = 1 TO 21  
170 A$ = "OV" GOSUB IOOUTS  
180 CALL IOENTER(Sna&, Value):  
IF PCIB.ERR <>NOERR THEN ERROR PCIB.BASERR  
190 PRINT I; ":", Value; "dB at"; Freq; "GHz"  
200 A$ = "CW UP" GOSUB IOOUTSP  
210 Freq = Freq +Freq.step  
220 NEXT I  
230 A$ = "FA2GZ FB4GZ" GOSUB IOOUTSP  
240 A$ = "SW1" GOSUB IOOUTS  
250 END  
260 IOOUTS: CALL IOOUTPUTS(Sna&, A$, LEN(A$))  
270 IF PCIB.ERR <>NOERR THEN ERROR PCIB.BASERR  
280 RETURN  
290 IOOUTSP: CALL IOOUTPUTS(Passthru&, A$, LEN(A$))  
300 IF PCIB.ERR <>NOERR THEN ERROR PCIB.BASERR  
310 RETURN
```

Program 5 explanation

- Line 10 Call the QuickBASIC initialization file "QBSETUP".
- Line 20 Clear the computer CRT.
- Line 30 Assign the interface select code to a variable.
- Line 40 Assign the address of the analyzer to a variable.
- Line 50 Assign the passthru address of the analyzer to a variable.
- Line 60 Define a system timeout of 10 seconds. Perform error trapping.
- Line 70 Abort any HP-IB transfers. Perform error trapping.
- Line 80 Clear the HP-IB interface of the analyzer. Perform error trapping.
- Line 90 Preset the analyzer and source.
- Line 100 Tell the analyzer which instrument is controlled through the passthru address (19 is the source).
- Line 110 Put the analyzer in non-swept mode. This step is necessary to read single values. After receiving this command, the analyzer stops updating its display.
- Line 120 Define a start frequency for further measurements (in GHz).
- Line 130 Define a frequency increment (in GHz).

Line 140 Put the source into CW mode at the start frequency and set its frequency step size to that of the frequency increment.

Line 150 Command the analyzer to measure reflection (input A) on channel 1. This statement also causes the analyzer to exit passthru mode.

Line 160 Make 21 measurements, at equally-spaced CW frequencies.

Line 170 Command the analyzer to send the current reading of channel 1 (the active channel) to the computer. The reading is taken immediately.

Line 180 Read the value. In this instance, no format has been defined so the default format of ASCII is in effect.

Line 190 Print the measurement number, the reading, and the frequency on the computer CRT.

Line 200 Command the source to increment the CW frequency by the step size set earlier (line 110). This is a very fast way of setting a series of equally-spaced frequencies.

Line 210 Increment the variable that contains the current frequency. This variable is only used for printing the current frequency at each iteration of the loop.

Line 220 End of the loop.

Line 230 Command the source to sweep from 2 to 4 GHz. The source exits CW mode and returns to start/stop mode.

Line 240 Command the analyzer to return to swept mode. The analyzer again updates the trace information on the display. This command also exits passthru mode.

Line 250 End program execution.

Line 260 Define a subroutine that outputs commands to the analyzer.

Line 270 Perform error trapping.

Line 280 Return from the subroutine.

Line 290 Define a subroutine that outputs commands to the source through the passthru address of the analyzer.

Line 300 Perform error trapping.

Line 310 Return from the subroutine.

Running program 5

1. Clear the computer CRT and type in the program.
2. Press [ALT] [R] [S] on the computer.

3. The source frequency is set immediately to 2 GHz and the computer begins reading reflection (input A) of the analyzer and printing the measurements. After 21 readings, the program ends.

Program 6: trace transfer

One feature that sets the HP 8757D/E apart is its ability to transfer an entire measurement trace to a computer at very high speed. A complete, high-resolution (0.01 dB) 401-point measurement can be sent to the computer in 35 milliseconds (binary format) or 800 milliseconds (ASCII format). Transfer time will be less for fewer points per trace, and greater for more points per trace.

The analyzer gives you complete flexibility when reading measurement traces via HP-IB. You can read from the active channel and you can read the stored memory trace, the current measurement trace, or the normalized trace (measurement-minus-memory). In addition, the memory trace can be written back to the analyzer, allowing you to save and restore calibration traces via HP-IB.

With trace transfer measurements, some frequency resolution is sacrificed for measurement speed. The number of points per trace can be programmed to control the resolution across the frequency range being swept. If you are measuring a device that changes very rapidly with frequency, it is possible to miss very narrowband responses that occur between measurement points if the resolution is low. For these cases, the measurement should be made at a higher resolution. The trace transfer method of measurement is much faster than CW point-by-point measurements.

Program 6 listing

```

10  REM $INCLUDE: 'QBSETUP'
20  CLS
30  ISC& = 7
40  Sna& = 716
50  DIM Ascii.dat(1 TO 401),Binary.dat%(1 TO 401)
60  Max1% = 401
70  Max2% = 2 * Max1%
80  CALL IOTIMEOUT(ISC&, 10!):
   IF PCIB.ERR <> NOERR THEN ERROR PCIB.BASERR
90  CALL IOABORT(ISC&):
   IF PCIB.ERR <> NOERR THEN ERROR PCIB.BASERR
100 CALL IOCLEAR(ISC&):
   IF PCIB.ERR <> NOERR THEN ERROR PCIB.BASERR
110 A$ = "IP" GOSUB IOOUTS
120 A$ = "C1IA;C2IB" GOSUB IOOUTS
130 Start = TIMER
140 Stopped = TIMER
150 DO UNTIL ((Stopped - Start) >2)
160 Stopped = TIMER
170 LOOP
180 A$ = "FD2;C1OD" GOSUB IOOUTS
190 Actual% = 0
200 CALL IOENTERA(Sna&, SEG Ascii.dat(1), Max1%,
   Actual%):IF PCIB.ERR <> NOERR THEN ERROR
   PCIB.BASERR
210 CALL IOEOL(ISC&, CHR$(13) + CHR$(10), 0): IF
   PCIB.ERR <> NOERR THEN ERROR PCIB.BASERR
220 A$ = "C1WM" GOSUB IOOUTS

```

```

230 CALL IOEOL(ISC&, CHR$(13) + CHR$(10), 2): IF
PCIB.ERR <> NOERR THEN ERROR PCIB.BASERR
240 CALL IOOUTPUTA(Sna&, SEG Ascii.dat(1), Max1%):
IF PCIB.ERR <> NOERR THEN ERROR PCIB.BASERR
250 A$ = "C1MY" GOSUB IOOUTS
260 DO UNTIL INKEY$ = CHR$(13): LOCATE 25, 1
270 PRINT "Press ENTER to continue" LOOP: CLS
280 A$ = "C1C0;C2MY" GOSUB IOOUTS
290 Actual% = 0
300 A$ = "FD3;C2OD" GOSUB IOOUTS
310 CALL IOENTERB(Sna&, SEG Binary.dat%(1), Max2%,
Actual%, 1):
IF PCIB.ERR <> NOERR THEN ERROR PCIB.BASERR
320 CALL IOEOL(ISC&, CHR$(13) + CHR$(10), 0):
IF PCIB.ERR <> NOERR THEN ERROR PCIB.BASERR
330 A$ = "C2WM" GOSUB IOOUTS
340 CALL IOEOL(ISC&, CHR$(13) + CHR$(10), 2): IF
PCIB.ERR <> NOERR THEN ERROR PCIB.BASERR
350 CALL IOOUTPUTB(Sna&, SEG Binary.dat%(1), Max2%,
1):
IF PCIB.ERR <> NOERR THEN ERROR PCIB.BASERR
360 DO UNTIL INKEY$ = CHR$(13): LOCATE 25, 1
370 PRINT "Press ENTER to continue" LOOP: CLS
380 FOR I% = 1 TO Max1%
390 Binary.dat%(I%) = (I% MOD 100)
400 NEXT I%
410 A$ = "C2C0;C1MY" GOSUB IOOUTS
420 CALL IOEOL(ISC&, CHR$(13) + CHR$(10), 0):
IF PCIB.ERR <> NOERR THEN ERROR PCIB.BASERR
430 A$ = "FD3;C1WM" GOSUB IOOUTS
440 CALL IOOUTPUTB(Sna&, SEG Binary.dat%(1), Max2%,
1): IF PCIB.ERR <> NOERR THEN ERROR PCIB.BASERR
450 CALL IOEOL(ISC&, CHR$(13) + CHR$(10), 2):
IF PCIB.ERR <> NOERR THEN ERROR PCIB.BASERR
460 A$ = "AS" GOSUB IOOUTS
470 END
480 IOOUTS: CALL IOOUTPUTS(Sna&, A$, LEN(A$))
490 IF PCIB.ERR <> NOERR THEN ERROR PCIB.BASERR
500 RETURN

```

Program 6 explanation

Line 10 Call the QuickBASIC initialization file "QBSETUP".

Line 20 Clear the computer CRT.

Line 30 Assign the interface select code to a variable.

Line 40 Assign the address of the analyzer to a variable.

Line 50 Dimension an array to hold a trace of 401 points in ASCII format. Dimension a second array to hold another 401 points trace in binary format.

Line 60 Create a variable based on the number of points per sweep on the analyzer. By using a variable here it helps to make the program easily adaptable to different numbers of trace points.

Line 70 Create a variable to define the number of bytes used in the binary trace transfer.

Line 80 Define a system timeout of 10 seconds. Perform error trapping.

Line 90 Abort any HP-IB transfers. Perform error trapping.

Line 100 Clear the HP-IB interface of the analyzer. Perform error trapping.

Line 110 Preset the analyzer and the source. This sets the number of points per trace to 401.

Line 120 Set channel 1 to reflection (input A) and channel 2 to transmission (input B).

Line 130 Set a start time using the TIMER function in QuickBASIC.

Line 140 Set an initial stop time to be compared to the start time.

Line 150 Loop until 2 seconds have elapsed from the start time.

Line 160 Update the time.

Line 170 End of the 2 second loop.

Line 180 Set the data format to Extended ASCII and command the analyzer to output the channel 1 measurement data.

Line 190 Initialize the variable specifying the number of elements actually read into the array.

Line 200 Read the measurement trace data from channel 1. Perform error trapping.

Line 210 Disable the end-of-line string (carriage return/linefeed) that is sent after any IOOUTPUT command.

Line 220 Command the analyzer to input data into the trace memory of channel 1.

Line 230 Enable the end-of-line string (carriage return/linefeed) that is sent after any IOOUTPUT command.

Line 240 Write the measured trace data back to the trace memory of channel 1. Reading the measurement trace and storing it back into trace memory is equivalent to executing the MEAS-MEM function (HP-IB command SM). Perform error trapping.

Line 250 Command channel 1 to display the trace memory data.

Line 260 Press [ENTER] to continue.

Line 270 Print a message on the computer's CRT notifying the user that the computer is waiting for a key to be pressed before continuing.

Line 280 Turn channel 1 off and channel 2 on. Command the analyzer to display the trace memory from channel 2.

Line 290 Initialize the variable specifying the number of elements actually read into the array.

Line 300 Set the data format to PC binary format. Command the analyzer to output its channel 2 measurement trace data.

Line 310 Read the binary measurement data from channel 2. Perform error trapping.

Line 320 Disable the end-of-line string (carriage return/linefeed) that is sent after any IOOUTPUT command.

Line 330 Command the analyzer to input data into the trace memory of channel 2.

Line 340 Enable the end-of-line string (carriage return/linefeed) that is sent after any IOOUTPUT command.

Line 350 Write the binary data array back to the trace memory of channel 2. Perform error trapping.

Line 360 Press [ENTER] to continue.

Line 370 Print a message on the computer's CRT notifying the user that the computer is waiting for a key to be pressed before continuing. Line 380 Set up a loop to create 401 measurement points.

Line 390 Calculate some arbitrary function and fill the binary data array. This function has no particular meaning, but represents some special calibration data (such as an open/short average).

Line 400 End of the loop.

Line 410 Turn channel 2 off and display the channel 1 trace memory.

Line 420 Disable the end-of-line string (carriage return/linefeed) that is sent after any IOOUTPUT command.

Line 430 Command the analyzer to input data into the trace memory of channel 2.

Line 440 Write the binary data array to the trace memory of channel 2. Perform error trapping.

Line 450 Enable the end-of-line string (carriage return/linefeed) that is sent after any IOOUTPUT command.

Line 460 Autoscale the display on channel 1.

Line 470 End program execution.

Line 480 Define a subroutine that outputs commands to the analyzer.

Line 490 Perform error trapping.

Line 500 Return from the subroutine.

Running program 6

1. Clear the computer CRT and type in the program.
2. Press [ALT] [R] [S] on the computer.
3. Watching the analyzer CRT, you will see DATA DUMP TO HP-IB when it begins sending trace data to the computer, and DATA DUMP TO TRACE MEMORY when the computer sends data back.
4. Watching the analyzer CRT, press [ENTER] on the computer. The computer again reads and writes a trace of data. The analyzer displays the same messages. This time the transfer occurs much more rapidly. A binary transfer takes about 35 milliseconds to be completed while an ASCII trace transfer requires about 800 milliseconds each way.
5. Press [ENTER] on the computer. The computer calculates an arbitrary function and sends it to trace memory of the analyzer, where it is autoscaled and displayed. This function has no significance. It represents a special calibration trace, such as a short/open average. With a computer, the analyzer measurement system can be calibrated over several different frequency ranges and changed from one to another very quickly, with-out recalibration.

If you wish to transfer a higher resolution trace with the HP 8757D, modify line 110 to be "IP SP801" for 801 points. Then modify "401" in lines 50 and 60 to "801."

Program 7: using the TAKE SWEEP command

To make measurements as quickly and efficiently as possible, it is often necessary to synchronize the source with the analyzer. The TAKE SWEEP command gives the analyzer the ability to command the source to make a specified number of complete sweeps (1 to 255). This command is especially useful when using the trace transfer method of reading data from the analyzer.

To use the TAKE SWEEP command, place the analyzer in non-swept mode (SW0). Then give the TAKE SWEEP command with the number of sweeps desired (TSd). At the end of the specified number of sweeps, the analyzer informs the computer of the completion of this operation by setting a bit in its status byte.

The computer can detect this event in two ways:

- Monitor the status byte continuously until the bit is set (polling).
- Let the analyzer generate a service request (SRQ) and interrupt the computer.

Table 1 is a diagram of the status bytes of the analyzer. It shows all of the bits that can be used to either monitor or interrupt the computer. In this program, bit 4 (decimal value 16) is used to signal "operation complete" (all of the sweeps specified by the TAKE SWEEP command have been completed.)

When you follow the take sweep command with an output statement, such as OUTPUT DATA (OD), the data is sent immediately, not after the instructed number of sweeps. The two approaches mentioned overcome this by letting us send the data at the end of the specified number of sweeps, not immediately. A third approach is to use the sweep hold mode (SW2) instead of the non-swept mode (SW0). In this mode the analyzer will prevent any HP-IB operations until the completion of the TAKE SWEEP command.

Program 7 listing

```

10  REM $INCLUDE: 'QBSETUP'
20  CLS
30  DIM ASCIIDAT(0 TO 400)
40  Isc& = 7
50  Sna& = 716
60  Passthru& = 717
70  CALL IOTIMEOUT(Isc&, 10):
    IF PCIB.ERR <> NOERR THEN ERROR PCIB.BASERR
80  CALL IOABORT(Isc&):IF PCIB.ERR <> NOERR THEN
    ERROR PCIB.BASERR
90  CALL IOCLEAR(Isc&):
    IF PCIB.ERR <> NOERR THEN ERROR PCIB.BASERR
100 A$ = "IP" GOSUB IOOUTS
110 A$ = "PT19" GOSUB IOOUTS
120 A$ = "ST250MS" CALL IOOUTPUTS(Passthru&, A$,
    LEN(A$)):
    IF PCIB.ERR <> NOERR THEN ERROR PCIB.BASERR
130 A$ = "C2C0 IB" GOSUB IOOUTS
140 A$ = "SW0;CS;RM16;" GOSUB IOOUTS
150 Stat% = 0
160 A$ = "TS10;" GOSUB IOOUTS
170 DO UNTIL ((Stat% MOD 32) > 15)
180 CALL IOSPOLL(Sna&, Stat%):
    IF PCIB.ERR <> NOERR THEN ERROR PCIB.BASERR
190 LOOP
200 A$ = "C10D" GOSUB IOOUTS
210 Max% = 401
220 Actual% = 0
230 CALL IOENTERA(Sna&, SEG ASCIIDAT(0), Max%,
    Actual%):
    IF PCIB.ERR <> NOERR THEN ERROR PCIB.BASERR
240 A$ = "SW1" GOSUB IOOUTS
250 DO UNTIL INKEY$ = CHR$(13): LOCATE 25, 1
260 PRINT "Press ENTER to continue" LOOP: CLS
270 PEN OFF
280 A$ = "SW0;CS;RM16;" GOSUB IOOUTS
290 CALL IOPEN(Isc&, 0)
300 ON PEN GOSUB Srq.recv
310 PEN ON
320 A$ = "TS10;" GOSUB IOOUTS
330 Wait.srq: '
340 IF Intr.bit% = 0 THEN GOTO Wait.srq
350 PEN OFF
360 END
370 Srq.recv: '
380 CALL IOSPOLL(Sna&, Intr.bit%):
    IF PCIB.ERR <> NOERR THEN ERROR PCIB.BASERR
390 A$ = "RM0" GOSUB IOOUTS
400 A$ = "C10D" GOSUB IOOUTS
410 Max% = 401
420 Actual% = 0
430 CALL IOENTERA(Sna&, SEG ASCIIDAT(0), Max%,
    Actual%):
    IF PCIB.ERR <> NOERR THEN ERROR PCIB.BASERR

```

```

440 A$ = "SW1" GOSUB IOOUTS
450 RETURN
460 IOOUTS: CALL IOOUTPUTS(Sna&, A$, LEN(A$))
470 IF PCIB.ERR <> NOERR THEN ERROR PCIB.BASERR
480 RETURN

```

Program 7 explanation

Line 10 Call the QuickBASIC initialization file "QBSETUP".

Line 20 Clear the computer CRT.

Line 30 Dimension an array large enough to hold a trace of data (401 points).

Line 40 Assign the interface select code to a variable.

Line 50 Assign the address of the analyzer to a variable.

Line 60 Assign the passthru address of the analyzer to a variable.

Line 70 Define a system timeout of 10 seconds. Perform error trapping.

Line 80 Abort any HP-IB transfers. Perform error trapping.

Line 90 Clear the HP-IB interface of the analyzer. Perform error trapping.

Line 100 Preset the analyzer and source.

Line 110 Tell the analyzer which device is controlled through the passthru address. Address 19 belongs to the source.

Line 120 Set the source to 250 milliseconds per sweep. Perform error trapping.

Line 130 Turn off channel 2 of the analyzer and select transmission (input B) for display on channel 1.

Line 140 Put the analyzer into non-swept mode. Clear the status register of the analyzer. Set the request mask to 16 (bit 4) so that the analyzer will set bit 4 (operation complete) at the completion of the TAKE SWEEP command. Table 1 has a description of all bits in the status bytes.

Line 150 Assign the status variable initially to zero.

Line 160 Command the analyzer to take 10 sweeps.

Line 170 Wait for the 10 sweeps to completed by testing the status byte to see if bit 4 is set. Remain in the loop until bit 4 is set.

Line 180 Read the analyzer status byte. Perform error trapping.

Line 190 End of the loop.

Line 200 Command the analyzer to output the channel 1 trace data.

Line 210 Define the maximum number of elements to be read into an array.

Line 220 Define the actual number of elements read.

Line 230 Read the trace data. Perform error trapping.

Line 240 Return the analyzer to swept mode. The display now updates continuously.

Line 250 Wait for the [ENTER] key to be pressed. Locate where the prompt will be displayed on the CRT.

Line 260 Print a prompt on the CRT. Clear the screen if the loop was terminated.

Line 270 HP-IB service requests are implemented as lightpen events. This statement disables any lightpen event trapping.

Line 280 Put the analyzer into non-swept mode. Clear the status register of the analyzer. Set the request mask to 16 (bit 4) so that the analyzer will set bit 4 (operation complete) at the completion of the TAKE SWEEP command. This is the same as in line 140 except that we will look for interrupts this time.

Line 290 Enable the HP-IB interface to detect HP-IB service requests and process the interrupt as ON PEN events.

Line 300 Line label for routine that is executed when an interrupt is detected.

Line 310 Enable HP-IB service request interrupt event trapping.

Line 320 Command the analyzer to take 10 sweeps.

Line 330 Line label for loop that waits for an interrupt.

Line 340 If a service request was not detected, continue looping.

Line 350 Disable HP-IB service request interrupt event trapping.

Line 360 End program execution.

Line 370 Line label for routine that services the interrupts.

Line 380 Serial poll the analyzer. Reading the status byte of the analyzer clears the SRQ. The CLEAR STATUS (CS) command could also be used. Perform error trapping.

Line 390 Disable interrupt generation from the analyzer.

Line 400 Command the analyzer to output the channel 1 trace data.

Line 410 Define the maximum number of elements to be read into an array.

Line 420 Define the actual number of elements read.

Line 430 Read the trace data. Perform error trapping.

Line 440 Return the analyzer to swept mode. The display now updates continuously.

Line 450 Return from subroutine.

Line 460 Define a subroutine that outputs commands to the analyzer.

Line 470 Perform error trapping.

Line 480 Return from the subroutine.

Running program 7

1. Clear the computer CRT and type in the program.
2. Press [ALT] [R] [S] on the computer.
3. The computer first presets the analyzer and source. It then sets the source to 250 milliseconds per sweep, and sets the analyzer to display transmission on channel 1.
4. The computer commands the analyzer to take 10 sweeps and polls the analyzer status byte to determine when they were completed. The computer reads a trace from the analyzer. Just before the trace is sent, you should see the display "freeze" as the TAKE SWEEP command is completed.
5. Press [ENTER], and the computer again tells the analyzer to take 10 sweeps. This time the computer receives an interrupt after the last sweep. The computer sits in a loop (lines 330 and 340) and waits until the analyzer signals completion of the TAKE SWEEP command. In this segment of the program, you should not see the display "freeze" at all. Immediately after it receives the interrupt, the computer puts the analyzer back into swept mode. This method of sensing the end of a TAKE SWEEP command via an interrupt is more time-efficient than the polling method previously used because the computer can be doing something else during the 10 sweeps.

To use the sweep hold mode, modify line 140 to "SW2" (instead of "SW0;CS;RM16;") and delete lines 150, 170, 180, and 190. The program will wait at line 200 until the 10 sweeps are completed. Whenever practical, use the service request interrupt to sense the end of a TAKE SWEEP command. In fact, you can use the time to do plotting or printing of data, instead of sitting in a loop. Service requests are useful for other events, as demonstrated by the next program.

Table 1. HP 8757D/E Status Byte Descriptions

STATUS BYTE (#1)								
BIT #	7	6	5	4	3	2	1	0
Decimal Value	128	64	32	16	8	4	2	1
Function	N/A	Request Service (SRQ)	SRQ on HP-IB Syntax Error	SRQ on Operation Complete (Sweep, Plot or Print)	SRQ on Softkey Only Pressed	SRQ on Change in Extended Status Byte	SRQ on Numeric Entry Completed (HP-IB or Front Panel)	SRQ on Any Front Panel Key Pressed
EXTENDED STATUS BYTE (#2)								
BIT #	7	6	5	4	3	2	1	0
Decimal Value	128	64	32	16	8	4	2	1
Function	N/A	SRQ on Detector Uncal	SRQ on Front Panel Preset or Power-on	SRQ on Limit Test Failed ¹	SRQ on Action Requested not possible	SRQ on Knob Activity	SRQ on Operation Failed ¹	SRQ on Self Test Failure

1. HP 8757D only.

Program 8: programming the softkeys

The HP 8757D/E has eight screen-labeled softkeys that make your measurements faster and easier. Under HP-IB control, you can re-label the softkeys with any annotation and sense when they are pressed.

Use the softkeys to branch to special measurement programs. By making full use of the softkeys, your automatic system may not need a normal computer keyboard at all, making it as easy to use as a manual instrument.

Program 8 listing

```

10 REM $INCLUDE: 'QBSETUP'
20 CLS
30 Isc& = 7
40 Sna& = 716
50 CALL IOTIMEOUT(Isc&, 10!):
  IF PCIB.ERR <> NOERR THEN ERROR PCIB.BASERR
60 CALL IOABORT(Isc&):
  IF PCIB.ERR <> NOERR THEN ERROR PCIB.BASERR
70 CALL IOCLEAR(Isc&):
  IF PCIB.ERR <> NOERR THEN ERROR PCIB.BASERR
80 PEN OFF
90 A$ = "IP" GOSUB IOOUTS
100 A$ = "CS RM8" GOSUB IOOUTS
110 A$ = "WK1 CAL1" GOSUB IOOUTS
120 A$ = "WK2 TEST1" GOSUB IOOUTS
130 A$ = "WK3 CAL2" GOSUB IOOUTS
140 A$ = "WK4 TEST2" GOSUB IOOUTS
150 A$ = "WK8 ABORT" GOSUB IOOUTS
160 PRINT "SOFT KEYS LOADED"
170 CALL IOPEN(Isc&, 0)
180 ON PEN GOSUB Srq.recv
190 PEN ON
200 Wait.srq: '
210 IF Keycode <> 41 THEN GOTO Wait.srq
220 PEN OFF

```

```

230 END
240 Srq.recv: '
250 CALL IOS POLL(Sna&, Intr.bit%):
  IF PCIB.ERR <> NOERR THEN ERROR PCIB.BASERR
260 A$ = "OK" GOSUB IOOUTS
270 CALL IOENTER(Sna&, Keycode)
280 SELECT CASE Keycode: CASE 32
290 CLS : LOCATE 12, 29: PRINT "Calibration #1"
300 CASE 8
310 CLS : LOCATE 12, 29: PRINT "Test #1"
320 CASE 0
330 CLS : LOCATE 12, 29: PRINT "Calibration #2"
340 CASE 16
350 CLS : LOCATE 12, 29: PRINT "Test #2"
360 CASE 41
370 CLS : LOCATE 12, 29: PRINT "Abort"
380 CASE ELSE
390 CLS : LOCATE 12, 29: PRINT "****Undefined****"
400 END SELECT
410 RETURN
420 IOOUTS: CALL IOOUTPUTS(Sna&, A$, LEN(A$))
430 IF PCIB.ERR <> NOERR THEN ERROR PCIB.BASERR
440 RETURN

```

Program 8 explanation

- Line 10 Call the QuickBASIC initialization file "QBSETUP".
- Line 20 Clear the computer CRT.
- Line 30 Assign the interface select code to a variable.
- Line 40 Assign the address of the analyzer to a variable.
- Line 50 Define a system timeout of 10 seconds. Perform error trapping.
- Line 60 Abort any HP-IB transfers. Perform error trapping.

Line 70 Clear the HP-IB interface of the analyzer. Perform error trapping.

Line 80 HP-IB service requests are implemented as lightpen events. This statement disables any lightpen event trapping.

Line 90 Preset the analyzer and source.

Line 100 Set the request mask to 8 (bit 3). See table 1 for the description of the status bytes.

Line 110 Label softkey 1 with "CAL 1". Softkey 1 is the softkey at the top of the CRT.

Line 120 Label softkey 2 with "TEST 1".

Line 130 Label softkey 3 with "CAL 2".

Line 140 Label softkey 4 with "TEST 2".

Line 150 Label softkey 8 with "ABORT".

Line 160 Print a message to the user.

Line 170 Enable the HP-IB interface to detect HP-IB service requests and process the interrupt as ON PEN events.

Line 180 Line label for routine that is executed when an interrupt is detected.

Line 190 Enable HP-IB service request interrupt event trapping.

Line 200 Line label for routine that waits for an interrupt.

Line 210 If the last softkey pressed was not the "Abort" key (softkey 8, key code 41), continue looping.

Line 220 Disable HP-IB service request interrupt event trapping.

Line 230 End program execution.

Line 240 Line label for routine that services the interrupts.

Line 250 Serial poll the analyzer. Reading the status byte of the analyzer clears the SRQ. The CLEAR STATUS (CS) command could also be used. Perform error trapping.

Line 260 Command the analyzer to output the key code of the last key pressed.

Line 270 Read the key code.

Line 280 Multi-way branch on key code value. When lines are labeled with numbers in QuickBASIC, "SELECT CASE ... CASE" for the first case must occur on the same line and be separated by a statement separator. If the key code is 32, then softkey 1 was pressed.

Line 290 Move to row 12, column 29, on the computer CRT and print an appropriate message.

Line 300 If the key code is 8, then softkey 2 was pressed.

Line 310 Move to row 12, column 29, and print an appropriate message.

Line 320 If the key code is 0, then softkey 3 was pressed.

Line 330 Move to row 12, column 29, and print an appropriate message.

Line 340 If the key code is 16, then softkey 4 was pressed.

Line 350 Move to row 12, column 29, and print an appropriate message.

Line 360 If the key code is 41, then softkey 8 was pressed.

Line 370 Move to row 12, column 29, print an appropriate message, and go to the end of the program.

Line 380 If the key code doesn't match any of the preceding codes, another key was pressed. In this case, the key code has to be for softkey 5, 6, or 7 (key codes 14, 38, or 40) since these are the only other keys that can interrupt the computer.

Line 390 Move to row 12, column 29, and print an appropriate message.

Line 400 End of multi-way branch.

Line 410 Return from subroutine.

Line 420 Define a subroutine that outputs commands to the analyzer.

Line 430 Perform error trapping.

Line 440 Return from the subroutine.

Running program 8

1. Clear the computer CRT and type in the program.
2. Press [ALT] [R] [S] on the computer.
3. After the computer presets the analyzer and source, it writes the softkey labels on the analyzer CRT. The analyzer writes the first key label and blanks the other softkey labels. Softkeys 5, 6, and 7 remain blank because they are not given new labels.
4. Press any key on the analyzer. Pressing a softkey causes a message to be printed on the computer CRT. Softkeys 5, 6, and 7 generate an interrupt, even though they weren't labeled. No other keys of the analyzer generate an interrupt, because of the SRQ mask specified.

Because the analyzer was left in remote mode, it didn't respond to any keys pressed on its front panel. In some applications it is useful to put the analyzer into local operation, so that it can be controlled from the front panel and still generate interrupts whenever a key is pressed.

Program 9: CRT graphics

For applications requiring diagrams, drawings, or special limit lines, the CRT of the analyzer may be used as a plotter.

This program draws a connection diagram for a hypothetical test system measuring an amplifier. It will blank the analyzer's standard display containing the graticule, annotation, and softkeys so that we have a blank CRT. Figure 2 shows what the CRT should look like when the program is done.

For fast, easy-to-use graphics, the graphics memory of the HP 8757D/E is divided into seven "pages" of 500 words. One vector requires two words. Each of the pages may be selected to receive data, and turned on and off independently. You can keep different drawings in each of the graphics memory pages and simply turn on the drawing you need by turning on the appropriate page. Each page may also be erased independently.

To use the graphics capability of the HP 8757D/E, first define the passthru address to be one less than the analyzer's control address. If the analyzer's address is 16, its graphics address is 15. To the computer, the CRT of the analyzer looks like a plotter connected to the 8757 SYSTEM INTERFACE.

Program 9 listing

```

10  REM $INCLUDE: 'QB4SETUP'
20  CLS
30  ISC& = 7
40  Sna& = 716
50  Passthru& = 717
60  CALL IOTIMEOUT(ISC&, 10!):
    IF PCIB.ERR <>NOERR THEN ERROR PCIB.BASERR
70  CALL IOABORT(ISC&):
    IF PCIB.ERR <>NOERR THEN ERROR PCIB.BASERR
80  CALL IOCLEAR(ISC&):
    IF PCIB.ERR <>NOERR THEN ERROR PCIB.BASERR
90  A$ = "IP BL5 PT15" GOSUB IOOUTS
100 A$ = "EP; GP1,1; DF" GOSUB IOOUTSP
110 A$ = "SP 9" GOSUB IOOUTSP
120 FOR Col = 0 TO 29
130 A$ = "PU;PA" +STR$(Col * 100) +",0;PD;PA"
    +STR$(Col * 100) +",2000;" GOSUB IOOUTSP
140 NEXT Col
150 FOR Row = 0 TO 20
160 A$ = "PU;PA 0," +STR$(Row * 100) +";PD;PA 2900,"
    +STR$(Row * 100) +";" GOSUB IOOUTSP
170 NEXT Row
180 A$ = "SP 1" GOSUB IOOUTSP
190 A$ = "PU; PA 600,1600; PD" GOSUB IOOUTSP
200 A$ = "SI0.28,0.34; LBCONNECTION DIAGRAM"
    +CHR$(3): GOSUB IOOUTSP
210 A$ = "PU; PA 1200,250; PD" GOSUB IOOUTSP
220 A$ = "SI0.28,0.34; LBDUT" +CHR$(3): GOSUB
    IOOUTSP
230 A$ = "PU; PA 300,800; PD; PA
    1100,800,1100,1100,300,1100,300,800" GOSUB
    IOOUTSP
240 A$ = "PU; PA 800,800; PD; PA 800,1100" GOSUB
    IOOUTSP
250 A$ = "PU; PA 1500,800; PD; PA
    2300,800,2300,1200,1500,1200,1500,800" GOSUB
    IOOUTSP
260 A$ = "PU; PA 1950,800; PD; PA 1950,1200" GOSUB
    IOOUTSP
270 A$ = "PU; PA 875,850; PD; PA 875,500,1200,500"
    GOSUB IOOUTSP
280 A$ = "PU; PA 1400,500; PD; PA
    2050,500,2050,850" GOSUB IOOUTSP
290 A$ = "PU; PA 1200,400; PD; PA
    1400,500,1200,600,1200,400" GOSUB IOOUTSP
300 A$ = "PU; PA 0,0" GOSUB IOOUTSP
310 END
320 IOOUTS: CALL IOOUTPUTS(Sna&, A$, LEN(A$))
330 IF PCIB.ERR <>NOERR THEN ERROR PCIB.BASERR
340 RETURN
350 IOOUTSP: CALL IOOUTPUTS(Passthru&, A$, LEN(A$))
360 IF PCIB.ERR <>NOERR THEN ERROR PCIB.BASERR
370 RETURN

```

CONNECTION DIAGRAM

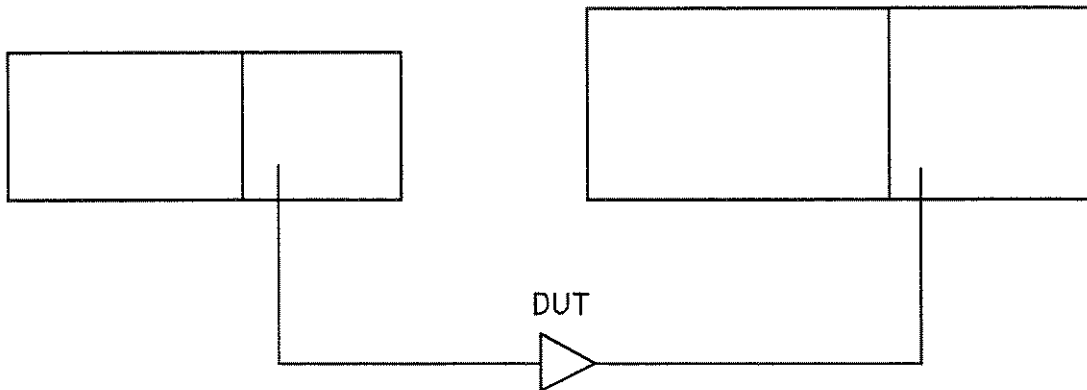

Figure 2. The CRT Graphics Display

Program 9 explanation

Line 10 Call the QuickBASIC initialization file "QBSETUP".

Line 20 Clear the computer CRT.

Line 30 Assign the interface select code to a variable.

Line 40 Assign the address of the analyzer to a variable.

Line 50 Assign the passthru address of the analyzer to a variable.

Line 60 Define a system timeout of 10 seconds. Perform error trapping.

Line 70 Abort any HP-IB transfers. Perform error trapping.

Line 80 Clear the HP-IB interface of the analyzer. Perform error trapping.

Line 90 Preset the analyzer and blank the CRT display. Define the CRT graphics as the target of passthru commands. The graphics address is always one less than the analyzer's HP-IB address.

Line 100 Erase all graphics pages. Turn on graphics page 1 to ensure that the graphics start in it. Set the color selection to default (monochrome) colors.

Line 110 Select to plot with pen 9, the lowest intensity for the analyzer CRT.

Line 120 Repeat a loop 29 times to draw part of the grid.

Line 130 Draw a vertical line down the CRT.

Line 140 End of the loop.

Line 150 Repeat loop 20 times to draw the horizontal part of the grid.

Line 160 Draw a horizontal line across the CRT.

Line 170 End of the loop.

Line 180 Select to plot with pen 1, the brightest intensity for the analyzer CRT.

Line 190 Move the pen to title the display.

Line 200 Specify the width and height of each character, indicate what the title is, terminate the title with an end of text character.

Line 210 Move the pen to label the DUT.

Line 220 Specify the width and height of each character, indicate what the title is, terminate the title with an end of text character.

Line 230 Move the pen and draw the outline of the source.

Line 240 Draw the plug-in of the source.

Line 250 Move the pen and draw the outline of the analyzer.

Line 260 Draw the CRT of the analyzer.

Line 270 Draw the connections from the source to the DUT.

Line 280 Draw the connections from the DUT to the analyzer.

Line 290 Draw the DUT (an amplifier.)

Line 300 Move to the bottom left corner of the CRT.

Line 310 End program execution.

Line 320 Define a subroutine that outputs commands to the analyzer.

Line 330 Perform error trapping.

Line 340 Return from the subroutine.

Line 350 Define a subroutine that addresses the analyzer as a plotter.

Line 360 Perform error trapping.

Line 370 Return from the subroutine.

Running program 9

1. Clear the computer CRT and type in the program.
2. Press [ALT] [R] [S] on the computer.
3. After the analyzer and source are preset, the CRT will be blanked. First a grid is plotted on the CRT. While this isn't necessary for our connection diagram, it does give you a good indication of where the X and Y coordinates are on the analyzer's CRT.
4. The labeling is added. The labels "CONNECTION DIAGRAM" and "DUT" are done using the analyzer CRT's internal character set.
5. All of the lines are plotted on the analyzer's CRT. If brighter lines are desired, draw each line twice or select a different pen number.

In this example, only graphics page 1 is used. You can independently control up to 7 separate pages of graphics information. If you write too much information onto one page, it overflows onto the next page.

When a graphics page is selected, the first location of memory that receives information (identified by the "pointer") is reset to the beginning of the page. Thus, as information is written onto the page, the old information is destroyed. If we were plotting a line, this would appear as a new trace overwriting an old one.

Program 10: learning the instrument state

Being able to save a specific instrument state is helpful when it is needed several times in a test or measurement procedure. You can save the instrument state by manually logging the important analyzer and source parameters, such as start/stop frequency, sweep time, number of trace points, scale per division, and display format, then replace them at the appropriate time. A simpler approach is to save the instrument state in one of the nine internal save/recall registers of the analyzer/source combination, then recall it when needed.

You have two additional options with HP-IB: the interrogate function and the learn string. With the output interrogated parameter function (OP), you can selectively interrogate the values of all functions that have numeric values (such as frequency and number of trace points). This function operates the same way in both the analyzer and the source. It is illustrated in program 3 where the source start and stop frequencies are interrogated in lines 110 through 140.

For a more thorough approach, use the learn string functions of the analyzer and source. The learn string describes the present instrument state and is similar to one of the internal save/recall registers. For the analyzer, the learn string also includes all of the global parameters, but does not include limit line information. Once an instrument state is learned, the analyzer and source states can be restored at any later time. The following program demonstrates how to both learn and restore the instrument states of the HP 8757D/E and the HP 8350B Sweeper by using their learn string functions. If you use the HP 8340B, 8341B, or 8360 series Synthesized Sweepers, perform the modification described at the end of "Running program 10."

Program 10 listing

```
10 REM $INCLUDE: 'QBSETUP'
20 CLS
30 Maxsna% = 300
40 Maxswpr% = 90
50 ISC% = 7
60 Sna% = 716
70 Passthru% = 717
80 CALL IOTIMEOUT(ISC%, 10):
  IF PCIB.ERR <> NOERR THEN ERROR PCIB.BASERR
90 CALL IOABORT(ISC%):
  IF PCIB.ERR <> NOERR THEN ERROR PCIB.BASERR
100 CALL IOCLEAR(ISC%):
  IF PCIB.ERR <> NOERR THEN ERROR PCIB.BASERR
110 A$ = "IP" GOSUB IOOUTS
120 A$ = "PT19;" GOSUB IOOUTS
130 CALL IOLOCAL(Sna%):
  IF PCIB.ERR <> NOERR THEN ERROR PCIB.BASERR
140 INPUT "SET UP SYSTEM,PRESS ENTER", B$
150 Match$ = CHR$(10):
  CALL IOMATCH(ISC%, Match$, 0): IF PCIB.ERR <>
  NOERR THEN ERROR PCIB.BASERR
```

```
160 A$ = "OL" GOSUB IOOUTS
170 Actual% = 0
180 Lsna$ = SPACE$(Maxsna%)
190 CALL IOENTERS(Sna%, Lsna$, Maxsna%, Actual%):
  IF PCIB.ERR <> NOERR THEN ERROR PCIB.BASERR
200 A$ = "OL" GOSUB IOOUTSP
210 Actual% = 0
220 Lswpr$ = SPACE$(Maxswpr%)
230 CALL IOENTERS(Passthru%, Lswpr$, Maxswpr%,
  Actual%):
  IF PCIB.ERR <> NOERR THEN ERROR PCIB.BASERR
240 CALL IOMATCH(ISC%, Match$, 1):
  IF PCIB.ERR <> NOERR THEN ERROR PCIB.BASERR
250 A$ = "IP" GOSUB IOOUTS
260 INPUT "TO RESTORE SETUP,PRESS ENTER", B$
270 A$ = "IL" + Lsna$: GOSUB IOOUTS
280 A$ = "IL" + Lswpr$: GOSUB IOOUTSP
290 A$ = "" GOSUB IOOUTS
300 CALL IOLOCAL(Sna%):
  IF PCIB.ERR <> NOERR THEN ERROR PCIB.BASERR
310 END
320 IOOUTS: CALL IOOUTPUTS(Sna%, A$, LEN(A$))
330 IF PCIB.ERR <> NOERR THEN ERROR PCIB.BASERR
340 RETURN
350 IOOUTSP: CALL IOOUTPUTS(Passthru%, A$, LEN(A$))
360 IF PCIB.ERR <> NOERR THEN ERROR PCIB.BASERR
370 RETURN
```

Program 10 explanation

- Line 10 Call the QuickBASIC initialization file "QBSETUP".
- Line 20 Clear the computer CRT.
- Line 30 Define the maximum number of characters for the analyzer learn string.
- Line 40 Define the maximum number of characters for the learn string of the source.
- Line 50 Assign the interface select code to a variable.
- Line 60 Assign the address of the analyzer to a variable.
- Line 70 Assign the passthru address of the analyzer to a variable.
- Line 80 Define a system timeout of 10 seconds. Perform error trapping.
- Line 90 Abort any HP-IB transfers. Perform error trapping.
- Line 100 Clear the HP-IB interface of the analyzer. Perform error trapping.
- Line 110 Preset the analyzer and the source.
- Line 120 Tell the analyzer which device is controlled through the passthru address. Address 19 belongs to the source.
- Line 130 Set the analyzer and source to local mode. Perform error trapping.
- Line 140 Prompt the user to set up the system. Then wait for the [ENTER] key to be pressed.

Line 150 Disable character matching for the linefeed. The analyzer learn string is 300 contiguous binary bytes (150 for the HP 8757E) that does not end with a cr/lf (since this could actually be part of the learn string information).

Line 160 Program the analyzer to output its learn string.

Line 170 Initialize the variable specifying the number of elements actually read.

Line 180 Allocate string space large enough to hold the learn string of the analyzer (150 bytes).

Line 190 Read the analyzer learn string into the string "Lsna\$".

Line 200 Program the source to output its learn string.

Line 210 Initialize the variable specifying the number of elements actually read.

Line 220 Allocate string space large enough to hold the learn string of the source.

Line 230 Read the source learn string into the string "Lswpr\$". The computer must read the entire source learn string which, for the HP 8350B Sweeper, is 90 bytes long.

Line 240 Enable character matching; this results in termination on a linefeed when a string is read.

Line 250 Preset the analyzer and source to clear the instrument states.

Line 260 Prompt the user, then wait for the [ENTER] key to be pressed.

Line 270 Program the analyzer to accept its learn string, then send it.

Line 280 Program the source to accept its learn string, then send it.

Line 290 Re-address the analyzer to exit passthru mode and continue sweeping.

Line 300 Set the analyzer and source to local mode.

Line 310 End program execution.

Line 320 Define a subroutine that outputs commands to the analyzer.

Line 330 Perform error trapping.

Line 340 Return from the subroutine.

Line 350 Define a subroutine that outputs commands to the source through the passthru address of the analyzer.

Line 360 Perform error trapping.

Line 370 Return from the subroutine.

Running program 10

1. Clear the computer CRT and type in the program.
2. Press [ALT] [R] [S] on the computer.
3. When the computer stops and displays:
SET UP SYSTEM, PRESS CONTINUE.
Adjust the analyzer and source to a preferred instrument state, then press the [ENTER] key on the computer.
4. The computer will save the learn strings of both the analyzer and the source. After completing this, the analyzer and source will be preset to destroy your original instrument state.
5. The computer stops and displays:
TO RESTORE SETUP, PRESS CONTINUE.
Press the [ENTER] key. The computer will restore your original instrument state via the two learn strings. Verify on the displays of the analyzer and the source that your state has been restored.

This example is designed to work with the HP 8350B Sweep Oscillator, which has a learn string of 90 bytes. The program can be easily modified to work with the HP 8340B and 8341B Synthesized Sweepers which have learn strings 123 bytes in length. To do this, change line 40 to be:

```
40 Maxswpr% = 123
```

To work with the HP 8360 Series Synthesized Sweeper, the modifications are more extensive due to its variable length learn string. To do this, change and/or add the following lines:

```
40 Maxswpr% = 700
212 Lswpr0$ = SPACE$(3)
214 CALL IOENTERS(Passthru&, Lswpr0$, 3, Actual%):
IF PCIB.ERR <> NOERR THEN ERROR PCIB.BASERR
216 Maxswpr% = 256 * ASC(MID$(Lswpr0$, 2)) +
ASC(MID$(Lswpr0$, 3))
218 Actual% = 0
280 A$ = "IL" + Lswpr0$ + Lswpr$: GOSUB IOOUTSP
```

The following should explain the above actions:

- Line 212 Allocate string space large enough to hold the header portion of the HP 8360 learn string (3 bytes).
- Line 214 Read the 3 header bytes. Bytes 2 and 3 indicate the number of bytes to follow.
- Line 216 Compute the number of bytes to follow and change Maxswpr% to reflect this.
- Line 220 Allocate string space large enough to hold the remainder of the HP 8360 learn string.
- Line 230 Read the remainder of the HP 8360 learn string.
- Line 280 Program the source to accept its learn string, then send it. For the HP 8360, the complete learn string is Lswpr0\$ + Lswpr\$.

Program 11: guided instrument setup with CRT graphics

As was illustrated by program 9, it is possible to utilize the CRT of the HP 8757D/E as a plotter. This program goes one step further by utilizing the CRT to create a simple connection diagram which may be recalled by the user, at any time, from the front panel of the analyzer.

This program draws the same hypothetical connection diagram that was drawn by program 9. It blanks most of the analyzer's standard display, including the graticle and all annotation except the soft keys. In addition, it adds one softkey under both the save and the recall hardkey menus. This softkey will allow the user to toggle the state of the CRT graphics off and on.

To use the graphics off/on capability of the HP 8757D/E, change "BL5" in line 90 of program 9 to "BLA", and make the necessary changes in the size of the background grid. These, and other changes are illustrated in the following listing.

The same principle can be used to save anything stored to disk on the HP 8757D in the first seven pages of user graphics. By having the softkeys available, the user can store CRT graphics onto a disk for later recall.

Program 11 listing

```
10 REM $INCLUDE: 'QBSETUP'
20 CLS
30 ISC& = 7
40 Sna& = 716
50 Passthru& = 717
60 CALL IOTIMEOUT(ISC&, 10!):
  IF PCIB.ERR <>NOERR THEN ERROR PCIB.BASERR
70 CALL IOABORT(ISC&):
  IF PCIB.ERR <>NOERR THEN ERROR PCIB.BASERR
80 CALL IOCLEAR(ISC&):
  IF PCIB.ERR <>NOERR THEN ERROR PCIB.BASERR
90 A$ = "IP BLA PT15" GOSUB IOOUTS
100 A$ = "EP; GP1,1; DEC" GOSUB IOOUTSP
110 A$ = "SP 6" GOSUB IOOUTSP
120 FOR Col = 0 TO 25
130 A$ = "PU;PA" +STR$(Col * 100) +",0;PD;PA"
  +STR$(Col * 100) +",2000;" GOSUB IOOUTSP
140 NEXT Col
150 FOR Row = 0 TO 20
160 A$ = "PU;PA 0," +STR$(Row * 100) +";PD;PA 2500,"
  +STR$(Row * 100) +";" GOSUB IOOUTSP
170 NEXT Row
180 A$ = "SP 8" GOSUB IOOUTSP
190 A$ = "PU; PA 600,1600; PD" GOSUB IOOUTSP
200 A$ = "SI0.28,0.34; LBCONNECTION DIAGRAM"
  +CHR$(3): GOSUB IOOUTSP
210 A$ = "PU; PA 1200,250; PD" GOSUB IOOUTSP
220 A$ = "SI0.28,0.34; LBDUT" +CHR$(3): GOSUB
  IOOUTSP
230 A$ = "PU; PA 300,800; PD; PA
  1100,800,1100,1100,300,1100,300,800" GOSUB
  IOOUTSP
240 A$ = "PU; PA 800,800; PD; PA 800,1100" GOSUB
  IOOUTSP
250 A$ = "PU; PA 1500,800; PD; PA 2300,
  800,2300,1200,1500,1200,1500,800" GOSUB IOOUTSP
```

```
260 A$ = "PU; PA 1950,800; PD; PA 1950,1200" GOSUB
  IOOUTSP
270 A$ = "PU; PA 875,850; PD; PA 875,500,1200,500"
  GOSUB IOOUTSP
280 A$ = "PU; PA 1400,500; PD; PA
  2050,500,2050,850" GOSUB IOOUTSP
290 A$ = "PU; PA 1200,400; PD; PA
  1400,500,1200,600,1200,400" GOSUB IOOUTSP
300 A$ = "PU; PA 0,0" GOSUB IOOUTSP: A$ = "" GOSUB
  IOOUTS
310 CALL IOLOCAL(Sna&):
  IF PCIB.ERR <>NOERR THEN ERROR PCIB.BASERR
320 END
330 IOOUTS: CALL IOOUTPUTS(Sna&, A$, LEN(A$))
340 IF PCIB.ERR <>NOERR THEN ERROR PCIB.BASERR
350 RETURN
360 IOOUTSP: CALL IOOUTPUTS(Passthru&, A$, LEN(A$))
370 IF PCIB.ERR <>NOERR THEN ERROR PCIB.BASERR
380 RETURN
```

Program 11 explanation

- Line 10 Call the QuickBASIC initialization file "QBSETUP".
- Line 20 Clear the computer screen.
- Line 30 Assign the interface select code to a variable.
- Line 40 Assign the address of the HP 8757D/E to a variable.
- Line 50 Assign the passthru address of the HP 8757D/E to a variable.
- Line 60 Define a system timeout of 10 seconds. Perform error trapping.
- Line 70 Abort any HP-IB transfers. Perform error trapping.
- Line 80 Clear the HP-IB interface of the HP 8757D/E. Perform error trapping.
- Line 90 Preset the analyzer and blank all the CRT display except the softkeys. Define the CRT graphics as the target of passthru commands. The graphics address is always one less than the analyzer's HP-IB address.
- Line 100 Erase all graphics pages. Turn graphics page 1 on to ensure that the graphics start in it.
- Line 110 Select to plot with pen 6, the lowest intensity for the analyzer CRT.
- Line 120 Repeat a loop 25 times to draw vertical part of the grid.
- Line 130 Draw a vertical line down the CRT screen.
- Line 140 End of the loop.
- Line 150 Repeat loop 20 times to draw horizontal part of the grid.
- Line 160 Draw a horizontal line across the CRT.
- Line 170 End of the loop.

Line 180 Select to plot with pen 8, the brightest intensity for the analyzer CRT.

Line 190 Move the pen to title the display.

Line 200 Specify the width and height of each character, indicate what the title is, terminate the title with an end of text character.

Line 210 Move the pen to label the device under test.

Line 220 Specify the width and height of each character, indicate what the title is, terminate the title with an end of text character.

Line 230 Move the pen and draw the outline of the source.

Line 240 Draw the plug-in of the source.

Line 250 Move the pen and draw the outline of the analyzer.

Line 260 Draw the CRT of the analyzer.

Line 270 Draw the connections from the source to the DUT.

Line 280 Draw the connections from the DUT to the analyzer.

Line 290 Draw the DUT (an amplifier.)

Line 300 Move to the bottom left corner of the CRT.

Line 310 Place the analyzer and the source in local mode. Perform error trapping.

Line 320 End program execution.

Line 330 Define a subroutine that outputs commands to the analyzer.

Line 340 Perform error trapping.

Line 350 Return from the subroutine.

Line 360 Define a subroutine that addresses the analyzer as a plotter.

Line 370 Perform error trapping.

Line 380 Return from the subroutine.

Running program 11

1. Clear the screen of the computer and type in the program.
2. Press [ALT] [R] [S] on the computer.
3. After the analyzer and source are preset, the CRT is blanked, except for softkeys. First a grid is plotted on the CRT. While this isn't necessary for our connection diagram, it does give you a good indication of where the X and Y coordinates are on the analyzers' CRT.
4. The labelling is added. The labels "CONNECTION DIAGRAM" and "DUT" are written using the analyzer CRT's internal character set.
5. All of the lines are plotted on the analyzer's CRT. If brighter lines are desired, draw each line twice or, select different pen numbers.
6. The analyzer is placed in local mode with the front panel and the softkeys active. To access the graphics on/off capability, press [SAVE] on the analyzer to show the save menu. Press the [STORE TO DISK] softkey. Note the [GRAPHIC ON/OFF] softkey, it does not appear unless the "BLA" command is used. Press the [GRAPHIC ON/OFF] softkey so that it is "off." The connection diagram will now disappear from the CRT display. Press the [GRAPHIC ON/OFF] softkey again and the diagram will reappear. If you store this setup to the external disk drive at this time, the analyzer will remember this graphics on/off mode later upon recall from disk.

Table 2. Alphabetical Listing of HP 8757D/E Programming Codes (1 of 3)

Code	Action	Code	Action
A0	Averaging off	CLS	Color list, salmon ¹
AB	A/B ratio measurement	CLW	Color list, white ¹
AC	A/C ratio measurement ²	CLY	Color list, yellow ¹
AFd	Averaging on and factor d	CN	Cursor to minimum
ANm	Adaptive Normalization on/off	COBd	Brightness adjust, one color ¹
AR	A/R ratio measurement	COCd	Color adjust, one color ¹
AS	Autoscale	COTd	Tint adjust, one color ¹
AZ2	Autozero the DC detectors once	CR	C/R ratio measurement ²
AZm	Autozero repeat on/off of the DC detectors	CS	Clear status bytes
BA	B/A ratio measurement	CTm	Auto system calibration on/off
BC	B/C ratio measurement ²	CUm	Cursor on/off
BFm	Plotter buffer on/off ³	CWm	CW mode on/off
BL0	Restore CRT to normal mode	CX	Cursor to maximum
BL1	Blank frequency labels (secure frequency mode, frequency labels cannot be restored)	DAd	Detector A amplitude offset set to d
BL2	Blank all labels	DBd	Detector B amplitude offset set to d
BL3	Blank active channel trace	DCd	Detector C amplitude offset set to d ²
BL4	Blank softkey labels	DEC	Set default colors ¹
BL5	Blank all (except user CRT graphics)	DFA	Set disk format to ASCII ¹
BL6	Blank title	DFB	Set disk format to binary ¹
BL7	Blank mode labels	DFE	Set Disk format to extended binary ¹
BL8	Blank the active entry area	DHm	Display Hold on/off of the active channel trace
BL9	Blank the limit lines	DIAd	Set disk HP-IB address ¹
BLA	Blank all (except user CRT graphics and softkeys)	DIUd	Set disk unit number ¹
BR	B/R ratio measurement	DIVd	Set disk volume number ¹
BTNd	Overall display brightness	DLF	Delete file from disk ¹
BW	Display the search bandwidth on the CRT ¹	DM0	All inputs set to DC detection
C0	Channel off	DM1	All inputs set to AC detection
C1	Channel 1 on/active	DN	Step down (decrement)
C2	Channel 2 on/active	DOAd	Measure Detector A amplitude offset
C3	Channel 3 on/active ¹	DOBd	Measure Detector B amplitude offset
C4	Channel 4 on/active ¹	DOCd	Measure Detector C amplitude offset ²
CA	C/A ratio measurement ²	DORd	Measure Detector R amplitude offset
CB	C/B ratio measurement ²	DRd	Detector R amplitude offset set to d
CC1	Set channel 1 color ¹	DS0	Display trace data in log magnitude
CC2	Set channel 2 color ¹	DS1	Display trace data in standing wave ratio (SWR) format
CC3	Set channel 3 color ¹	DTSTPAs	Enter stop frequency for detector A
CC4	Set channel 4 color ¹	DTSTPBs	Enter stop frequency for detector B
CDm	Cursor delta on/off	DTSTPCs	Enter stop frequency for detector C ²
CGL	Set labels color ¹	DTSTPRs	Enter stop frequency for detector R
CGN	Set background color ¹	DTSTRAs	Enter start frequency for detector A
CGR	Set grid color ¹	DTSTRBs	Enter start frequency for detector B
CGW	Set warning label color ¹	DTSTRCs	Enter start frequency for detector C ²
CL	Perform system configuration of detectors and channels	DTSTRRs	Enter start frequency for detector R
CLB	Color list, black ¹	EO	Enter measured detector amplitude offset
CLG	Color list, green ¹	ER0	Erase all save/recall registers
CLL	Color list, blue ¹	FAs	Start frequency label
CLR	Color list, red ¹	FBs	Stop frequency label
		FD0	Format data ASCII

1. HP 8757D only

2. HP 8757D Option 001 only

3. Revision 3.1 or above for HP 8757E.

Table 9. Alphabetical Listing of HP 8757D/E Programming Codes (2 of 3)

Code	Action	Code	Action
FD1	Format data binary (HP BASIC compatible)	MU3	Display the reference menu
FD2	Format data extended ASCII	MU4	Display the cursor menu
FD3	Format data binary (PC compatible)	MU5	Display the average menu
FD4	Format data extended binary (HP BASIC compatible)	MU6	Display the calibration menu
FD5	Format data extended binary (PC compatible)	MU7	Display the special menu
FR0	Logarithmic (dB) cursor format ³	MU8	Display the system menu
FR1	SWR cursor format ³	MY	Display memory data
FSm	Step sweep on/off ^{3,4}	MZ	Manual calibration of DC detectors
FTAm	Detector A frequency on/off	NSm	Non-standard sweep mode on/off
FTBm	Detector B frequency on/off	OC	Output cursor value
FTCm	Detector C frequency on/off ²	OD	Output trace data
FTRm	Detector R frequency on/off	OE1	Output error status of display channel 1
IA	Input A absolute power measurement	OE2	Output error status of display channel 2
IB	Input B absolute power measurement	OI	Output identity
IC	Input C absolute power measurement ²	OK	Output keycode of last key pressed
ILs	Input Learn string	OL	Output learn string
IND	Initialize disk format ¹	OM	Output memory data
IP	Instrument preset	ON	Output normalized (measurement —memory) data
IR	Input R absolute power measurement	OPDO	Output measured detector amplitude offset
IX	External ADC input (AUX) voltage measurement ¹	OPxx	Output interrogated parameter value xx= AF, BW, DA, DB, DC, DR, RL, RP, SD, SL, SO, SP, SR, SS, ST
LE	Erase limit lines for active channel ⁵	OR	Output rotary knob value (-32768 ≤ value ≤ +32767)
LFA	Load instrument information file from disk ¹	OS	Output status bytes
LFC	Load CRT graphics file from disk ¹	OT1m	Control output #1 on/off
LFD	Load data trace file from disk ¹	OT2m	Control output #2 on/off
LFF	Load measurement file from disk. ¹	OV	Output CW value
LFH	Load instrument information file from disk and place instrument in hold mode. ¹	P1	Plot channel 1 trace on external plotter
LFI	Load instrument state file from disk ¹	P2	Plot channel 2 trace on external plotter
LFM	Load memory trace file from disk ¹	P3	Plot channel 3 trace on external plotter ¹
LFN	Load display trace file from disk. ¹	P4	Plot channel 4 trace on external plotter ¹
LFs	Enter limit test flat line data ⁵	PA	Plot all on external plotter
LL	Store lower limit line into memory ⁵	PBm	System interface control on/off
LPs	Enter limit test point data ⁵	PC	Plot labels on external plotter
LSs	Enter limit test sloped line data ⁵	PD	Plot custom plot
LTm	Limit line test on/off ⁵	PG	Plot grid on external plotter
LU	Store upper limit line into memory ⁵	PR1	Print all to monochrome printer, except softkeys and CRT graphics
M-	Display normalized data (measurement - memory)	PR2	Print tabular display data in monochrome
MDm	Modulation on/off	PR3	Print tabular marker/cursor data to external printer
ME	Display measurement data	PR4	Print all to color printer, except softkeys and CRT graphics ¹
MM	Display the channel menu(main menu)	PTd	Passthrough address set to d
MN	Display normalized data (same as M-)	PWRA	Execute a detector A power calibration
MOC	Monochrome display ¹	PWRB	Execute a detector B power calibration
MR	Marker (or cursor) to reference line	PWRC	Execute a detector C power calibration ²
MSm	Manual sweep mode on/off	PWRR	Execute a detector R power calibration
MU0	Display the measurement menu	R1	R/A ratio measurement
MU1	Display the display menu	R2	R/B ratio measurement
MU2	Display the scale menu		

1. HP 8757D only

2. HP 8757D Option 001 only

3. Revision 3.1 or above for HP 8757E.

4. HP 8340, HP 8341, or HP 8360 series synthesized sweeper only with 8757 SYSTEM INTER-FACE connected and active.

5. Limit line functions valid only for channels 1 or 2, HP 8757D only.

Table 9. Alphabetical Listing of HP 8757D/E Programming Codes (3 of 3)

Code	Action	Code	Action
R3	R/C ratio measurement ²	SR	Cursor search right ¹
RCn	Recall register n	SSd	Cursor search value set to d ¹
RLd	Reference level set to d	STd	Reference level step size set to d
RMd	Service request mask set to d	SUd	Specify custom plot according to d
RPq	Reference position set to vertical division q	SVn	Save register n
RS	Restart averaging	SW0	Non-swept mode; non-swept operation
SCd	Set cursor to horizontal position d	SW1	Swept mode; normal swept operation
SDd	Scale per division set to d	SW2	Sweep hold mode; non-swept mode with HP-IB bus hold off until completion of TSd
SFA	Store all instrument information to disk in file ¹	TCm	Continuous Temperature Compensation on/off
SFC	Store CRT graphics to disk in file ¹	TIFs	Title for file ¹
SFD	Store data trace to disk in file ¹	TSd	Take d sweeps, then hold display
SFI	Store instrument state to disk in file ¹	UP	Step up (increment)
SFM	Store memory trace to disk in file ¹	WKs	Write softkey label
SFN	Store normalized trace to disk in file ¹	WMs	Write to channel memory.
SKq	Select softkey q: q = 1 to 8	WTs	Write title, s is an ASCII string of up to 50 characters
SL	Cursor search left ¹	XAs	External detector cal value for detector A
SM	Store measurement into memory	XBs	External detector cal value for detector B
SN	Store normalized data (measurement - memory) into memory	XCs	External detector cal value for detector C ²
SOd	Smoothing set to d % of frequency span	XRs	External detector cal value for detector R
SPd	Number of points set to d: d=101, 201, 401, 801 ¹ , 1601 ¹		

1. HP 8757D only

2. HP 8757D Option 001 only (detector C)

NOTES: n = decimal integer 1 to 9
d = variable length numeric
m = 0 for off/1 for on
q = unique value
s = ASCII or binary string

HP-IB Programming Note

Introductory Programming Guide

for the HP 8757D/E Scalar Network Analyzer with the HP Vectra Personal Computer using Microsoft® QuickC 2.5

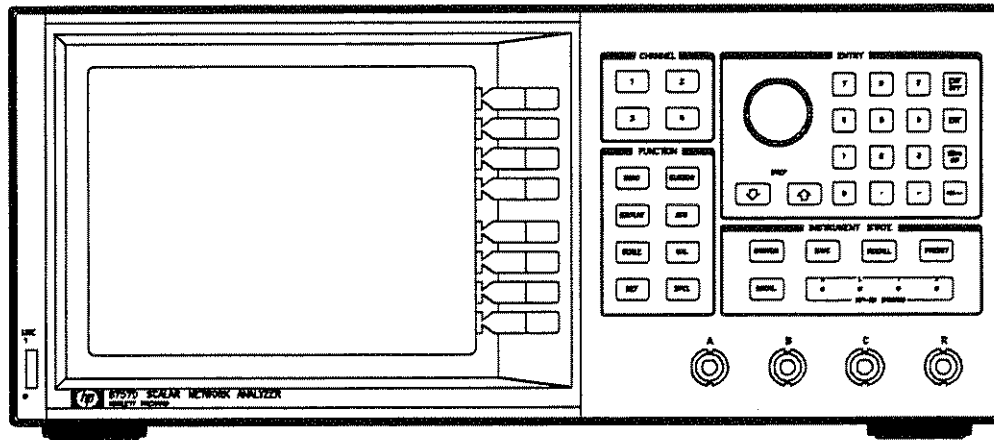

Introduction

This programming note describes the remote operation of the HP 8757D/E Scalar Network Analyzer with the HP Vectra Personal Computer (or IBM compatible) using the HP 82335A HP-IB Command Library and Microsoft QuickC 2.5. Included in this guide are several short programs that demonstrate the use of the HP 8757D/E with HP-IB commands, and a diagram of system connections for remote control.

The HP 8757D/E is a fully programmable analyzer capable of making magnitude-only transmission and reflection measurements over an RF and microwave frequency range of 10 MHz to 110 GHz. When used with an HP-IB computer, the analyzer's front panel may be remotely controlled, along with most softkey functions and some functions accessible only via HP-IB. The analyzer exerts control over a source (HP 8350B, 8340B/41B, or 8360), digital plotter (HP 7440A or 7550A/B), and printer (HP 2225A ThinkJet, 3630A PaintJet, or 2225B QuietJet Plus) connected to the 8757 SYSTEM INTERFACE.

Microsoft® is a U.S. registered trademark of Microsoft Corp.

This note assumes you are familiar with local (non-remote) operation of the HP 8757D/E. If not, refer to the operating manual. You should also be familiar with the HP Vectra Personal Computer (or compatible), particularly HP-IB operation using the HP 82335A HP-IB Command Library.

Sample programs included in this guide are:

- Program 1: Remote, Local, and Local Lockout.
- Program 2: Controlling the Front Panel.
- Program 3: Passthru Mode.
- Program 4: Cursor Operations.
- Program 5: Read a Single Value.
- Program 6: Trace Transfer.
- Program 7: Using the TAKE SWEEP Command.
- Program 8: Programming the Softkeys.
- Program 9: CRT Graphics.
- Program 10: Learning the Instrument State.
- Program 11: Guided Instrument Setup with CRT Graphics.

Reference information

The following texts provide additional information on the HP Interface Bus, the analyzer, the source, or the HP Vectra Personal Computer.

HP 8757D/E literature:

- *HP 8757D Operating Manual*
- *HP 8757D/E Operating Manual.*
- Programming Note: *Quick Reference Guide for the HP 8757D/E Scalar Network Analyzer.*

Source literature:

- Programming Note: *Quick Reference Guide for the HP 8350B Sweep Oscillator.*
- Programming Note: *Quick Reference Guide for the HP 8340B Synthesized Sweeper.*
- *HP 8360 Operating and Programming Reference Manual.*

HP Vectra Personal Computer literature:

- *HP 82335A HP-IB Command Library Manual.*
- *Microsoft QuickC: Up and Running.*
- *Microsoft QuickC: Tool Kit.*
- *C for Yourself.*

Equipment required

- 1 HP 8757D/E Scalar Network Analyzer.
- 1 HP 8350B Sweeper with plug-in or HP 8340B/41B Synthesized Sweeper or HP 8360 Series Synthesized Sweeper.
- 1 HP Vectra Personal Computer (or compatible) with Microsoft QuickC 2.5, HP 82335A HP-IB Interface Card, MS-DOS 3.3 or higher, and at least 512K bytes of memory.
- 1 HP 85027A/B/C/D/E Directional Bridge.
- 1 HP 11664A/E Detector or HP 85025A/B/D/E Detector. or HP 85037A/B Precision Detector with connector type to match bridge and test device.
- 1 Shielded open circuit with connector to mate with bridge.
- 1 Short circuit with connector to mate with bridge.
- 3 HP 11170C BNC cables, 122 cm. (48 inches). (4 are needed with HP 8340B/41B).
- 2 HP 10833A/B/C/D HP-IB cables.
- 1 Test device.

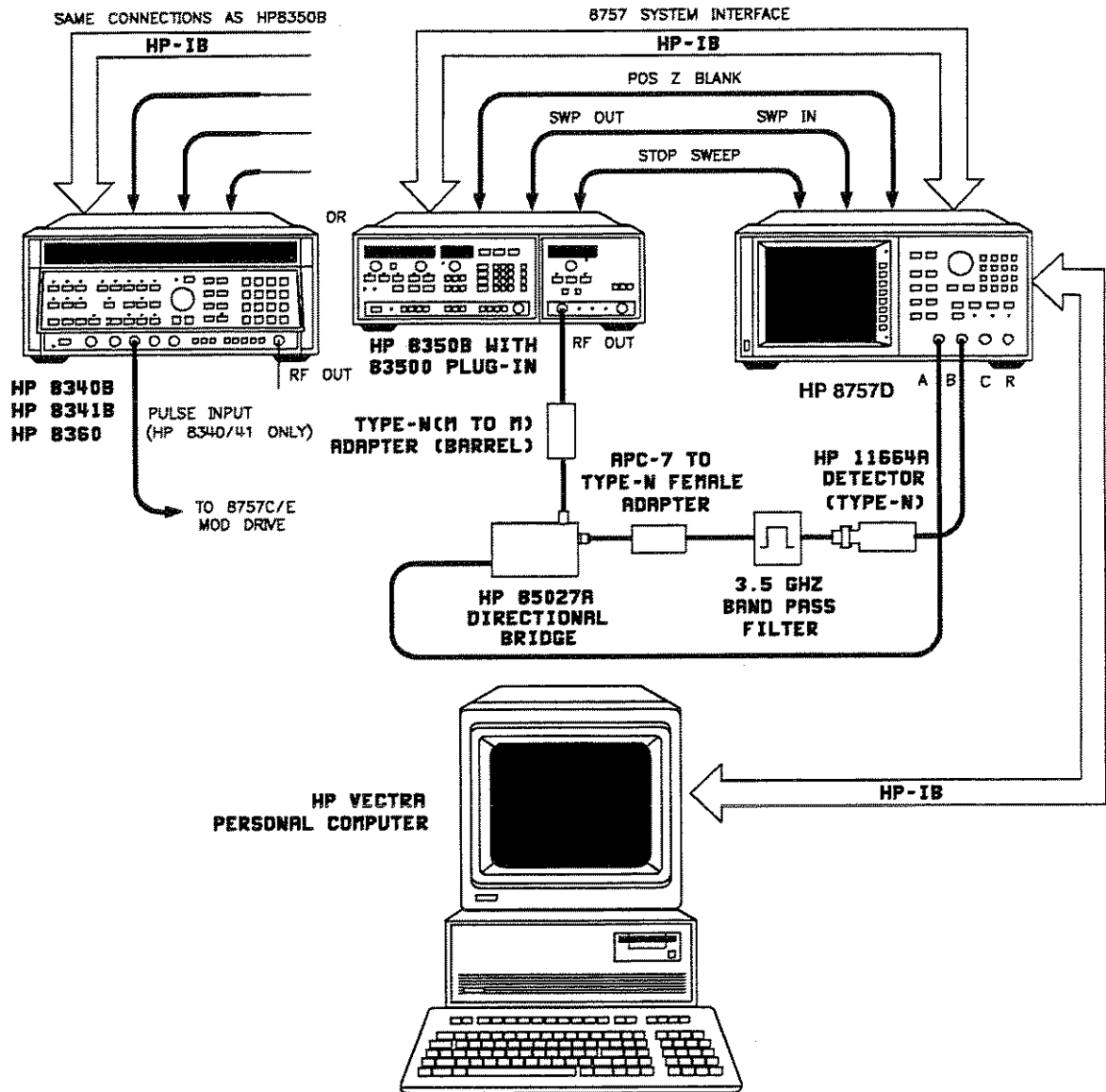

Figure 1. System Connections

Set-up

Connect the instruments as shown in Figure 1. The following procedure sets the HP-IB addresses of the instruments to operate properly with the programs contained in this guide. If the HP 82335A HP-IB interface card is not installed in the HP Vectra PC, follow the instructions in the *HP 82335A HP-IB Command Library Manual* for installation. Before installation, set the interface select code to 7.

1. Turn on the HP 8350B Sweeper. Press [SHIFT] [LCL]. The FREQUENCY/TIME display shows the current HP-IB address of the source. If it is not 19, press [1] [9] [GHz]. The HP 8340B or 8341B Synthesized Sweeper operates the same, although the address is displayed in the right-hand display area. For the HP 8360, access the HP-IB menu under the [SYSTEM MENU] key. Verify that the address is 19 and programming language is "Analyzer".

2. Power on the HP 8757D/E Scalar Network Analyzer. The current HP-IB address is shown in the active entry area of the CRT. If it is not 16, press [LOCAL] [8757] [1] [6] [ENT] to set the address to 16.

Check out procedure

Press [PRESET] on the analyzer. If the 8757 SYSTEM INTERFACE is properly connected, and the address of the source correctly set, both the analyzer and the source will perform an instrument preset. If either instrument detects a failure during instrument preset, that instrument displays the error encountered. The operating manual of the source gives instructions to help interpret the error message. If the analyzer displays an error message, see "In Case of Difficulty" in the operating manual.

Configuring Microsoft QuickC

It is important to configure Microsoft QuickC properly for operation with the HP 82335A HP-IB Command Library and the following programs. Before running any program, verify the following:

1. When installing Microsoft QuickC, choose either the small or large memory model. More importantly, the graphics library (GRAPHICS.LIB) should be included in the combined standard QuickC library (or libraries if you installed more than one memory model). If you did not do this upon initial installation, you may want to re-install Microsoft QuickC. Refer to the Microsoft QuickC manuals for more information.
2. It is assumed that Microsoft QuickC is installed in the "qc25" directory on the default drive with the following subdirectories:

qc25\bin	for binary and help files
qc25\include	for include files
qc25\lib	for library files

3. Copy the following HP 82335A HP-IB Command Library files to the proper destination:

```
CLHPIB.LIB --> qc25\lib\CLHPIB.LIB
CHPIB.H --> qc25\include\CHPIB.H
CFUNC.H --> qc25\include\CFUNC.H
```

4. Load Microsoft QuickC by typing "QC" at the MS-DOS prompt. You may need to change the default directory to "qc25".
5. Activate the Microsoft QuickC Options menu by clicking the mouse on the menu bar or by pressing the [ALT] [O] keys. Enable the "Full Menus" option.
6. Again from the Microsoft QuickC Options menu, select the "Environment" menu. Enter the appropriate file directory names using the names in step 2 above. Select <OK> when done.
7. Again from the Microsoft QuickC Options menu, select the "Make" menu. Select the "Linker Flags" option. From this menu, enter the following for "GLOBAL FLAGS: Stack Size":

```
4096
```

Also from this menu, enter the following for "CUSTOM FLAGS: Global":

```
qc25\lib\clhplib.lib
```

Select <OK> when done.

This will allow you to compile and run programs using HP 82335A HP-IB Command Library within the Microsoft QuickC integrated environment and avoid any run-time errors for stack overflow. The default stack size is 2048 bytes and run-time errors

will be encountered on programs that have large data arrays used for trace data and/or learn strings.

When you exit Microsoft QuickC, the information entered in steps 5, 6, and 7, will be retained in its startup information file (QC.INI) so that you will not need to be re-enter them later.

If you wish to use the command line compiler instead of compiling within the integrated environment, use QCL with the appropriate switches. For "filename.c", the following compiles the file using the large memory model:

```
qcl/AL filename.c/link\qc25\lib\clhplib.lib+
\qc25\lib\STACK:4096
```

The flags for the QuickC command line compiler (QCL) are case sensitive so be careful to enter them correctly.

Programming examples

The following example programs introduce the HP-IB capabilities of the analyzer. Each example program consists of these sections:

1. A description of the functions exercised.
2. The program listing.
3. An explanation of each program line.
4. Detailed instructions for operating the program.

When you finish all of the example programs, you will have a good idea of the power of the HP 8757D/E when used in an automatic system. Note that line numbers aren't used in C programs but are included in the program listings for the functional explanations. The HP-IB Command Library function names are shown in upper case for emphasis. Remember that identifier names are case-sensitive in the C language, so you must be consistent in your usage.

Error checking line should be performed after every HP-IB library call. Each HP 82335A HP-IB Command Library call returns a value representing the error status of the operation. An error handler routine (see program 1) can be used to return an appropriate HP-IB error message (timeout, etc.) if an error occurs. For example:

```
error = IOTIMEOUT (isc,10.0);
error_handler (error, "IOTIMEOUT");
```

If an error occurs, the number corresponding to that error is assigned to the variable "error". Within the error_handler routine, "error" is compared to the constant NOERR (=0). If an error occurred, a message appears on the computer screen stating the error number and type of error. The error values and errstr function are contained within the CHPIB.H include file.

Program 1: remote, local, and local lockout

The analyzer may be used with the front panel (local operation) or programmed via HP-IB (remote operation). The programmer has control over the operation of all instruments in the system.

When the computer first addresses an instrument, the instrument is placed in a special remote operating mode, called remote mode. When in remote, the instrument does not respond to its front panel, except for the [LOCAL] key. [LOCAL] cancels the remote mode and allows the instrument to be used with its front panel.

The computer can also return the instrument to local operation. To do so, the computer sends a special command that forces the instrument to go to local mode.

The programmer of an automatic system may need to prevent the operator from returning the instrument to local operation (via [LOCAL]). When the local lockout function of the computer is used, the instruments cannot exit remote mode, even if [LOCAL] is pressed.

Frequently, the programmer needs to place the instruments connected to the computer into a known state. When preset, the analyzer defaults to the conditions shown below. The instrument preset function operates the same as the front-panel [PRESET] key on the analyzer and the source. When presetting the analyzer and its associated source, send the PRESET command only to the analyzer. The analyzer will preset the source attached to the 8757 SYSTEM INTERFACE.

HP 8757D/E instrument preset conditions

Channels 1 and 2 on. The channel menu appears in the softkey area of the CRT.

- Measure power A on channel 1.
- Measure power B on channel 2.
- Measure power C² (or B¹) on channel 3.
- Measure power R on channel 4.
- Display measurement data in log magnitude format.
- Scale = 20 dB/div.
- Reference level 0 dB for all channels.
- Reference level step size = 20 dB.
- Averaging off.
- Averaging factor = 8.
- Cursor off.
- All labels on.
- Channel 1 as the active channel.
- Modulation drive on.
- Number of points = 401.
- Detector mode set for AC detection.
- Smoothing set for 5.0% of span (off).

- Cursor format = log magnitude.
- Search value = -3 dB¹.
- Adaptive normalization off¹.
- Temperature compensation on.
- Repeat autozero off.
- Detector amplitude offset reset to 0.¹
- Detector frequency offset³ off, start and stop = 50 MHz.

Source

- Instrument preset.
- Sweep time set to 200 ms.
- HP 8350B square wave modulation on
- HP 8340/41 SHIFT PULSE on; RF Output on.
- HP 8360 Scalar Modulation on; RF Output on; Analyzer mode.

Plotter

- Abort plot if in progress.
- P1 and P2 scaling points unchanged.
- Selection of plotter pens unchanged.

Printer

- Abort print if in progress.

Disk drive¹

- Abort any data transfers in progress.
- Unit number unchanged.
- Volume number unchanged.
- ASCII or binary mode unchanged.

The following analyzer conditions are not changed during a PRESET (IP) command execution:

- Reference position.
- Trace memory.
- Save/Recall registers.
- HP-IB addresses.
- Request mask.
- Limit lines¹.
- Title.
- Detector offset (HP 8757E only).
- User-defined plot.
- 8757 System Interface control on/off.
- Repeat autozero timer.
- Display intensity.
- Display colors¹.

1. HP 8757D only.
2. HP 8757D Option 001 only.
3. HP 8757D with HP 85037 series precision detector only.

Program 1 listing

```
10: /* HP 8757D/E QuickC IPG Program1 */
20:
30: #include <graph.h>
40: #include <stdio.h>
50: #include <cfunc.h>
60: #include <chplib.h>
70:
80: void disp_prompt (void);
90: void error_handler (int error_no, char
    *routine);
100:
110: main ()
120: {
130:     long     isc=7,
140:           sna=716;
150:     int      error;
170:     _clearscreen (_GCLEARSCREEN);
180:
190:     error = IOTIMEOUT (isc,10.0);
200:     error_handler (error, "IOTIMEOUT");
210:     error = IOABORT (isc);
220:     error_handler (error, "IOABORT");
230:     error = IOCLEAR (isc);
240:     error_handler (error, "IOCLEAR");
250:     error = IOREMOTE (sna);
260:     error_handler (error, "IOREMOTE");
270:     disp_prompt ();
280:
290:     error = IOREMOTE (sna);
300:     error_handler (error, "IOREMOTE");
310:     error = IOLLOCKOUT (isc);
320:     error_handler (error, "IOLLOCKOUT");
330:     disp_prompt ();
340:
350:     error = IOLOCAL (isc);
360:     error_handler (error, "IOLOCAL");
370:     disp_prompt ();
380:
390:     error = IOOUTPUTS (sna, "IP",2);
400:     error_handler (error, "IOOUTPUTS");
410: }
420:
430: void disp_prompt (void)
440: {
450:     char ch;
460:
470:     _settextposition (25,1);
480:     printf ("Press <ENTER> to continue
        \n");
490:     ch = getche ();
500:     _clearscreen (_GCLEARSCREEN);
510: }
520:
530: void error_handler (int error_no, char
    *routine)
540: {
550:     char ch;
560:
570:     if (error_no != NOERR)
580:     {
590:         printf ("Error in call to %s \n",
            routine);
600:         printf ("      Error = %d : %s \n",
            error_no, errstr (error_no));
610:         printf ("Press <ENTER> to contin
            ue\n");
620:         ch = getche ();
630:         exit (1);
640:     }
650: }
```

Program 1 explanation

- Line 30 Tell the compiler which file includes information on `_clearscreen()` and `_settextposition()`.
- Line 40 Tell the compiler which file includes information on `printf()`.

- Line 50 Tell the compiler which file includes information on the HP 82335A HP-IB Command Library I/O functions.
- Line 60 Tell the compiler which file includes information on the HP 82335A HP-IB Command Library error constants and `errstr()`.
- Line 80 Function prototype for the `disp_prompt()` routine.
- Line 90 Function prototype for the `error_handler()` routine.
- Line 110 Define the beginning of the `main()` routine.
- Line 130 Define a variable and assign it a value for the interface select code of the HP 82335A HP-IB interface card.
- Line 140 Define a variable and assign it a value for the HP-IB address of the HP 8757D/E analyzer.
- Line 150 Define a variable for the HP-IB Command Library error status.
- Line 170 Clear the computer CRT.
- Line 190 Define a system timeout of 10 seconds. Timeout allows recovery from I/O operations that aren't completed in less than 10 seconds. The timeout value passed must be a float, so include the decimal point (vs. passing just "10") so it is not passed as an integer.
- Line 200 Perform error trapping.
- Line 210 Abort any HP-IB transfers.
- Line 220 Perform error trapping.
- Line 230 Clear the analyzer's HP-IB interface.
- Line 240 Perform error trapping.
- Line 250 Set the analyzer and source to remote mode.
- Line 260 Perform error trapping.
- Line 270 Wait until [ENTER] is pressed to continue.
- Line 290 Set the analyzer and source to remote mode.
- Line 300 Perform error trapping.
- Line 310 Lock out the [LOCAL] key of the analyzer and source.
- Line 320 Perform error trapping.
- Line 330 Wait until [ENTER] is pressed to continue.
- Line 350 Set the analyzer and source to local mode.

Line 360 Perform error trapping.

Line 370 Wait until [ENTER] is pressed to continue.

Line 390 Preset the analyzer and source.

Line 400 Perform error trapping.

Line 410 The end of main().

Line 430 Define a routine that prints a prompt on the computer CRT and waits for [ENTER] to be pressed.

Line 450 Define a variable to hold the keypress.

Line 470 Locate the text cursor at the beginning of row 25.

Line 480 Print a prompt on the computer CRT.

Line 490 Wait for a keypress, then continue.

Line 500 Clear the computer CRT.

Line 510 The end of disp_prompt().

Line 530 Define a routine that checks the HP-IB Command Library error status. Define the types of variables passed to this routine: error_no is the error value, routine is the HP-IB Command Library routine called.

Line 550 Define a variable to hold the keypress.

Line 570 Test if an error actually occurred.

Line 590 Yes, one did. Print on the computer CRT which HP-IB Command Library routine the error occurred in.

Line 600 Print on the computer CRT the error number and a message.

Line 610 Print a prompt on the computer CRT.

Line 620 Wait for a keypress, then continue.

Line 630 Since an error occurred, halt program execution. If you want to trap for specific errors, this "exit" statement could be replaced with some specific error messages to display, error correcting actions to be performed, and then allow program execution to continue.

Line 650 The end of error_handler().

Running program 1

1. Press [ALT] [F] [N] on the computer. This clears the QuickC screen.
2. Type in the program.
3. Press [ALT] [R] [G] on the computer to run the program.
4. When the program pauses, the analyzer is in remote mode. You can verify this by observing the lights in the INSTRUMENT STATE area of the analyzer. The R (remote) and L (listen) lights should be on. Try pressing any key on the analyzer (except [LOCAL]). Nothing happens. The source is also in remote mode. Now press [LOCAL] and verify that the keys on the analyzer are active. Also, notice the R light went out when you pressed [LOCAL]. The source went into local mode along with the analyzer.
5. Press [ENTER] on the computer. The analyzer is again in remote mode. This time, however, the [LOCAL] key is locked out. Try pressing [LOCAL] and the other keys. None of the keys on the analyzer or the source cause any action.
6. Press [ENTER] on the computer. All instruments on the HP-IB interface are returned to local mode, including the analyzer and source. Verify that the R light on the analyzer and the REM light on the source are off.
7. Press [ENTER] on the computer. The analyzer and source are both preset. Note that the computer sent the Instrument Preset command only to the analyzer. The analyzer, in turn, presets the source.

Remember, to preset both the analyzer and the source, you only need to send the instrument preset command to the analyzer. Do not send instrument preset to the source by way of passthru mode (discussed in program 3).

Program 2: controlling the front panel

All front panel keys and most of the softkeys of the analyzer may be programmed remotely via HP-IB. For example, you can program the scale per division, reference level, and reference position for each channel.

Program 2 listing

```
10: /* HP8757D/E QuickC IPG Program2 */
20:
30: #include <string.h>
40: #include <graph.h>
50: #include <stdio.h>
60: #include <cfunc.h>
70: #include <chpib.h>
80:
90: int IOOUTPUTS_CHK (long hpib_adr, char
    *cmd_str);
100: void disp_prompt (void);
110: void error_handler (int error_no, char
    *routine);
120:
130: main ()
140: {
150:     long    isc =7,
160:           sna =716;
170:     int     error;
180:
190:     _clearscreen (_GCLEARSCREEN);
200:
210:     error = IOTIMEOUT (isc,10.0);
220:     error_handler (error, "IOTIMEOUT");
230:     error = IOABORT (isc);
240:     error_handler (error, "IOABORT");
250:     error = IOCLEAR (isc);
260:     error_handler (error, "IOCLEAR");
270:     error = IOOUTPUTS_CHK (sna, "IP");
280:     disp_prompt ();
290:
300:     error = IOOUTPUTS_CHK (sna, "C1C0C2");
310:     disp_prompt ();
320:
330:     error = IOOUTPUTS_CHK (sna, "SD10");
340:     disp_prompt ();
350:
360:     error = IOOUTPUTS_CHK (sna, "RL-10");
370:     disp_prompt ();
380:
390:     error = IOOUTPUTS_CHK (sna, "RP4");
400:     disp_prompt ();
410:
420:     error = IOOUTPUTS_CHK (sna, "IA");
430:     disp_prompt ();
440:
450:     error=IOOUTPUTS_CHK(sna,"C0C1SD5;RP4;RL-5");
460: }
470:
480: int IOOUTPUTS_CHK (long hpib_adr, char
    *cmd_str)
490: {
500:     int    length, error_no;
510:
520:     length = strlen (cmd_str);
530:     error_no = IOOUTPUTS (hpib_adr, cmd_str,
    length);
540:     error_handler (error_no,"IOOUTPUTS_CHK");
550:     return error_no;
560: }
570:
580: void disp_prompt (void)
590: {
600:     char ch;
610:
620:     _settextposition (25,1);
630:     printf ("Press <ENTER> to continue\n");
640:     ch = getche ();
650:     _clearscreen (_GCLEARSCREEN);
660: }
670:
680: void error_handler (int error_no, char
    *routine)
690: {
700:     char ch;
710:
720:     if (error_no != NOERR)
730:     {
740:         printf ("Error in call to %s \n",
    routine);
750:         printf (" Error = %d : %s \n",
    error_no,errstr (error_no));
760:         printf ("Press <ENTER> to continue\n");
770:         ch = getche ();
780:         exit (1);
790:     }
800: }
```

Program 2 explanation

- Line 30 Tell the compiler which file includes information on string functions.
- Line 40 Tell the compiler which file includes information on `_clearscreen()` and `_settextposition()`.
- Line 50 Tell the compiler which file includes information on `printf()`.
- Line 60 Tell the compiler which file includes information on the HP-IB Command Library I/O functions.
- Line 70 Tell the compiler which file includes information on the HP-IB Command Library error constants and `errstr()`.
- Line 90 Function prototype for the `IOOUTPUTS_CHK()` routine.
- Line 100 Function prototype for the `disp_prompt()` routine.
- Line 110 Function prototype for the `error_handler()` routine.
- Line 130 Define the beginning of the `main()` routine.
- Line 150 Define a variable and assign it a value for the interface select code.
- Line 160 Define a variable and assign it a value for the HP-IB address of the analyzer.
- Line 170 Define a variable for the HP-IB Command Library error status.
- Line 190 Clear the computer CRT.
- Line 210 Define a system timeout of 10 seconds.
- Line 220 Perform error trapping.
- Line 230 Abort any HP-IB transfers.
- Line 240 Perform error trapping.
- Line 250 Clear the analyzer's HP-IB interface.
- Line 260 Perform error trapping.
- Line 270 Preset the analyzer and the source.
- Line 280 Wait until [ENTER] is pressed to continue.
- Line 300 Select channel 1 and turn it off. Turn on channel 2.
- Line 310 Wait until [ENTER] is pressed to continue.
- Line 330 Set the scale per division to 10 dB. Note that semicolon ("`;`") terminators are needed after any analyzer command that can have a variable length. However, no terminator is needed here because this is the only command on the line and the linefeed in the End-of-Line string (the HP 82335A default is carriage return/linefeed) will terminate it.

- Line 340 Wait until [ENTER] is pressed to continue.
- Line 360 Set the reference level to -10 dBm. Again, note the absence of a terminator (";").
- Line 370 Wait until [ENTER] is pressed to continue.
- Line 390 Set the reference position line to the center of the screen (graticule 4).
- Line 400 Wait until [ENTER] is pressed to continue.
- Line 420 Program channel 2 to measure input A (reflection) instead of input B (transmission).
- Line 430 Wait until [ENTER] is pressed to continue.
- Line 450 There are many commands on one line, with terminators. Turn channel 2 off and channel 1 on (COC1). Set the scale per division (SD) to 5 dB, the reference position line (RP) to the center of the screen, and the reference level (RL) to -5 dBm. Semicolon (";") terminators are needed after any analyzer command that can have a variable length. Extra terminators never hurt, so use them liberally.
- Line 460 The end of main().
- Line 480 Define a routine that outputs string commands and performs error trapping. Define the types of variables passed to this routine: hpib_adr is the HP-IB address, cmd_str is the command string to output.
- Line 500 Define variables for the length of the string and the error status.
- Line 520 Determine the length of the command string.
- Line 530 Output the command string.
- Line 540 Perform error trapping.
- Line 550 Return the error status as the value of the routine.
- Line 560 The end of IOOUTPUTS_CHK().
- Line 580 Define a routine that prints a prompt on the computer CRT and waits for [ENTER] to be pressed.
- Line 600 Define a variable to hold the keypress.
- Line 620 Locate the text cursor at the beginning of row 25.
- Line 630 Print a prompt on the computer CRT.
- Line 640 Wait for a keypress, then continue.
- Line 650 Clear the computer CRT.
- Line 660 The end of disp_prompt().
- Line 680 Define a routine that checks the HP-IB Command Library error status. Define the types of variables passed to this routine: error_no is the error value, routine is the HP-IB Command Library routine called.
- Line 700 Define a variable to hold the keypress.
- Line 720 Test if an error actually occurred.
- Line 740 Yes, one did. Print on the computer CRT which HP-IB Command Library routine the error occurred in.
- Line 750 Print on the computer CRT the error number and a message.
- Line 760 Print a prompt on the computer CRT.
- Line 770 Wait for a keypress, then continue.
- Line 780 Since an error occurred, halt program execution.
- Line 800 The end of error_handler().

Running program 2

1. Press [ALT] [F] [N] on the computer. This clears the previous program.
2. Type in this program and press [ALT] [R] [G] on the computer.
3. The computer presets the analyzer and source and pauses. Note the settings of channel 1 and 2, then press [ENTER].
4. Channel 1 is turned off. Channel 2 is now the active channel, as you can see from the highlighted box around the channel 2 mode labels on the analyzer CRT. Press [ENTER].
5. Channel 2 scale per division is now set to 10 dB. It defaulted to 20 dB/div at preset. Press [ENTER].
6. The reference level is set to -10 dBm (it was 0.0 dBm). Press [ENTER].
7. The reference position line is set to the center of the CRT (graticule 4). The top of the CRT is graticule 8 and the bottom is graticule 0. Press [ENTER].
8. Change the measurement to input A (reflection) instead of input B (transmission). At preset, channel 2 defaults to input B. Press [ENTER].
9. In one statement: turn off channel 2, turn on channel 1, set the scale per division to 5 dB, set the reference position line to the center of the CRT, and set the reference level to -5 dBm.

Program 3: passthru mode

In normal operation, the system source, digital plotter, printer, and disk drive (HP 8757D only) are connected to the 8757 SYSTEM INTERFACE. This connection allows the analyzer to control and extract information from the other parts of the measurement system. To control other instruments with the computer, the analyzer has a built-in passthru command that takes a command from the computer and passes it on to one of the instruments connected to the 8757 SYSTEM INTERFACE.

To initiate passthru mode, first tell the analyzer which instrument you wish to command by setting the passthru address. Then, to talk (or listen) to that device, address the analyzer's special passthru HP-IB address (which is different from the analyzer's HP-IB address). While in the passthru mode, the analyzer stops updating its CRT and does not respond to its front panel (because it's in remote mode). To remove the analyzer from passthru mode, simply address it via HP-IB. While in passthru mode, do not press [LOCAL] on the analyzer.

The analyzer's passthru address is calculated from its HP-IB address. If the address of the analyzer is even (such as 16 decimal) then the passthru address is the next larger number (17 decimal). If the address of the analyzer is odd (such as 15 decimal), then the passthru address is the next smaller number (14 decimal). Never set the address of the analyzer such that its address conflicts with one of the instruments connected to the 8757 SYSTEM INTERFACE. For instance, if the source is set to 19 decimal, do not set the address of the analyzer to 19.

Data can be sent to or received from any instrument on the 8757 SYSTEM INTERFACE via passthru mode. The IOLOCAL, IOREMOTE, and IOTRIGGER HP-IB messages do not pass through the analyzer.

Program 3 listing

```
10: /* HP8757D/E QuickC IPG Program3 */
20:
30: #include <string.h>
40: #include <graph.h>
50: #include <stdio.h>
60: #include <cfunc.h>
70: #include <chpib.h>
80:
90: int IOOUTPUTS_CHK (long hpib_adr, char
    *cmd_str);
100: void error_handler (int error_no, char
    *routine);
110:
120: main ()
130: {
140:     char    cmd [80];
150:     long    isc =7,
160:           sna=716,
170:           passthru=717;
180:     int     error;
190:     float   min_freq, max_freq,
200:           start_freq, stop_freq;
210:     _clearscreen (_GCLEARSCREEN);
220:
230:     error = IOTIMEOUT (isc,10.0);
240:
```

```
250:     error_handler (error, "IOTIMEOUT");
260:     error = IOABORT (isc);
270:     error_handler (error, "IOABORT");
280:     error = IOCLEAR (isc);
290:     error_handler (error, "IOCLEAR");
300:
310:     error = IOOUTPUTS_CHK (sna, "IP");
320:     error = IOOUTPUTS_CHK (sna, "PT19");
330:     error = IOOUTPUTS_CHK (passthru, "OPFA");
340:     error = IOENTER (passthru, &min_freq);
350:     error_handler (error, "IOENTER");
360:     min_freq = min_freq /1.0e+9;
370:     error = IOOUTPUTS_CHK (passthru, "OPFB");
380:     error = IOENTER (passthru, &max_freq);
390:     error_handler (error, "IOENTER");
400:     max_freq = max_freq /1.0e+9;
410:     error = IOCLEAR (sna);
420:     error_handler (error, "IOCLEAR");
430:     printf ("Frequency limits: %f to %f
    GHz\n", min_freq, max_freq);
440:
450:     printf ("Start frequency (GHz) ? ");
460:     scanf ("%f", &start_freq);
470:     printf ("Stop frequency (GHz) ? ");
480:     scanf ("%f", &stop_freq);
490:
500:     sprintf (cmd, "FA%fgZ;FB%fGZ;",
    start_freq, stop_freq);
510:     error = IOOUTPUTS_CHK (passthru, cmd);
520:     error = IOCLEAR (sna);
530:     error_handler (error, "IOCLEAR");
540: }
550:
560: int IOOUTPUTS_CHK (long hpib_adr, char
    *cmd_str)
570: {
580:     int    length, error_no;
590:
600:     length = strlen (cmd_str);
610:     error_no = IOOUTPUTS (hpib_adr,
    cmd_str, length);
620:     error_handler (error_no, "IOOUTPUTS_CHK");
630:     return error_no;
640: }
650:
660: void error_handler (int error_no, char
    *routine)
670: {
680:     char    ch;
690:
700:     if (error_no != NOERR)
710:     {
720:         printf ("Error in call to %s \n",
    routine);
730:         printf ("      Error = %d : %s \n",
    error_no, errstr (error_no));
740:         printf ("Press <ENTER> to continue
    \n");
750:         ch = getche ();
760:         exit (1);
770:     }
780: }
```

Program 3 explanation

- Line 30 Tell the compiler which file includes information on string functions.
- Line 40 Tell the compiler which file includes information on `_clearscreen()` and `_settextposition()`.
- Line 50 Tell the compiler which file includes information on `printf()`.
- Line 60 Tell the compiler which file includes information on the HP-IB Command Library I/O functions.
- Line 70 Tell the compiler which file includes information on the HP-IB Command Library error constants and `errstr()`.

Line 90	Function prototype for the IOOUTPUTS_CHK() routine.	Line 370	Command the source to output its current stop frequency.
Line 100	Function prototype for the error_handler() routine.	Line 380	Read the stop frequency from the source.
Line 120	Define the beginning of the main() routine.	Line 390	Perform error trapping.
Line 140	Define a string variable for the output commands.	Line 400	Scale the stop frequency to display it in GHz.
Line 150	Define a variable and assign it a value for the interface select code.	Line 410	Exit passthru mode by clearing the analyzer's HP-IB interface.
Line 160	Define a variable and assign it a value for the HP-IB address of the analyzer. (This is the analyzer's control address).	Line 420	Perform error trapping.
Line 170	Define a variable and assign it a value for the analyzer's passthru address. By communicating to this HP-IB address, the computer will control a device connected to the 8757 SYSTEM INTERFACE.	Line 430	Print the start and stop frequencies.
Line 180	Define a variable for the HP-IB Command Library error status.	Line 450	Print a prompt asking for the start frequency.
Line 190	Define variables for the minimum and maximum frequencies of the source.	Line 460	Get start frequency from user.
Line 200	Define variables for the start and stop frequencies of a sweep.	Line 470	Print a prompt asking for the stop frequency.
Line 220	Clear the computer CRT.	Line 480	Get stop frequency from user.
Line 240	Define a system timeout of 10 seconds.	Line 500	Create a formatted output by printing the start and stop frequencies of the source to a string.
Line 250	Perform error trapping.	Line 510	Set the start and stop frequencies of the source to those given by the user.
Line 260	Abort any HP-IB transfers.	Line 520	Exit passthru mode by clearing the analyzer's HP-IB interface.
Line 270	Perform error trapping.	Line 530	Perform error trapping.
Line 280	Clear the analyzer's HP-IB interface.	Line 540	The end of main().
Line 290	Perform error trapping.	Line 560	Define a routine that outputs string commands and performs error trapping. Define the types of variables passed to this routine: hpib_adr is the HP-IB address, cmd_str is the command string to output.
Line 310	Preset the analyzer and source.	Line 580	Define variables for the length of the string and the error status.
Line 320	Tell the analyzer which device is controlled through the analyzer's passthru address. In this case, the source (device19).	Line 600	Determine the length of the command string.
Line 330	Send a command to the source. Command it to output its current start frequency.	Line 610	Output the command string.
Line 340	Read the start frequency from the source.	Line 620	Perform error trapping.
Line 350	Perform error trapping.	Line 630	Return the error status as the value of the routine.
Line 360	Scale the start frequency to display it in GHz.	Line 640	The end of IOOUTPUTS_CHK().
		Line 660	Define a routine that checks the HP-IB Command Library error status. Define the types of variables passed to this routine: error_no is the error value, routine is the HP-IB Command Library routine called.

Line 680 Define a variable to hold the keypress.

Line 700 Test if an error actually occurred.

Line 720 Yes, one did. Print on the computer CRT which HP-IB Command Library routine the error occurred in.

Line 730 Print on the computer CRT the error number and a message.

Line 740 Print a prompt on the computer CRT.

Line 750 Wait for a keypress, then continue.

Line 760 Since an error occurred, halt program execution.

Line 780 The end of error_handler().

Running program 3

1. Clear the computer CRT and type in the program.
2. Press [ALT] [R] [G] on the computer to run the program.
3. The computer presets the analyzer and the source, reads the start and stop frequency of the source, and displays it on the CRT of the computer. At preset, the source defaults to the full frequency range of the plug-in. The values read represent the frequency limits of this plug-in. When the computer stops, it displays the prompt:

Start frequency (GHz)?

Enter a start frequency in the frequency range of the plug-in and press [ENTER].
4. The computer displays the prompt:

Stop frequency (GHz)?

Enter a stop frequency in the frequency range of the plug-in (but higher than the start frequency) and press [ENTER].
5. The computer sets the start and stop frequency of the source to those you entered. The analyzer immediately begins sweeping the frequency range you defined.

Points to remember: You must address the analyzer after using passthru mode to return it to normal swept operation. Any command can be sent via passthru mode to any instrument on the 8757 SYSTEM INTERFACE, and any data can be read. Service requests and parallel polls do not passthru the analyzer.

Program 4: cursor operations

To enhance the speed and accuracy of measurements, the analyzer contains a built-in cursor that displays the frequency and magnitude of a trace at any given point. To make measurements even more efficient, the cursor may be set to the maximum or minimum point on the trace simply by pressing a softkey. These cursor functions are available via HP-IB commands.

With a computer, the cursor may be turned on and off, its position (0 to n-1, where n is the number of points per trace) set, its value and position read, and set to the maximum or minimum point on the trace. The cursor functions all apply to the active channel (the channel accessed most recently). You have complete control over cursor operations via HP-IB.

Cursor programming is especially useful for measuring parameters like flatness and maximum power, where you are interested in the highest and lowest point on the trace. For measuring parameters such as 3 dB points and other specific points (not a maximum or minimum), it is more efficient to use either the cursor search functions (available on the HP 8757D only) or to read the entire trace and search for the points you need.

Program 4 listing

```

10: /* HP 8757D/E QuickC IPG Program 4 */
20:
30: #include <string.h>
40: #include <graph.h>
50: #include <stdio.h>
60: #include <cfunc.h>
70: #include <chpib.h>
80:
90: int IOOUTPUTS_CHK (long hpib_adr, char
    *cmd_str);
100: void error_handler (int error_no, char
    *routine);
110:
120: main ()
130: {
140:     char    cmd [80];
150:     long    isc = 7,
160:           sna = 716,
170:           passthru = 717;
180:     int     error, elements,
190:           crsr_posn, new_posn;
200:     float   start_freq = 2.0,
210:           stop_freq = 5.0,
220:           crsr_freq, cur_freq, crsr_vals[2];
230:
240:         _clearscreen (_GCLEARSCREEN);
250:
260:     error = IOTIMEOUT (isc,10.0);
270:     error_handler (error, "IOTIMEOUT");
280:     error = IOABORT (isc);
290:     error_handler (error, "IOABORT");
300:     error = IOCLEAR (isc);
310:     error_handler (error, "IOCLEAR");
320:
330:     error = IOOUTPUTS_CHK (sna, "IP");
340:     error = IOOUTPUTS_CHK (sna, "PT19");
350:     sprintf (cmd, "FA%fgZ;FB%fgZ;",
        start_freq, stop_freq);
360:     error = IOOUTPUTS_CHK (passthru, cmd);
370:
375:     error = IOOUTPUTS_CHK(sna," ");
380:     error = IOOUTPUTS_CHK (sna, "C2CXOC");
390:     elements = 2;
400:     error = IOENTERA (sna, crsr_vals, &ele
        ments);
410:     error_handler (error, "IOENTERA");

```



```

420:     printf ("Cursor reads %f dB at
         position %4.0f\n\n", crsr_vals[0],
         crsr_vals[1]);
430:
440:     printf ("Desired cursor position
         (0..400) ? ");
450:     scanf ("%i", &new_posn);
460:     sprintf (cmd, "SC%d;", new_posn);
470:     error = IOOUTPUTS_CHK (sna, cmd);
480:     error = IOOUTPUTS_CHK (sna, "OC");
490:     elements = 2;
500:     error = IOENTERA (sna, crsr_vals, &ele
         ments);
510:     error_handler (error, "IOENTERA");
520:     printf ("Value at position %4.0f is
         %7.3f dB\n\n", crsr_vals[1],
         crsr_vals[0]);

530:
540:     printf ("Cursor frequency (GHz) ? ");
550:     scanf ("%f", &cur_freq);
560:     new_posn = 400 * ((cur_freq -
         start_freq)/(stop_freq - start_freq));
570:     sprintf (cmd, "SC%d;", new_posn);
580:     error = IOOUTPUTS_CHK (sna, cmd);
590:     error = IOOUTPUTS_CHK (sna, "OC");
600:     elements = 2;
610:     error = IOENTERA (sna, crsr_vals, &ele
         ments);
620:     error_handler (error, "IOENTERA");
630:     cur_freq = start_freq + (stop_freq -
         start_freq) * (crsr_vals[1]/ 400);
640:     printf ("Cursor reads %7.3f dB at
         %7.3f GHz\n", crsr_vals[0], cur_freq);
650: }
660:
670: int IOOUTPUTS_CHK (long hpib_adr, char
         *cmd_str)
680: {
690:     int    length, error_no;
700:
710:     length = strlen (cmd_str);
720:     error_no = IOOUTPUTS (hpib_adr,
         cmd_str, length);
730:     error_handler (error_no,
         "IOOUTPUTS_CHK");
740:     return error_no;
750: }
760:
770: void error_handler (int error_no, char
         *routine)
780: {
790:     char  ch;
800:
810:     if (error_no != NOERR)
820:     {
830:         printf ("Error in call to %s \n",
         routine);
840:         printf ("      Error = %d : %s
         \n", error_no, errstr (error_no));
850:         printf ("Press <ENTER> to continue
         \n");
860:         ch = getche ();
870:         exit (1);
880:     }
890: }

```

Line 70 Tell the compiler which file includes information on the HP-IB Command Library error constants and errstr().

Line 90 Function prototype for the IOOUTPUTS_CHK() routine.

Line 100 Function prototype for the error_handler() routine.

Line 120 Define the beginning of the main() routine.

Line 140 Define a string variable for the output commands.

Line 150 Define a variable and assign it a value for the interface select code.

Line 160 Define a variable and assign it a value for the HP-IB address of the analyzer.

Line 170 Define a variable and assign it a value for the analyzer's passthru address.

Line 180 Define variables for the HP-IB Command Library error status and the number of elements to be read into an array.

Line 220 Define variables for the present and new cursor positions.

Line 200 Define a variable and assign it a value (in GHz) for the start frequency of the desired sweep.

Line 210 Define a variable and assign it a value (in GHz) for the stop frequency of the desired sweep.

Line 220 Define variables for the present and new cursor frequencies, and an array variable for reading the cursor values.

Line 240 Clear the computer CRT.

Line 260 Define a system timeout of 10 seconds.

Line 270 Perform error trapping.

Line 280 Abort any HP-IB transfers.

Line 290 Perform error trapping.

Line 300 Clear the analyzer's HP-IB interface.

Line 310 Perform error trapping.

Line 330 Preset the analyzer and source. This sets the number of points per trace to 401.

Line 340 Tell the analyzer which instrument is controlled through the passthru address (19 is the source).

Program 4 explanation

Line 30 Tell the compiler which file includes information on string functions.

Line 40 Tell the compiler which file includes information on _clearscreen() and _settextposition().

Line 50 Tell the compiler which file includes information on printf().

Line 60 Tell the compiler which file includes information on the HP-IB Command Library I/O functions.

Line 270 Perform error trapping.

Line 280 Abort any HP-IB transfers.

Line 290 Perform error trapping.

Line 300 Clear the analyzer's HP-IB interface.

Line 310 Perform error trapping.

Line 330 Preset the analyzer and source. This sets the number of points per trace to 401.

Line 340 Tell the analyzer which instrument is controlled through the passthru address (19 is the source).

- Line 350 Create a formatted output by printing the start and stop frequencies of the source to a string.
- Line 360 Command the source to set a start frequency of 2 GHz and a stop frequency of 5 GHz.
- Line 380 Set the cursor to the maximum point on channel 2 and command the analyzer to output the cursor's value and position.
- Line 375 Exit passthru mode. Allow analyzer to display update.
- Line 390 Define the number of elements to be read into an array.
- Line 400 Read the value and position of the cursor.
- Line 410 Perform error trapping.
- Line 420 Print the value and position of the cursor on the computer CRT.
- Line 440 Print a prompt asking for the cursor position.
- Line 450 Get new cursor position from the user. Input should be between 0 and 400.
- Line 460 Create a formatted output by printing the cursor position to a string.
- Line 470 Set the cursor to the new cursor position chosen by the user.
- Line 480 Command the analyzer to output the cursor's value and position.
- Line 490 Define the number of elements to be read into an array.
- Line 500 Read the value and position of the cursor at its new position.
- Line 510 Perform error trapping.
- Line 520 Print the cursor's value and position on the computer CRT.
- Line 540 Print a prompt asking for the cursor frequency.
- Line 550 Get new cursor frequency from the user. It must be within the frequency range of the sweep selected.
- Line 560 Calculate the position of the cursor from its frequency and the start and stop frequencies of the current measurement.
- Line 570 Create a formatted output by printing the cursor position to a string.
- Line 580 Set the cursor to the desired position.
- Line 590 Command the analyzer to output the cursor's value and position.
- Line 600 Define the number of elements to be read into an array.
- Line 610 Read the cursor's value and position.
- Line 620 Perform error trapping.
- Line 630 Calculate the cursor's actual frequency from its position and the start and stop frequencies of the current measurement. You can easily program other start and stop frequencies by following the example in program 3.
- Line 640 On the computer CRT, print the value and actual frequency of the cursor.
- Line 650 The end of main().
- Line 670 Define a routine that outputs string commands and performs error trapping. Define the types of variables passed to this routine: `hpib_adr` is the HP-IB address, `cmd_str` is the command string to output.
- Line 690 Define variables for the length of the string and the error status.
- Line 710 Determine the length of the command string.
- Line 720 Output the command string.
- Line 730 Perform error trapping.
- Line 740 Return the error status as the value of the routine.
- Line 750 The end of `IOOUTPUTS_CHK()`.
- Line 770 Define a routine that checks the HP-IB Command Library error status. Define the types of variables passed to this routine: `error_no` is the error value, `routine` is the HP-IB Command Library routine called.
- Line 790 Define a variable to hold the keypress.
- Line 810 Test if an error actually occurred.
- Line 830 Yes, one did. Print on the computer CRT which HP-IB Command Library routine the error occurred in.
- Line 840 Print on the computer CRT the error number and a message.
- Line 850 Print a prompt on the computer CRT.
- Line 860 Wait for a keypress, then continue.
- Line 870 Since an error occurred, halt program execution.
- Line 890 The end of `error_handler()`.

Running program 4

1. Clear the computer CRT and type in the program.
2. Press [ALT] [R] [G] on the computer.
3. The computer turns on both channels and sets channel 1 to reflection (input A) and channel 2 to transmission (input B). The cursor is positioned to the maximum point on the channel 2 trace and its value and position are read and displayed. At preset, the number of points per trace is 401.
4. The computer displays the prompt:

Desired cursor position (0..400)?

Type in a number between 0 and 400 and press [ENTER]. A position of 0 represents the left side of the analyzer's CRT (lowest frequency) and 400 represents the right side of the CRT (highest frequency). The position is set, and the cursor's value is read and printed on the CRT of the computer.

5. The computer displays the prompt:

Cursor frequency (GHz)?

Enter a frequency within the current start and stop frequencies of the measurement (0.01 to 20 GHz). The nearest cursor position is calculated and set. The value and position of the cursor are read, and the actual cursor frequency is calculated from the cursor's position.

Note: The original desired frequency and the actual cursor frequency are usually different. Because there are only 401 possible cursor positions, some frequencies cannot be set exactly.

To use more points per trace when using the HP 8757D, modify line 330 to be "IP SP801" for 801 points. Then modify the "400" in lines 440, 560, and 630, to "800".

Program 5: read a single value

Measurements often require that a single value be read at a CW frequency, particularly when extremely good frequency accuracy and resolution are required.

The analyzer is able to read and send a single reading of any measurement channel, via HP-IB, to the computer. The OUTPUT VALUE (OV) command operates on the active channel and causes the analyzer to send one reading of measurement data. Even when the analyzer is in normalized mode (MEAS-MEM), the OV command sends the measured, not the normalized, data.

Program 5 listing

```
10: /* HP8757D/E QuickC IPG Program5 */
20:
30: #include <string.h>
40: #include <graph.h>
50: #include <stdio.h>
60: #include <cfunc.h>
70: #include <chplib.h>
80:
90: int IOOUTPUTS_CHK (long hpib_adr, char
    *cmd_str);
100: void error_handler (int error_no, char
    *routine);
110:
120: main ()
130: {
140:     char    cmd [80];
150:     long    isc =7,
160:           sna =716,
170:           passthru =717;
180:     int     error, i;
190:     float   freq, freq_step, value;
200:
210:     _clearscreen (_GCLEARSCREEN);
220:
230:     error = IOTIMEOUT (isc,10.0);
240:     error_handler (error, "IOTIMEOUT");
250:     error = IOABORT (isc);
260:     error_handler (error, "IOABORT");
270:     error = IOCLEAR (isc);
280:     error_handler (error, "IOCLEAR");
290:
300:     error = IOOUTPUTS_CHK (sna, "IP");
310:     error = IOOUTPUTS_CHK (sna, "PT19");
320:     error = IOOUTPUTS_CHK (sna, "SW0");
330:
340:     freq =2.0;
350:     freq_step = 0.1;
360:     sprintf (cmd, "CW%fGZ;SF%fGZ;", freq,
    freq_step);
370:     error = IOOUTPUTS_CHK (passthru, cmd);
380:     error = IOOUTPUTS_CHK (sna, "C1IA");
390:
400:     for (i =1; i <=21; i = i +1)
410:     {
420:         error = IOOUTPUTS_CHK (sna, "OV");
430:         error = IOENTER (sna, &value);
440:         error_handler (error, "IOENTER");
450:         printf ("%4d: %8.3f dB at Freq %7.3f
    GHz\n", i, value, freq);
460:         error = IOOUTPUTS_CHK (passthru,
    freq = freq + freq_step;
480:     }
490:
500:     error = IOOUTPUTS_CHK (passthru,
    "FA2GZFB4GZ");
510:     error = IOOUTPUTS_CHK (sna, "SW1");
520: }
530:
540: int IOOUTPUTS_CHK (long hpib_adr, char
    *cmd_str)
550: {
560:     int     length, error_no;
570:
580:     length = strlen (cmd_str);
590:     error_no = IOOUTPUTS (hpib_adr,
    cmd_str, length);
600:     error_handler (error_no,
    "IOOUTPUTS_CHK");
610:     return error_no;
620: }
630:
640: void error_handler (int error_no, char
    *routine)
650: {
660:     char    ch;
670:
680:     if (error_no != NOERR)
690:     {
700:         printf ("Error in call to %s \n",
    routine);
710:         printf ("      Error = %d : %s \n",
    error_no, strerror (error_no));
720:         printf ("Press <ENTER> to continue
    \n");
730:         ch = getche ();
```

```

740:     exit (1);
750:   }
760: }

```

Program 5 explanation

- Line 30 Tell the compiler which file includes information on string functions.
- Line 40 Tell the compiler which file includes information on `_clearscreen()` and `_settextposition()`.
- Line 50 Tell the compiler which file includes information on `printf()`.
- Line 60 Tell the compiler which file includes information on the HP-IB Command Library I/O functions.
- Line 70 Tell the compiler which file includes information on the HP-IB Command Library error constants and `errstr()`.
- Line 90 Function prototype for the `IOOUTPUTS_CHK()` routine.
- Line 100 Function prototype for the `error_handler()` routine.
- Line 120 Define the beginning of the `main()` routine.
- Line 140 Define a string variable for the output commands.
- Line 150 Define a variable and assign it a value for the interface select code.
- Line 160 Define a variable and assign it a value for the HP-IB address of the analyzer.
- Line 170 Define a variable and assign it a value for the analyzer's passthru address.
- Line 180 Define variables for the HP-IB Command Library error status and a loop counter.
- Line 190 Define variables for the present frequency, frequency step size, and cursor value.
- Line 210 Clear the computer CRT.
- Line 230 Define a system timeout of 10 seconds.
- Line 240 Perform error trapping.
- Line 250 Abort any HP-IB transfers.
- Line 260 Perform error trapping.
- Line 270 Clear the analyzer's HP-IB interface.
- Line 280 Perform error trapping.
- Line 300 Preset the analyzer and source.
- Line 310 Tell the analyzer which instrument is controlled through the passthru address (19 is the source).
- Line 320 Put the analyzer in non-swept mode. This step is necessary when you wish to read single values. After receiving this command, the analyzer stops updating its display.
- Line 340 Define a start frequency for further measurements (in GHz).
- Line 350 Define a frequency increment (in GHz).
- Line 360 Create a formatted output by printing the CW frequency and frequency step size to a string.
- Line 370 Put the source into CW mode at the start frequency and set its frequency step size to that of the frequency increment.
- Line 380 Command the analyzer to measure reflection (input A) on channel 1. This statement also causes the analyzer to exit passthru mode.
- Line 400 Make 21 measurements, at equally-spaced CW frequencies.
- Line 420 Command the analyzer to send the current reading of channel 1 (the active channel) to the computer. The reading is taken immediately.
- Line 430 Read the value. In this instance, no format has been defined so the default format of ASCII is in effect.
- Line 440 Print the measurement number, the reading, and the frequency on the computer CRT.
- Line 450 Perform error trapping.
- Line 460 Command the source to increment the CW frequency by the step size set earlier (line 390). This is a very fast way of setting a series of equally-spaced frequencies.
- Line 470 Increment the variable that contains the current frequency. This variable is only used for printing the current frequency at each iteration of the loop.
- Line 480 End of the loop.
- Line 500 Command the source to sweep from 2 to 4 GHz. The source exits CW mode and returns to start/stop mode.
- Line 510 Command the analyzer to return to swept mode. The analyzer again updates the trace information on the display. This command also exits passthru mode.

Line 520 The end of main().

Line 540 Define a routine that outputs string commands and performs error trapping. Define the types of variables passed to this routine: `hpib_adr` is the HP-IB address, `cmd_str` is the command string to output.

Line 560 Define variables for the length of the string and the error status.

Line 580 Determine the length of the command string.

Line 590 Output the command string.

Line 600 Perform error trapping.

Line 610 Return the error status as the value of the routine.

Line 620 The end of `IOOUTPUTS_CHK()`.

Line 640 Define a routine that checks the HP-IB Command Library error status. Define the types of variables passed to this routine: `error_no` is the error value, `routine` is the HP-IB Command Library routine called.

Line 660 Define a variable to hold the keypress.

Line 680 Test if an error actually occurred.

Line 700 Yes, one did. Print on the computer CRT which HP-IB Command Library routine the error occurred in.

Line 710 Print on the computer CRT the error number and a message.

Line 720 Print a prompt on the computer CRT.

Line 730 Wait for a keypress, then continue.

Line 740 Since an error occurred, halt program execution.

Line 760 The end of `error_handler()`.

Running program 5

1. Clear the computer CRT and type in the program.
2. Press [ALT] [R] [G] on the computer.
3. The source frequency is set immediately to 2 GHz and the computer begins reading input A (reflection) of the analyzer and printing the measurements. After 21 readings, the program ends.

Program 6: trace transfer

One feature that sets the HP 8757D/E apart is its ability to transfer an entire measurement trace to a computer at very high speed. A complete, high-resolution (0.01 dB) 401-point measurement can be sent to the computer in 35 milliseconds (binary format) or 800 milliseconds (ASCII format). Transfer time will be less for fewer points per trace, and greater for more points per trace.

The analyzer gives you complete flexibility when reading measurement traces via HP-IB. You can read from the active channel and you can read the stored memory trace, the current measurement trace, or the normalized trace (measurement-minus-memory). In addition, the memory trace may be written back to the analyzer, allowing you to save and restore calibration traces via HP-IB.

With trace transfer measurements, some frequency resolution is sacrificed for measurement speed. The number of points per trace can be programmed to control the resolution across the frequency range being swept. If you are measuring a device that changes very rapidly with frequency, it is possible to miss very narrowband responses that occur between measurement points if the resolution is low. For these cases, the measurement should be made at a higher resolution. The Trace Transfer method of measurement is much faster than CW point-by-point measurements.

Program 6 listing

```

10: /* HP8757D/E QuickC IPG Program6 */
20:
30: #include <time.h>
40: #include <string.h>
50: #include <graph.h>
60: #include <stdio.h>
70: #include <cfunc.h>
80: #include <hpib.h>
90:
100: int IOOUTPUTS_CHK (long hpib_adr, char
    *cmd_str);
110: void disp_prompt (void);
120: void error_handler (int error_no, char
    *routine);
130:
140: main ()
150: {
160:     char    endlne [2],
170:            cmd [80];
180:     long    isc =7,
190:            sna =716,
200:            start_time, stop_time, the_time;
210:     int     error, elements, i,
220:            num_pts =401,
230:            binary_dat [401];
240:     float   ascii_dat [401];
250:
260:     endlne [0] =13;    /* cr */
270:     endlne [1] =10;   /* lf */
280:
290:     _clearscreen (_GCLEARSCREEN);
300:
310:     error = IOTIMEOUT (isc,10.0);
320:     error_handler (error, "IOTIMEOUT");
330:     error = IOABORT (isc);
340:     error_handler (error, "IOABORT");
350:     error = IOCLEAR (isc);
360:     error_handler (error, "IOCLEAR");
370:
380:     error = IOOUTPUTS_CHK (sna, "IP");
390:     error = IOOUTPUTS_CHK (sna, "C1IA;C2IB");
400:     start_time = time (&the_time);
410:     do
420:     {
430:         stop_time = time (&the_time);
440:     }
450:     while (stop_time - start_time <2);
460:
470:     error = IOOUTPUTS_CHK (sna, "FD2;C1OD");
480:     elements = num_pts;
490:     error = IOENTERA (sna, ascii_dat,
    &elements);
500:     error_handler (error, "IOENTERA");
510:     error = IOEOL (isc, endlne, 0);
520:     error_handler (error, "IOEOL");
530:     error = IOOUTPUTS_CHK (sna, "C1WM");
540:     error = IOEOL (isc, endlne, 2);
550:     error_handler (error, "IOEOL");
560:     elements = num_pts;
570:     error = IOOUTPUTA (sna, ascii_dat, elements);
580:     error_handler (error, "IOOUTPUTA");
590:     error = IOOUTPUTS_CHK (sna, "C1MY");
600:     disp_prompt ();
610:
620:     error = IOOUTPUTS_CHK (sna, "C1C0;C2MY");
630:     error = IOOUTPUTS_CHK (sna, "FD3;C2OD");
640:     elements =2 * num_pts;
650:     error = IOENTERB (sna, binary_dat,
    &elements, 1);
660:     error_handler (error, "IOENTERB");
670:     error = IOEOL (isc, endlne, 0);
680:     error_handler (error, "IOEOL");
690:     error = IOOUTPUTS_CHK (sna, "C2WM");
700:     error = IOEOL (isc, endlne, 2);
710:     error_handler (error, "IOEOL");
720:     elements =2 * num_pts;
730:     error = IOOUTPUTB (sna, binary_dat,
    elements, 1);
740:     error_handler (error, "IOOUTPUTB");
750:     disp_prompt ();
760:
770:     for (i = 0; i < num_pts; i = i+1)
780:     {
790:         binary_dat [i] = i %100;
800:     }

```

```

810:     error = IOOUTPUTS_CHK (sna, "C2C0;C1MY");
820:     error = IOEOL (isc, endlne, 0);
830:     error_handler (error, "IOEOL");
840:     error = IOOUTPUTS_CHK (sna, "FD3;C1WM");
850:     error = IOEOL (isc, endlne, 2);
860:     error_handler (error, "IOEOL");
870:     elements =2 * num_pts;
880:     error = IOOUTPUTB (sna, binary_dat,
    elements, 1);
890:     error_handler (error, "IOOUTPUTB");
900:     error = IOOUTPUTS_CHK (sna, "AS");
910: }
920:
930: int IOOUTPUTS_CHK (long hpib_adr, char
    *cmd_str)
940: {
950:     int    length, error_no;
960:
970:     length = strlen (cmd_str);
980:     error_no = IOOUTPUTS_CHK (hpib_adr,
    cmd_str, length);
990:     error_handler (error_no,
    "IOOUTPUTS_CHK");
1000:     return error_no;
1010: }
1020:
1030: void disp_prompt (void)
1040: {
1050:     char ch;
1060:
1070:     settexposition (25,1);
1080:     printf ("Press <ENTER> to continue
    \n");
1090:     ch = getche ();
1100:     _clearscreen (_GCLEARSCREEN);
1110: }
1120:
1130: void error_handler (int error_no, char
    *routine)
1140: {
1150:     char ch;
1160:
1170:     if (error_no != NOERR)
1180:     {
1190:         printf ("Error in call to %s\n",
            routine);
1200:         printf ("      Error = %d : %s
    \n", error_no, errstr (error_no));
1210:         printf ("Press <ENTER> to
            continue\n");
1220:         ch = getche ();
1230:         exit (1);
1240:     }
1250: }

```

Program 6 explanation

- Line 30 Tell the compiler which file includes information on time functions.
- Line 40 Tell the compiler which file includes information on string functions.
- Line 50 Tell the compiler which file includes information on `_clearscreen()` and `_settextposition()`.
- Line 60 Tell the compiler which file includes information on `printf()`.
- Line 70 Tell the compiler which file includes information on the HP-IB Command Library I/O functions.
- Line 80 Tell the compiler which file includes information on the HP-IB Command Library error constants and `errstr()`.
- Line 100 Function prototype for the `IOOUTPUTS_CHK()` routine.

Line 110	Function prototype for the disp_prompt() routine.	Line 410	Start of do loop.
Line 120	Function prototype for the error_handler() routine.	Line 430	Get the present time.
Line 140	Define the beginning of the main() routine.	Line 450	Loop until 2 seconds have elapsed from the start time.
Line 160	Define a string variable for the HP-IB command end-of-line string.	Line 470	Set the data format to Extended ASCII and command the analyzer to output the channel 1 measurement data.
Line 170	Define a string variable for the output commands.	Line 480	Determine the number of elements to be read into the array.
Line 180	Define a variable and assign it a value for the interface select code.	Line 490	Read the measurement trace data from channel 1.
Line 190	Define a variable and assign it a value for the HP-IB address of the analyzer.	Line 500	Perform error trapping.
Line 200	Define variables for the start, stop, and present time.	Line 510	Disable the end-of-line string (carriage return/linefeed) that is sent after any IOOUTPUT command.
Line 210	Define variables for the HP-IB Command Library error status, the number of elements in an array, and a loop counter.	Line 520	Perform error trapping.
Line 220	Define a variable and assign it a value for the number of trace points on the analyzer. By using a variable here it helps to make the program easily adaptable to different numbers of trace points.	Line 530	Command the analyzer to input data into the trace memory of channel 1.
Line 230	Define an array to hold a trace of 401 points in binary format.	Line 540	Enable the end-of-line string (carriage return/linefeed) that is sent after any IOOUTPUT command.
Line 240	Define an array to hold a trace of 401 points in ASCII format.	Line 550	Perform error trapping.
Line 260	Define the end-of-line string as a carriage return and linefeed.	Line 560	Determine the number of elements in the array to be sent.
Line 290	Clear the computer CRT.	Line 570	Write the measured trace data back to the trace memory of channel 1. Reading the measurement trace and storing it back into trace memory is equivalent to executing the MEAS --> MEM function (HP-IB command SM).
Line 310	Define a system timeout of 10 seconds.	Line 580	Perform error trapping.
Line 320	Perform error trapping.	Line 590	Command channel 1 to display the trace memory data.
Line 330	Abort any HP-IB transfers.	Line 600	Wait until [ENTER] is pressed to continue.
Line 340	Perform error trapping.	Line 620	Turn channel 1 off and channel 2 on. Command the analyzer to display the trace memory from channel 2.
Line 350	Clear the analyzer's HP-IB interface.	Line 630	Set the data format to PC binary format. Command the analyzer to output its channel 2 measurement trace data.
Line 360	Perform error trapping.	Line 640	Determine the number of bytes used in the binary trace transfer.
Line 380	Preset the analyzer and the source. This sets the number of points per trace to 401.	Line 650	Read the binary measurement data from channel 2.
Line 390	Set channel 1 to reflection (input A) and channel 2 to transmission (input B).		
Line 400	Set the start time using the time function.		

Line 660 Perform error trapping.

Line 670 Disable the end-of-line string (carriage return/linefeed) that is sent after any IOOUTPUT command.

Line 680 Perform error trapping.

Line 690 Command the analyzer to input data into the trace memory of channel 2.

Line 700 Enable the end-of-line string (carriage return/linefeed) that is sent after any IOOUTPUT command.

Line 710 Perform error trapping.

Line 720 Determine the number of bytes used in the binary trace transfer.

Line 730 Write the binary data array back to the trace memory of channel 2.

Line 740 Perform error trapping.

Line 750 Wait until [ENTER] is pressed to continue.

Line 770 Set up a loop to create 401 measurement points.

Line 790 Calculate some arbitrary function and fill the binary data array. This function has no particular meaning, but represents some special calibration data (such as an open/short average).

Line 800 End of the loop.

Line 810 Turn channel 2 off and display the channel 1 trace memory.

Line 820 Disable the end-of-line string (carriage return/linefeed) that is sent after any IOOUTPUT command.

Line 830 Perform error trapping.

Line 840 Command the analyzer to input data into the trace memory of channel 1.

Line 850 Enable the end-of-line string (carriage return/linefeed) that is sent after any IOOUTPUT command.

Line 860 Perform error trapping.

Line 870 Determine the number of bytes used in the binary trace transfer.

Line 880 Write the binary data array to the trace memory of channel 1.

Line 890 Perform error trapping.

Line 900 Autoscale the display on channel 1.

Line 910 The end of main().

Line 930 Define a routine that outputs string commands and performs error trapping. Define the types of variables passed to this routine: hpib_adr is the HP-IB address, cmd_str is the command string to output.

Line 950 Define variables for the length of the string and the error status.

Line 970 Determine the length of the command string.

Line 980 Output the command string.

Line 990 Perform error trapping.

Line 1000 Return the error status as the value of the routine.

Line 1010 The end of IOOUTPUTS_CHK().

Line 1030 Define a routine that prints a prompt on the computer CRT and waits for [ENTER] to be pressed.

Line 1050 Define a variable to hold the keypress.

Line 1070 Locate the text cursor at the beginning of row 25.

Line 1080 Print a prompt on the computer CRT.

Line 1090 Wait for a keypress, then continue.

Line 1100 Clear the computer CRT.

Line 1110 The end of disp_prompt().

Line 1130 Define a routine that checks the HP-IB Command Library error status. Define the types of variables passed to this routine: error_no is the error value, routine is the HP-IB Command Library routine called.

Line 1150 Define a variable to hold the keypress.

Line 1170 Test if an error actually occurred.

Line 1190 Yes, one did. Print on the computer CRT which HP-IB Command Library routine the error occurred in.

Line 1200 Print on the computer CRT the error number and a message.

Line 1210 Print a prompt on the computer CRT.

Line 1220 Wait for a keypress, then continue.

Line 1230 Since an error occurred, halt program execution.

Line 1250 The end of error_handler().

Running program 6

1. Clear the computer CRT and type in the program.
2. Press [ALT] [R] [G] on the computer.
3. Watching the analyzer CRT, you will see DATA DUMP TO HP-IB when it begins sending trace data to the computer, and DATA DUMP TO TRACE MEMORY when the computer sends the data back.
4. Watching the analyzer CRT, press [ENTER] on the computer. The computer again reads and writes a trace of data. The analyzer displays the same messages. This time the transfer occurs much more rapidly. A binary transfer takes about 35 milliseconds to be completed each way, while an ASCII transfer requires about 800 milliseconds each way.
5. Press [ENTER] on the computer. The computer calculates an arbitrary function and sends it to a trace memory of the analyzer, where it is autoscaled and displayed. This function has no significance. It represents a special calibration trace, such as an open/short average. With a computer, the analyzer measurement system may be calibrated over several different frequency ranges and changed from one to another very quickly, without recalibration.

If you wish to transfer a higher resolution trace with the HP 8757D, modify line 380 to be "IP SP801" for 801 points. Then modify the "401" in lines 220, 230, and 240 to "801".

Program 7: using the TAKE SWEEP command

The computer can detect this event in two ways:

- Monitor the status byte continuously until the bit is set (polling).
- Let the analyzer generate a service request (SRQ) and interrupt the computer.

Table1 is a diagram of the status bytes of the analyzer. It shows all of the bits that can be used to either monitor or interrupt the computer. Unfortunately, Microsoft QuickC is unable to automatically detect SRQ interrupts so the only approach available is to monitor the status byte. In this program, bit 4 (decimal value16) is used to signal "operation complete" (all of the sweeps specified by the TAKE SWEEP command have been completed).

When you follow the take sweep command with an output statement, such as OUTPUT DATA (OD), the data is sent immediately, not after the instructed number of sweeps. The approach mentioned overcomes this by letting us send the data at the end of the specified number of sweeps, not immediately. Another approach is to use the sweep hold mode (SW2) instead of the non-swept mode (SW0). In this mode the analyzer will prevent any HP-IB operations until the completion of the TAKE SWEEP command.

Table 1. HP 8757D/E Status Byte Descriptions

STATUS BYTE (#1)								
BIT #	7	6	5	4	3	2	1	0
Decimal Value	128	64	32	16	8	4	2	1
Function	N/A	Request Service (SRQ)	SRQ on HP-IB Syntax Error	SRQ on Operation Complete (Sweep, Plot or Print)	SRQ on Softkey Only Pressed	SRQ on Change in Extended Status Byte	SRQ on Numeric Entry Completed (HP-IB or Front Panel)	SRQ on Any Front Panel Key Pressed
EXTENDED STATUS BYTE (#2)								
BIT #	7	6	5	4	3	2	1	0
Decimal Value	128	64	32	16	8	4	2	1
Function	N/A	SRQ on Detector Uncal	SRQ on Front Panel Preset or Power-on	SRQ on Limit Test Failed ¹	SRQ on Action Requested not possible	SRQ on Knob Activity	SRQ on Operation Failed ¹	SRQ on Self Test Failure

1. HP 8757D only.

Program 7 listing

```

10: /* HP8757D/E QuickC IPG Program7 */
20:
30: #include <string.h>
40: #include <graph.h>
50: #include <stdio.h>
60: #include <cfunc.h>
70: #include <chpib.h>
80:
90: int IOOUTPUTS_CHK (long hpib_adr, char
    *cmd_str);
100: void error_handler (int error_no, char
    *routine);
110:
120: main ()
130: {
140:     char    cmd [80];
150:     long    isc =7,
160:            sna =716,
170:            passthru =717;
180:     int     error, elements, status;
190:     float   ascii_dat [401];
200:
210:     _clearscreen (_GCLEARSCREEN);
220:
230:     error = IOTIMEOUT (isc,10.0);
240:     error_handler (error, "IOTIMEOUT");
250:     error = IOABORT (isc);
260:     error_handler (error, "IOABORT");
270:     error = IOCLEAR (isc);
280:     error_handler (error, "IOCLEAR");
290:
300:     error = IOOUTPUTS_CHK (sna, "IP");
310:     error = IOOUTPUTS_CHK (sna, "PT19;");
320:     error = IOOUTPUTS_CHK (passthru,
        "ST250MS");
330:     error = IOOUTPUTS_CHK (sna, "C2C0IB");
340:     error = IOOUTPUTS_CHK (sna,
        "SW0;CS;RM16;");
350:     error = IOOUTPUTS_CHK (sna, "TS10;");
360:     do
370:     {
380:         error = IOS POLL (sna, &status);
390:         error_handler (error, "IOS POLL");
400:     }
410:     while ((status &16) == 0);
420:     error = IOOUTPUTS_CHK (sna, "FD2;C10D");
430:     elements =401;
440:     error = IOENTERA (sna, ascii_dat,
        &elements);
450:     error_handler (error, "IOENTERA");
460:     error = IOOUTPUTS_CHK (sna, "SW1");
470: }
480:
490: int IOOUTPUTS_CHK (long hpib_adr, char
    *cmd_str)
500: {
510:     int    length, error_no;
520:
530:     length = strlen (cmd_str);
540:     error_no = IOOUTPUTS (hpib_adr,
        cmd_str, length);
550:     error_handler (error_no,
        "IOOUTPUTS_CHK");
560:     return error_no;
570: }
580:
590: void error_handler (int error_no, char
    *routine)
600: {
610:     char ch;
620:
630:     if (error_no != NOERR)
640:     {
650:         printf ("Error in call to %s \n",
            routine);
660:         printf ("      Error = %d : %s \n",
            error_no, strerror (error_no));
670:         printf ("Press <ENTER> to
            continue\n");
680:         ch = getche ();
690:         exit (1);
700:     }
710: }

```

Program 7 explanation

- Line 30 Tell the compiler which file includes information on string functions.
- Line 40 Tell the compiler which file includes information on _clearscreen() and _settextposition().
- Line 50 Tell the compiler which file includes information on printf().

- Line 60 Tell the compiler which file includes information on the HP-IB Command Library I/O functions.
- Line 70 Tell the compiler which file includes information on the HP-IB Command Library error constants and `errstr()`.
- Line 90 Function prototype for the `IOOUTPUTS_CHK()` routine.
- Line 100 Function prototype for the `error_handler()` routine.
- Line 120 Define the beginning of the `main()` routine.
- Line 140 Define a string variable for the output commands.
- Line 150 Define a variable and assign it a value for the interface select code.
- Line 160 Define a variable and assign it a value for the HP-IB address of the analyzer.
- Line 170 Define a variable and assign it a value for the analyzer's passthru address.
- Line 180 Define variable for the HP-IB Command Library error status, the number of elements in an array, and the analyzer's status byte.
- Line 190 Define an array to hold a trace of 401 points in ASCII format.
- Line 210 Clear the computer CRT.
- Line 230 Define a system timeout of 10 seconds.
- Line 240 Perform error trapping.
- Line 250 Abort any HP-IB transfers.
- Line 260 Perform error trapping.
- Line 270 Clear the analyzer's HP-IB interface.
- Line 280 Perform error trapping.
- Line 300 Preset the analyzer and source.
- Line 310 Tell the analyzer which instrument is controlled through the passthru address (19 is the source).
- Line 320 Set the source to 250 milliseconds per sweep.
- Line 330 Turn off channel 2 of the analyzer and select transmission (input B) for display on channel 1.
- Line 340 Put the analyzer into non-swept mode. Clear the status register of the analyzer. Set the request mask to 16 (bit 4) so that the analyzer will set bit 4 (operation complete) at the completion of the TAKE SWEEP command. Table 1 has a description of all bits in the status bytes.
- Line 350 Command the analyzer to take 10 sweeps.
- Line 360 Start of do loop.
- Line 380 Read the analyzer status byte.
- Line 390 Perform error trapping.
- Line 410 Wait for the 10 sweeps to be completed by testing the status byte to see if bit 4 is set. Remain in the loop until bit 4 (decimal 16) is set.
- Line 420 Set the data format to Extended ASCII and command the analyzer to output the channel 1 trace data.
- Line 430 Define the maximum number of elements to be read into an array.
- Line 440 Read the trace data.
- Line 450 Perform error trapping.
- Line 460 Return the analyzer to swept mode. The display now updates continuously.
- Line 470 The end of `main()`.
- Line 490 Define a routine that outputs string commands and performs error trapping. Define the types of variables passed to this routine: `hpib_adr` is the HP-IB address, `cmd_str` is the command string to output.
- Line 510 Define variables for the length of the string and the error status.
- Line 530 Determine the length of the command string.
- Line 540 Output the command string.
- Line 550 Perform error trapping.
- Line 560 Return the error status as the value of the routine.
- Line 570 The end of `IOOUTPUTS_CHK()`.
- Line 590 Define a routine that checks the HP-IB Command Library error status. Define the types of variables passed to this routine: `error_no` is the error value, routine is the HP-IB Command Library routine called.
- Line 610 Define a variable to hold the keypress.

Line 630 Test if an error actually occurred.

Line 650 Yes, one did. Print on the computer CRT which HP-IB Command Library routine the error occurred in.

Line 660 Print on the computer CRT the error number and a message.

Line 670 Print a prompt on the computer CRT.

Line 680 Wait for a keypress, then continue.

Line 690 Since an error occurred, halt program execution.

Line 710 The end of error_handler().

Running program 7

1. Clear the computer CRT and type in the program.
2. Press [ALT] [R] [G] on the computer.
3. The computer first presets the analyzer and source, then sets the source to 250 milliseconds per sweep, and the analyzer to display transmission on channel 1.
4. The computer commands the analyzer to take 10 sweeps and polls the analyzer status byte to determine when they were completed. The computer reads a trace from the analyzer. Just before the trace is sent, you should see the display "freeze" as the TAKE SWEEP command is completed.

To use the sweep hold mode, modify line 340 to "SW2;" (instead of "SW0;CS;RM16;") and delete lines 360, 370, 380, 390, 400, and 410. The program will wait at line 420 until the 10 sweeps are completed.

Program 8: programming the softkeys

The HP 8757D/E has eight screen-labeled softkeys that make measurements faster and easier for users. Under HP-IB control, you can re-label the softkeys with any annotation and sense when they are pressed.

Use the softkeys to branch to special measurement programs. By making full use of the softkeys, your automatic system may not need a normal computer keyboard at all, making it as easy to use as a manual instrument.

Program 8 listing

```

10: /* HP8757D/E QuickC IPG Program8 */
20:
30: #include <string.h>
40: #include <graph.h>
50: #include <stdio.h>
60: #include <cfunc.h>
70: #include <chpib.h>
80:
90: int IOOUTPUTS_CHK (long hpib_adr, char
    *cmd_str);

```

```

100: void error_handler (int error_no, char
    *routine);
110:
120: main ()
130: {
140:     char    cmd [80];
150:     long    isc =7,
160:            sna =716;
170:     int     error, elements,
180:            status, keycode;
190:     float   value;
200:
210:     _clearscreen (_GCLEARSCREEN);
220:
230:     error = IOTIMEOUT (isc,10.0);
240:     error_handler (error, "IOTIMEOUT");
250:     error = IOABORT (isc);
260:     error_handler (error, "IOABORT");
270:     error = IOCLEAR (isc);
280:     error_handler (error, "IOCLEAR");
290:
300:     error = IOOUTPUTS_CHK (sna, "IP");
310:     error = IOOUTPUTS_CHK (sna, "CS;RM8;");
320:     error = IOOUTPUTS_CHK (sna, "WK1 CALL1");
330:     error = IOOUTPUTS_CHK (sna, "WK2 TEST1");
340:     error = IOOUTPUTS_CHK (sna, "WK3 CAL2");
350:     error = IOOUTPUTS_CHK (sna, "WK4 TEST2");
360:     error = IOOUTPUTS_CHK (sna, "WK8 ABORT");
370:     printf ("SOFT KEYS LOADED\n");
380:
390:     do
400:     {
410:         status = 0;
420:         do
430:         {
440:             error = IOS POLL (sna, &status);
450:             error_handler (error, "IOS POLL");
460:         }
470:         while ((status &8) == 0);
480:         error = IOOUTPUTS_CHK (sna, "OK");
490:         error = IOENTER (sna, &value);
500:         error_handler (error, "IOENTER");
510:         keycode = value;
520:         _clearscreen (_GCLEARSCREEN);
530:         _settextposition (12,29);
540:         switch (keycode)
550:         {
560:             case32:
570:                 printf ("Calibration #1\n");
580:                 break;
590:             case8:
600:                 printf ("Test #1\n");
610:                 break;
620:             case 0:
630:                 printf ("Calibration #2\n");
640:                 break;
650:             case16:
660:                 printf ("Test #2\n");
670:                 break;
680:             case41:
690:                 printf ("Abort\n");
700:                 break;
710:             default:
720:                 printf ("*** Undefined ***\n");
730:                 break;
740:         }
750:         error = IOOUTPUTS_CHK (sna, "CS");
760:     }
770:     while (keycode !=41);
780: }
790:
800: int IOOUTPUTS_CHK (long hpib_adr, char
    *cmd_str)
810: {
820:     int     length, error_no;
830:
840:     length = strlen (cmd_str);
850:     error_no = IOOUTPUTS (hpib_adr,
    cmd_str, length);
860:     error_handler (error_no,
    "IOOUTPUTS_CHK");
870:     return error_no;
880: }
890:
900: void error_handler (int error_no, char
    *routine)
910: {
920:     char    ch;
930:
940:     if (error_no != NOERR)

```

```

950:      {
960:          printf ("Error in call to %s \n",
routine);
970:          printf ("      Error = %d : %s \n",
error_no, errstr (error_no));
980:          printf ("Press <ENTER> to
continue\n");
990:          ch = getche ();
1000:          exit (1);
1010:      }
1020:  }

```

Program 8 explanation

- | | | | |
|----------|--|----------|--|
| Line 30 | Tell the compiler which file includes information on string functions. | Line 260 | Perform error trapping. |
| Line 40 | Tell the compiler which file includes information on <code>_clearscreen()</code> and <code>_settextposition()</code> . | Line 270 | Clear the analyzer's HP-IB interface. |
| Line 50 | Tell the compiler which file includes information on <code>printf()</code> . | Line 280 | Perform error trapping. |
| Line 60 | Tell the compiler which file includes information on the HP-IB Command Library I/O functions. | Line 300 | Preset the analyzer and source. |
| Line 70 | Tell the compiler which file includes information on the HP-IB Command Library error constants and <code>errstr()</code> . | Line 310 | Set the request mask to 8 (bit 3). See Table 1 for the description of the status bytes. |
| Line 90 | Function prototype for the <code>IOOUTPUTS_CHK()</code> routine. | Line 320 | Label softkey 1 with "CAL1". Softkey 1 is the softkey at the top of the CRT. |
| Line 100 | Function prototype for the <code>error_handler()</code> routine. | Line 330 | Label softkey 2 with "TEST1". |
| Line 120 | Define the beginning of the <code>main()</code> routine. | Line 340 | Label softkey 3 with "CAL 2". |
| Line 140 | Define a string variable for the output commands. | Line 350 | Label softkey 4 with "TEST 2". |
| Line 150 | Define a variable and assign it a value for the interface select code. | Line 360 | Label softkey 8 with "ABORT". |
| Line 160 | Define a variable and assign it a value for the HP-IB address of the analyzer. | Line 370 | Print a message to the user. |
| Line 170 | Define variables for the HP-IB Command Library error status and the number of elements in an array. | Line 390 | Start of do loop. |
| Line 180 | Define variables for the analyzer's status byte and the keycode of the softkey pressed. | Line 410 | Set status variable to zero. |
| Line 190 | Define a variable for reading the keycode value. | Line 420 | Start of do loop. |
| Line 210 | Clear the computer CRT. | Line 440 | Read the analyzer status byte. |
| Line 230 | Define a system timeout of 10 seconds. | Line 450 | Perform error trapping. |
| Line 240 | Perform error trapping. | Line 470 | Wait for a softkey to be pressed by testing the status byte to see if bit 3 is set. Remain in the loop until bit 3 (decimal 8) is set. |
| Line 250 | Abort any HP-IB transfers. | Line 480 | Command the analyzer to output the key code of the last key pressed. |
| | | Line 490 | Read the key code. |
| | | Line 500 | Perform error trapping. |
| | | Line 510 | Make the key code an integer value. |
| | | Line 520 | Clear the computer CRT. |
| | | Line 530 | Move the text cursor to row 12, column 29, on the computer CRT. |
| | | Line 540 | Multi-way branch on key code value. |
| | | Line 560 | If the key code is 32, then softkey 1 was pressed. |
| | | Line 570 | Print an appropriate message on the computer CRT. |
| | | Line 580 | Exit the switch statement. |
| | | Line 590 | If the key code is 8, then softkey 2 was pressed. |

Line 600 Print an appropriate message on the computer CRT.

Line 610 Exit the switch statement.

Line 620 If the key code is 0, then softkey 3 was pressed.

Line 630 Print an appropriate message on the computer CRT.

Line 640 Exit the switch statement.

Line 650 If the key code is 16, then softkey 4 was pressed.

Line 660 Print an appropriate message on the computer CRT.

Line 670 Exit the switch statement.

Line 680 If the key code is 41, then softkey 8 was pressed.

Line 690 Print an appropriate message on the computer CRT.

Line 700 Exit the switch statement.

Line 710 If the key code doesn't match any of the preceding codes, another key was pressed. In this case, the key code has to be for softkey 5, 6, or 7 (key codes 14, 38, or 40) since these are the only other keys that impact the analyzer's status byte.

Line 720 Print an appropriate message on the computer CRT.

Line 730 Exit the switch statement.

Line 740 End of multi-way branch.

Line 750 Command the analyzer to clear the status byte.

Line 770 Wait for the "Abort" softkey to be pressed by testing the key code to see if is 41. Remain in the loop until this is true.

Line 780 The end of main().

Line 800 Define a routine that outputs string commands and performs error trapping. Define the types of variables passed to this routine: `hpib_adr` is the HP-IB address, `cmd_str` is the command string to output.

Line 820 Define variables for the length of the string and the error status.

Line 840 Determine the length of the command string.

Line 850 Output the command string.

Line 860 Perform error trapping.

Line 870 Return the error status as the value of the routine.

Line 880 The end of `IOOUTPUTS_CHK()`.

Line 900 Define a routine that checks the HP-IB Command Library error status. Define the types of variables passed to this routine: `error_no` is the error value, routine is the HP-IB Command Library routine called.

Line 920 Define a variable to hold the keypress.

Line 940 Test if an error actually occurred.

Line 960 Yes, one did. Print on the computer CRT which HP-IB Command Library routine the error occurred in.

Line 970 Print on the computer CRT the error number and a message.

Line 980 Print a prompt on the computer CRT.

Line 990 Wait for a keypress, then continue.

Line 1000 Since an error occurred, halt program execution.

Line 1020 The end of `error_handler()`.

Running program 8

1. Clear the computer CRT and type in the program.
2. Press [ALT] [R] [G] on the computer.
3. After the computer presets the analyzer and the source, it writes the softkey labels on the analyzer CRT. When the first key label is written, the analyzer labels it and blanks the other softkey labels. Since all labels except softkeys 5, 6, and 7 are given new labels, softkeys 5, 6, and 7 remain blank.
4. Press any key on the analyzer. Pressing a softkey causes a message to be printed on the CRT of the computer. Note that softkeys 5, 6, and 7 generate an interrupt, even though they weren't labeled. No other keys of the analyzer generate an interrupt, because of the SRQ mask specified.

Because the analyzer was left in remote mode, it didn't respond to any keys pressed on its front panel. In some applications it is useful to put the analyzer into local operation, so that it can be controlled from the front panel and still generate interrupts whenever a key is pressed.

Program 9: CRT graphics

For applications requiring diagrams, drawings, or special limit lines, the CRT of the analyzer may be used as a plotter.

This program draws a connection diagram for a hypothetical test system measuring an amplifier. It will blank the analyzer's standard display containing the graticule, annotation, and softkeys so that we have a blank CRT. Figure 2 shows what the CRT should look like when the program is done.

For fast, easy-to-use graphics, the graphics memory of the HP 8757D/E is divided into seven "pages" of 500 words. One vector requires two words. Each of the pages may be selected to receive data, and turned on and off independently. You can keep different drawings in each of the graphics memory pages and simply turn on the drawing you need by turning on the appropriate page. Each page may also be erased independently.

To use the graphics capability of the HP 8757D/E, first define the passthru address to be one less than the analyzer's control address. If the analyzer's address is 16, its graphics address is 15. To the computer, the CRT of the analyzer looks like a plotter connected to the 8757 SYSTEM INTERFACE.

CONNECTION DIAGRAM

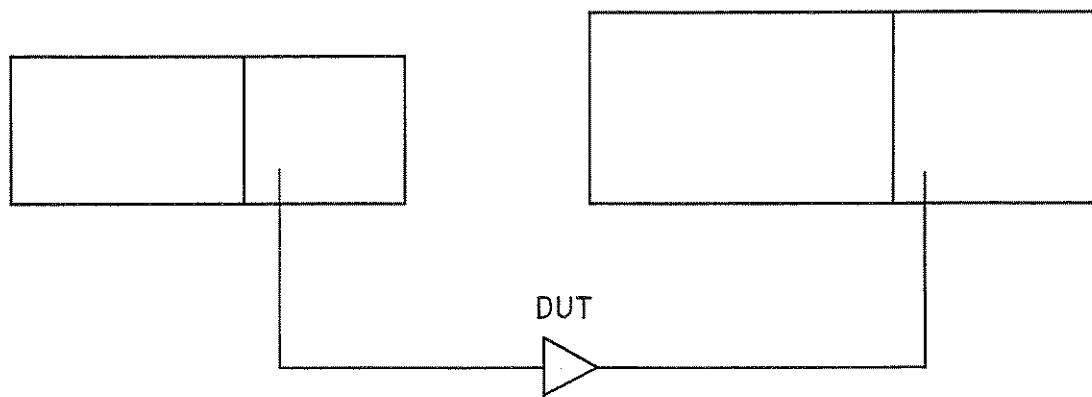

Figure 2. The CRT Graphics Display.

Program 9 listing

```
10: /* HP8757D/E QuickC IPG Program9 */
20:
30: #include <string.h>
40: #include <graph.h>
50: #include <stdio.h>
60: #include <cfunc.h>
70: #include <chpib.h>
80:
90: int IOOUTPUTS_CHK (long hpib_adr, char
    *cmd_str);
100: void error_handler (int error_no, char
    *routine);
110:
120: main ()
130: {
140:     char    cmd [80];
150:     long    isc =7,
160:            sna =716,
170:            passthru =717;
180:     int     error, col, row;
190:
200:     _clearscreen (_GCLEARSCREEN);
210:
220:     error = IOTIMEOUT (isc,10.0);
230:     error_handler (error, "IOTIMEOUT");
240:     error = IOABORT (isc);
250:     error_handler (error, "IOABORT");
260:     error = IOCLEAR (isc);
270:     error_handler (error, "IOCLEAR");
280:
290:     error = IOOUTPUTS_CHK (sna, "IP BL5
    PT15;");
300:     error = IOOUTPUTS_CHK (passthru,
    "EP;GP1,1;DF;");
310:     error = IOOUTPUTS_CHK (passthru, "SP9;");
320:
330:     for (col = 0; col <=29; col = col +1)
340:     {
350:         sprintf (cmd,
    "PU;PA%d,0;PD;PA%d,2000;", col *
    100, col *100);
360:         error = IOOUTPUTS_CHK (passthru, cmd);
370:     }
380:     for (row = 0; row <=20; row = row +1)
390:     {
400:         sprintf (cmd, "PU;PA 0,%d;PD;PA
    2900,%d;", row *100, row *100);
410:         error = IOOUTPUTS_CHK (passthru, cmd);
420:     }
430:     error = IOOUTPUTS_CHK (passthru, "SP1");
440:     error = IOOUTPUTS_CHK (passthru, "PU;PA
    600,1600;PD");
450:     error = IOOUTPUTS_CHK (passthru,
    "SIO.28,0.34;LBCONNECTION DIAGRAM\3");
460:     error = IOOUTPUTS_CHK (passthru, "PU;PA
    1200,250;PD");
470:     error = IOOUTPUTS_CHK (passthru,
    "SIO.28,0.34;LBDUT\3");
480:     error = IOOUTPUTS_CHK (passthru, "PU;PA
    300,800;PD;PA 1100,800,1100,1100,300,
    1100,300,800");
490:     error = IOOUTPUTS_CHK (passthru, "PU;PA
    800,800;PD;PA800,1100");
500:     error = IOOUTPUTS_CHK (passthru, "PU;PA
    1500,800;PD;PA2300,800,2300,1200,1500,
    1200,1500,800");
510:     error = IOOUTPUTS_CHK (passthru, "PU;PA
    1950,800;PD;PA1950,1200");
520:     error = IOOUTPUTS_CHK (passthru, "PU;PA
    875,850;PD;PA875,500,1200,500");
```

```

530: error = IOOUTPUTS_CHK (passthru, "PU;PA
1400,500;PD;PA2050,500,2050,850");
540: error = IOOUTPUTS_CHK (passthru, "PU;PA
1200,400;PD;PA1400,500,1200,600,1200,400");
550: error = IOOUTPUTS_CHK (passthru, "PU;PA
0,0");
560: error = IOCLEAR (sna);
570: error_handler (error, "IOCLEAR");
580: }
590:
600: int IOOUTPUTS_CHK (long hpib_adr, char
*cmd_str)
610: {
620:     int    length, error_no;
630:
640:     length = strlen (cmd_str);
650:     error_no = IOOUTPUTS (hpib_adr,
cmd_str, length);
660:     error_handler (error_no, "IOOUTPUTS_CHK");
670:     return error_no;
680: }
690:
700: void error_handler (int error_no, char
*routine)
710: {
720:     char  ch;
730:
740:     if (error_no != NOERR)
750:     {
760:         printf ("Error in call to %s \n",
routine);
770:         printf ("      Error = %d : %s \n",
error_no, strerror (error_no));
780:         printf ("Press <ENTER> to
continue\n");
790:         ch = getche ();
800:         exit (1);
810:     }
820: }

```

Program 9 explanation

- | | |
|--|---|
| <p>Line 30 Tell the compiler which file includes information on string functions.</p> <p>Line 40 Tell the compiler which file includes information on <code>_clearscreen()</code> and <code>_settextposition()</code>.</p> <p>Line 50 Tell the compiler which file includes information on <code>printf()</code>.</p> <p>Line 60 Tell the compiler which file includes information on the HP-IB Command Library I/O functions.</p> <p>Line 70 Tell the compiler which file includes information on the HP-IB Command Library error constants and <code>errstr()</code>.</p> <p>Line 90 Function prototype for the <code>IOOUTPUTS_CHK()</code> routine.</p> <p>Line 100 Function prototype for the <code>error_handler()</code> routine.</p> <p>Line 120 Define the beginning of the <code>main()</code> routine.</p> <p>Line 140 Define a string variable for the output commands.</p> <p>Line 150 Define a variable and assign it a value for the interface select code.</p> | <p>Line 160 Define a variable and assign it a value for the HP-IB address of the analyzer.</p> <p>Line 170 Define a variable and assign it a value for the analyzer's passthru address.</p> <p>Line 180 Define variables for the HP-IB Command Library error status, the CRT column and row.</p> <p>Line 200 Clear the computer CRT.</p> <p>Line 220 Define a system timeout of 10 seconds.</p> <p>Line 230 Perform error trapping.</p> <p>Line 240 Abort any HP-IB transfers.</p> <p>Line 250 Perform error trapping.</p> <p>Line 260 Clear the analyzer's HP-IB interface.</p> <p>Line 270 Perform error trapping.</p> <p>Line 290 Preset the analyzer and blank the CRT display. Define the CRT graphics as the target of passthru commands. The CRT graphics address is always one less than the analyzer's HP-IB address.</p> <p>Line 300 Erase all graphics pages. Turn graphics page 1 on to ensure that the graphics start in it. Set the color selection to default monochrome colors.</p> <p>Line 310 Select to plot with pen 9, the lowest intensity for the analyzer CRT.</p> <p>Line 330 Loop 30 times to draw the vertical part of the grid.</p> <p>Line 350 Create a formatted output by printing the HP-GL plotter commands to a string.</p> <p>Line 360 Draw a vertical line down the CRT.</p> <p>Line 370 End of the loop.</p> <p>Line 380 Loop 21 times to draw the horizontal part of the grid.</p> <p>Line 400 Create a formatted output by printing the HP-GL plotter commands to a string.</p> <p>Line 410 Draw a horizontal line across the CRT.</p> <p>Line 420 End of the loop.</p> <p>Line 430 Select to plot with pen 1, the brightest intensity for the analyzer CRT.</p> <p>Line 440 Move the pen to title the display.</p> |
|--|---|

Line 450 Specify the width and height of each character, indicate what the title is, terminate the title with an end-of-text character (decimal 3).

Line 460 Move the pen to label the DUT.

Line 470 Specify the width and height of each character, indicate what the title is, terminate the title with an end-of-text character (decimal 3).

Line 480 Move the pen and draw the outline of the source.

Line 490 Draw the plug-in of the source.

Line 500 Move the pen and draw the outline of the analyzer.

Line 510 Draw the CRT of the analyzer.

Line 520 Draw the connections from the source to the DUT.

Line 530 Draw the connections from the DUT to the analyzer.

Line 540 Draw the DUT (an amplifier).

Line 550 Move to the bottom left corner of the CRT.

Line 560 Exit passthru mode by clearing the analyzer's HP-IB interface.

Line 570 Perform error trapping.

Line 580 The end of main().

Line 600 Define a routine that outputs string commands and performs error trapping. Define the types of variables passed to this routine: `hpib_adr` is the HP-IB address, `cmd_str` is the command string to output.

Line 620 Define variables for the length of the string and the error status.

Line 640 Determine the length of the command string.

Line 650 Output the command string.

Line 660 Perform error trapping.

Line 670 Return the error status as the value of the routine.

Line 680 The end of `IOOUTPUTS_CHK()`.

Line 700 Define a routine that checks the HP-IB Command Library error status. Define the types of variables passed to this routine: `error_no` is the error value, `routine` is the HP-IB Command Library routine called.

Line 720 Define a variable to hold the keypress.

Line 740 Test if an error actually occurred.

Line 760 Yes, one did. Print on the computer CRT which HP-IB Command Library routine the error occurred in.

Line 770 Print on the computer CRT the error number and a message.

Line 780 Print a prompt on the computer CRT.

Line 790 Wait for a keypress, then continue.

Line 800 Since an error occurred, halt program execution.

Line 820 The end of `error_handler()`.

Running program 9

1. Clear the computer CRT and type in the program.
2. Press [ALT] [R] [G] on the computer.
3. After the analyzer and source are preset, the CRT will be blanked. First a grid is plotted on the CRT. While this isn't necessary for our connection diagram, it does give you a good indication of where the X and Y coordinates are on the analyzers' CRT.
4. The labeling is added. The labels "CONNECTION DIAGRAM" and "DUT" are done using the analyzer CRT's internal character set.
5. All of the lines are plotted on the analyzer's CRT. If brighter lines are desired, draw each line twice or, select a different pen number.

In this example, only graphics page 1 was used. You can independently control up to 7 separate pages of graphics information. If you write too much information into one page, it overflows onto the next page.

When a graphics page is selected, the first location of memory that receives information is reset to the beginning of the page. Thus, as information is written into the page, the old information is destroyed. If we were plotting a line, this would appear as a new trace overwriting an old one.

Program 10: learning the instrument state

Being able to save a specific instrument state is helpful when it is needed several times in a test or measurement procedure. You can save the instrument state by manually logging the important analyzer and source parameters, such as start/stop frequency, sweep time, number of trace points, scale per division, and display format, then replace them at the appropriate time. A simpler approach is to save the instrument state in one of the nine internal save/recall registers of the analyzer/source combination, then recall it when needed.

The HP-IB user has two additional options: the interrogate function and the learn string. With the output interrogated parameter function (OP), you can selectively interrogate the values of all functions that have numeric values (such as frequency and number of trace points). This function operates the same way in both the analyzer and the source. It is illustrated in program 3 where the source start and stop frequencies are interrogated in lines 330 through 400.

A more thorough approach is to use the learn string functions of the analyzer and source. The learn string describes the present instrument state and is similar to one of the internal save/recall registers. For the analyzer, the Learn String also includes all of the global parameters, but not limit line information. Once an instrument state is learned, the analyzer and source states can be restored at any time. The following program demonstrates how to learn and restore the instrument states of the analyzer and HP 8350B Sweeper by using their learn string functions. If using the HP 8340B, 8341B, or 8360 Series Synthesized Sweepers, perform the modification described at the end of "Running program 10." If using an HP 8757E, note the program changes to lines 160 and 210 under Program 10 explanation.

Program 10 listing

```

10: /* HP8757D/E QuickC IPG Program10 */
20:
30: #include <string.h>
40: #include <graph.h>
50: #include <stdio.h>
60: #include <func.h>
70: #include <hpib.h>
80:
90: int IOOUTPUTS_CHK (long hpib_adr, char
    *cmd_str);
100: void error_handler (int error_no, char
    *routine);
110:
120: main ()
130: {
140:     char    ch, match,
150:            cmd [160],
160:            lsna [301], lswpr [91];
170:     long    isc =7,
180:            sna =716,
190:            passthru =717;
200:     int     error, elements,
210:            maxsna =300,
220:            maxswpr =90;
230:
240:     match =10; /* if */
250:     _clearscreen (_GCLEARSCREEN);

```

```

260:
270:     error = IOTIMEOUT (isc,10.0);
280:     error_handler (error, "IOTIMEOUT");
290:     error = IOABORT (isc);
300:     error_handler (error, "IOABORT");
310:     error = IOCLEAR (isc);
320:     error_handler (error, "IOCLEAR");
330:
340:     error = IOOUTPUTS_CHK (sna, "IP");
350:     error = IOOUTPUTS_CHK (sna, "PT19");
360:     error = IOLOCAL (sna);
370:     error_handler (error, "IOLOCAL");
380:     printf ("Set up system, Press
    <ENTER>\n");
390:     ch = getche ();
400:
410:     error = IOOUTPUTS_CHK (sna, "OL");
420:     error = IOMATCH (isc, match, 0);
430:     error_handler (error, "IOMATCH");
440:     elements = maxsna;
450:     error = IOENTERS (sna, lsna, &elements);
460:     error_handler (error, "IOENTERS");
470:     error = IOOUTPUTS_CHK (passthru, "OL");
480:     elements = maxswpr;
490:     error = IOENTERS (passthru, lswpr,
    &elements);
500:     error_handler (error, "IOENTERS");
510:     error = IOMATCH (isc, match,1);
520:     error_handler (error, "IOMATCH");
530:     error = IOOUTPUTS_CHK (sna, "IP");
540:     printf ("To restore system, Press
    <ENTER>\n");
550:     ch = getche ();
560:
570:     elements = maxsna +2;
580:     strcpy (cmd, "IL");
590:     memcpy (&cmd[2], lsna, maxsna);
600:     error = IOOUTPUTS (sna, cmd, elements);
610:     error_handler (error, "IOOUTPUTS");
620:     elements = maxswpr +2;
630:     strcpy (cmd, "IL");
640:     memcpy (&cmd[2], lswpr, maxswpr);
650:     error = IOOUTPUTS (passthru, cmd,
    elements);
660:     error_handler (error, "IOOUTPUTS");
670:     error = IOCLEAR (sna);
680:     error_handler (error, "IOCLEAR");
690:     error = IOLOCAL (sna);
700:     error_handler (error, "IOLOCAL");
710: }
720:
730: int IOOUTPUTS_CHK (long hpib_adr, char
    *cmd_str)
740: {
750:     int    length, error_no;
760:
770:     length = strlen (cmd_str);
780:     error_no = IOOUTPUTS (hpib_adr,
    cmd_str, length);
790:     error_handler (error_no,
    "IOOUTPUTS_CHK");
800:     return error_no;
810: }
820:
830: void error_handler (int error_no, char
    *routine)
840: {
850:     char    ch;
860:
870:     if (error_no != NOERR)
880:     {
890:         printf ("Error in call to %s \n",
    routine);
900:         printf ("      Error = %d : %s \n",
    error_no, errstr (error_no));
910:         printf ("Press <ENTER> to
    continue\n");
920:         ch = getche ();
930:         exit (1);
940:     }
950: }

```

Program 10 explanation

- Line 30 Tell the compiler which file includes information on string functions.
- Line 40 Tell the compiler which file includes information on `_clearscreen()` and `_settextposition()`.
- Line 50 Tell the compiler which file includes information on `printf()`.
- Line 60 Tell the compiler which file includes information on the HP-IB Command Library I/O functions.
- Line 70 Tell the compiler which file includes information on the HP-IB Command Library error constants and `errstr()`.
- Line 90 Function prototype for the `IOOUTPUTS_CHK()` routine.
- Line 100 Function prototype for the `error_handler()` routine.
- Line 120 Define the beginning of the `main()` routine.
- Line 140 Define variables to hold the keypress and the HP-IB Command Library match character.
- Line 150 Define a string variable for the output commands.
- Line 160 Define string variables for the analyzer and source learn strings. Make sure the dimensioned length is one more than the number of bytes in the learn string to retain the end-of-string null character (decimal 0). If using an HP 8757E, change `lsna [301]` to `lsna [151]`.
- Line 170 Define a variable and assign it a value for the interface select code.
- Line 180 Define a variable and assign it a value for the HP-IB address of the analyzer.
- Line 190 Define a variable and assign it a value for the analyzer's passthru address.
- Line 200 Define variables for the HP-IB Command Library error status and the number of elements in an array.
- Line 210 Define a variable and assign it a value for the maximum number of characters in the analyzer learn string. If using an HP 8757E, change `maxsna = 300` to `maxsna = 150`.
- Line 220 Define a variable and assign it a value for the maximum number of characters in the source learn string.
- Line 240 Define the HP-IB Command Library match character as a linefeed.
- Line 250 Clear the computer CRT.
- Line 270 Define a system timeout of 10 seconds.
- Line 280 Perform error trapping.
- Line 290 Abort any HP-IB transfers.
- Line 300 Perform error trapping.
- Line 310 Clear the analyzer's HP-IB interface.
- Line 320 Perform error trapping.
- Line 340 Preset the analyzer and the source.
- Line 350 Tell the analyzer which device is controlled through the passthru address. Address 19 belongs to the source.
- Line 360 Set the analyzer and source to local mode.
- Line 370 Perform error trapping.
- Line 380 Prompt the user to set up the system.
- Line 390 Wait until [ENTER] is pressed to continue.
- Line 410 Program the analyzer to output its learn string.
- Line 420 Disable character matching for the linefeed. The analyzer learn string is 300 contiguous binary bytes (150 for the HP 8757E) that does not end with a `cr/lf` (since this could actually be part of the learn string information).
- Line 430 Perform error trapping.
- Line 440 Determine the number of elements to be read.
- Line 450 Read the analyzer learn string into the string "lsna".
- Line 460 Perform error trapping.
- Line 470 Program the source to output its learn string.
- Line 480 Determine the number of elements to be read.
- Line 490 Read the source learn string into the string "lswpr". The computer must read the entire source learn string which, for the HP 8350B Sweeper, is 90 bytes long.
- Line 500 Perform error trapping.
- Line 510 Enable character matching; this results in termination on a linefeed when a string is read.

- Line 520 Perform error trapping.
- Line 530 Preset the analyzer and source to clear the instrument states.
- Line 540 Prompt the user to restore the system.
- Line 550 Wait until [ENTER] is pressed to continue.
- Line 570 Determine the number of elements to be sent (add 2 for the "IL" prefix).
- Line 580 Start the learn string with the "IL" command.
- Line 590 Concatenate the analyzer's binary learn string to the "IL" command. Remember that cmd[2] is the third element in this string (cmd[0] is the first). Since the learn string may contain nulls (decimal 0), "strcpy" cannot be used as it will stop at the first null. "memcpy" does not have this limitation.
- Line 600 Program the analyzer to accept its learn string, then send it. Because "strlen" has the same problems as "strcpy", you cannot use the IOOUTPUTS_CHK routine here.
- Line 610 Perform error trapping.
- Line 620 Determine the number of elements to be sent (add 2 for the "IL" prefix).
- Line 630 Start the learn string with the "IL" command.
- Line 640 Concatenate the source's binary learn string to the "IL" command. Remember that cmd[2] is the third element in this string (cmd[0] is the first). Since the learn string may contain nulls (decimal 0), "strcpy" cannot be used as it will stop at the first null. "memcpy" does not have this limitation.
- Line 650 Program the source to accept its learn string, then send it. Because "strlen" has the same problems as "strcpy", you cannot use the IOOUTPUTS_CHK routine here.
- Line 660 Perform error trapping.
- Line 670 Exit passthru mode by clearing the analyzer's HP-IB interface and continue sweeping.
- Line 680 Perform error trapping.
- Line 690 Set the analyzer and source to local mode.
- Line 700 Perform error trapping.
- Line 710 The end of main().
- Line 730 Define a routine that outputs string commands and performs error trapping. Define the types of variables passed to this routine: hpib_adr is the HP-IB address, cmd_str is the command string to output.
- Line 750 Define variables for the length of the string and the error status.
- Line 770 Determine the length of the command string.
- Line 780 Output the command string.
- Line 790 Perform error trapping.
- Line 800 Return the error status as the value of the routine.
- Line 810 The end of IOOUTPUTS_CHK().
- Line 830 Define a routine that checks the HP-IB Command Library error status. Define the types of variables passed to this routine: error_no is the error value, routine is the HP-IB Command Library routine called.
- Line 850 Define a variable to hold the keypress.
- Line 870 Test if an error actually occurred.
- Line 890 Yes, one did. Print on the computer CRT which HP-IB Command Library routine the error occurred in.
- Line 900 Print on the computer CRT the error number and a message.
- Line 910 Print a prompt on the computer CRT.
- Line 920 Wait for a keypress, then continue.
- Line 930 Since an error occurred, halt program execution.
- Line 950 The end of error_handler().

Running program 10

1. Clear the computer CRT and type in the program.
2. Press [ALT] [R] [G] on the computer.
3. When the computer stops and displays:

```
SET UP SYSTEM, PRESS <ENTER>
```

Adjust the analyzer and source to a preferred instrument state and press [ENTER] on the computer.
4. The computer will save the learn strings of both the analyzer and the source. After completing this, the analyzer and source will be preset to destroy your original instrument state.

5. When the computer stops and displays:

TO RESTORE SETUP, PRESS <ENTER>

Press the [ENTER] key. The computer will restore your original instrument state via the two learn strings. Verify on the displays of the analyzer and the source that your state has been restored.

This example is designed to work with the HP 8350B Sweeper, which has a learn string of 90 bytes. The program can be easily modified to work with the HP 8340B and 8341B Synthesized Sweepers which have learn strings 123 bytes in length. To do this, change the following lines to be:

```
160: lsna [301], lswpr [124];
220: maxswpr =123;
```

To work with the HP 8360 Series Synthesized Sweeper, the modifications are more extensive due to its variable length learn string. To do this, change and/or add the following lines:

```
150:          cmd [701],
160:          lsna [301], lswpr [701];
161: unsigned  char  lswpr0 [4];
220:          maxswpr = 700;
471: elements = 3;
472: error = IOENTERS (passthru, lswpr0,
&elements);
473: error_handler (error, "IOENTERS");
474: maxswpr = 256 * lswpr0 [1] + lswpr0 [2];
620: elements = maxswpr + 5;
631: memcpy (&cmd[2], lswpr0, 3);
640: memcpy (&cmd[5], lswpr, maxswpr);
```

The following should explain the above actions:

- Line 150 Define a string variable large enough to hold the HP 8360 learn string.
- Line 160 Define another string variable large enough to hold the HP 8360 learn string. Presently, the HP 8360 learn string is 605 bytes long but allow for some potential growth.
- Line 161 Define a string variable to hold the header portion of the HP 8360 learn string (3 bytes). Make it an unsigned char array so that the value of each character ranges from 0 to 255 decimal (vs. -128 to +127).
- Line 472 Read the 3 header bytes. Bytes 2 and 3 indicate the number of bytes to follow.
- Line 473 Perform error trapping.
- Line 474 Compute the number of bytes to follow (for the remainder of the HP 8360 learn string) and change maxswpr to reflect this.
- Line 620 Determine the number of elements to be sent (add 2 for the "IL" prefix and 3 for the header bytes).

Line 631 Concatenate the HP 8360 header bytes to the "IL" command. Remember that cmd[2] is the third element in this string (cmd[0] is the first). Since the learn string may contain nulls (decimal 0), "strcpy" cannot be used as it will stop at the first null. "memcpy" does not have this limitation.

Line 640 Concatenate the remainder of the HP 8360 learn string. Remember that cmd[5] is the sixth element in this string.

Program 11: guided instrument setup with CRT graphics

As was illustrated by program 9, it is possible to utilize the CRT of the HP 8757D/E as a plotter. This program goes one step further by utilizing the CRT to create a simple connection diagram which may be recalled by the user, at any time, from the front panel of the analyzer.

This program draws the same hypothetical connection diagram as was drawn by program 9. It will blank most of the analyzer's standard display including the graticule and all annotation except the softkeys. In addition it will add one softkey under both the save and the recall hardkey menus. This softkey will allow the user to toggle the state of the CRT graphics off and on.

To use the graphics off/on capability of the HP 8757D/E, change "BL5" in line 310 of program 9 to "BLA", and make the necessary changes in the size of the background grid. These and other changes are illustrated in the following listing.

The same principle can be used to save anything stored to disk on the HP 8757D in the first seven pages of user graphics. By having the softkeys available, the user can store CRT graphics onto a disk for later recall.

Program 11 listing

```
10: /* HP8757D/E QuickC IPG Program11 */
20:
30: #include <string.h>
40: #include <graph.h>
50: #include <stdio.h>
60: #include <cfunc.h>
70: #include <chplib.h>
80:
90: int IOOUTPUTS_CHK (long hpib_adr, char
*cmd_str);
100: void error_handler (int error_no, char
*routine);
110:
120: main ()
130: {
140:   char  cmd [80];
150:   long  isc =7,
160:         sna =716,
170:         passthru =717;
180:   int   error, col, row;
190:
200:   _clearscreen (_GCLEARSCREEN);
210:
```

```

220: error = IOTIMEOUT (isc,10.0);
230: error_handler (error, "IOTIMEOUT");
240: error = IOABORT (isc);
250: error_handler (error, "IOABORT");
260: error = IOCLEAR (isc);
270: error_handler (error, "IOCLEAR");
280:
290: error = IOOUTPUTS_CHK (sna, "IP BLA
PT15;");
300: error = IOOUTPUTS_CHK (passthru,
"EP;GP1,1;DEC;");
310: error = IOOUTPUTS_CHK (passthru, "SP6;");
320:
330: for (col = 0; col <=25; col = col +1)
340: {
350:     sprintf (cmd, "PU;PA%d,0;PD;
PA%d,2000;", col * 100, col *100);
360:     error = IOOUTPUTS_CHK (passthru, cmd);
370: }
380: for (row = 0; row <=20; row = row +1)
390: {
400:     sprintf (cmd, "PU;PA 0,%d;PD;PA
2500,%d;", row *100, row *100);
410:     error = IOOUTPUTS_CHK (passthru,cmd);
420: }
430: error = IOOUTPUTS_CHK (passthru, "SP8");
440: error = IOOUTPUTS_CHK (passthru, "PU;PA
600,1600;PD");
450: error = IOOUTPUTS_CHK (passthru,
"SI0.28,0.34; LBCONNECTION DIAGRAM\3");
460: error = IOOUTPUTS_CHK (passthru, "PU;PA
1200,250;PD");
470: error = IOOUTPUTS_CHK (passthru,
"SI0.28,0.34;LBDUT\3");
480: error = IOOUTPUTS_CHK (passthru, "PU;PA
300,800;PD;PA 1100,800,1100,1100,300,1100,
300,800");
490: error = IOOUTPUTS_CHK (passthru, "PU;PA
800,800;PD;PA800,1100");
500: error = IOOUTPUTS_CHK (passthru, "PU;PA
1500,800;PD;PA 2300,800,2300,1200,1500,
1200,1500,800");
510: error = IOOUTPUTS_CHK (passthru, "PU;PA
1950,800;PD;PA1950,1200");
520: error = IOOUTPUTS_CHK (passthru, "PU;PA
875,850;PD;PA875,500,1200,500");
530: error = IOOUTPUTS_CHK (passthru, "PU;PA
1400,500;PD;PA2050,500,2050,850");
540: error = IOOUTPUTS_CHK (passthru, "PU;PA
1200,400;PD;PA 1400,500,1200,600,1200,400");
550: error = IOOUTPUTS_CHK (passthru, "PU;PA
0,0");
560: error = IOCLEAR (sna);
570: error_handler (error, "IOCLEAR");
580:
590: error = IOLOCAL (sna);
600: error_handler (error, "IOLOCAL");
610: }
620:
630: int IOOUTPUTS_CHK (long hpib_adr, char
*cmd_str)
640: {
650:     int length, error_no;
660:
670:     length = strlen (cmd_str);
680:     error_no = IOOUTPUTS_ (hpib_adr,
cmd_str, length);
690:     error_handler (error_no,
"IOOUTPUTS_CHK");
700:     return error_no;
710: }
720:
730: void error_handler (int error_no, char
*routine)
740: {
750:     char ch;
760:
770:     if (error_no != NOERR)
780:     {
790:         printf ("Error in call to %s \n",
routine);
800:         printf ("      Error = %d ; %s \n",
error_no, errstr (error_no));
810:         printf ("Press <ENTER> to
continue\n");
820:         ch = getche ();
830:         exit (1);
840:     }
850: }

```

Program 11 explanation

- Line 30 Tell the compiler which file includes information on string functions.
- Line 40 Tell the compiler which file includes information on `_clearscreen()` and `_setttextposition()`.
- Line 50 Tell the compiler which file includes information on `printf()`.
- Line 60 Tell the compiler which file includes information on the HP-IB Command Library I/O functions.
- Line 70 Tell the compiler which file includes information on the HP-IB Command Library error constants and `errstr()`.
- Line 90 Function prototype for the `IOOUTPUTS_CHK()` routine.
- Line 100 Function prototype for the `error_handler()` routine.
- Line 120 Define the beginning of the `main()` routine.
- Line 140 Define a string variable for the output commands.
- Line 150 Define a variable and assign it a value for the interface select code.
- Line 160 Define a variable and assign it a value for the HP-IB address of the analyzer.
- Line 170 Define a variable and assign it a value for the analyzer's passthru address.
- Line 180 Define variables for the HP-IB Command Library error status, CRT column and row.
- Line 200 Clear the computer CRT.
- Line 220 Define a system timeout of 10 seconds.
- Line 230 Perform error trapping.
- Line 240 Abort any HP-IB transfers.
- Line 250 Perform error trapping.
- Line 260 Clear the analyzer's HP-IB interface.
- Line 270 Perform error trapping.
- Line 290 Preset the analyzer and blank all the CRT display except the softkeys. Define the CRT graphics as the target of passthru commands. The CRT graphics address is always one less than the analyzer's HP-IB address.
- Line 300 Erase all graphics pages. Turn graphics page 1 on to ensure that the graphics start in it. Set the color selection to default colors.

Line 310	Select to plot with pen 6 (white), the lowest intensity for the analyzer CRT.	Line 570	Perform error trapping.
Line 330	Loop 26 times to draw the vertical part of the grid.	Line 590	Place the analyzer and the source in local mode.
Line 350	Create a formatted output by printing the HP-GL plotter commands to a string.	Line 600	Perform error trapping.
Line 360	Draw a vertical line down the CRT.	Line 610	The end of main().
Line 370	End of the loop.	Line 630	Define a routine that outputs string commands and performs error trapping. Define the types of variables passed to this routine: hpib_adr is the HP-IB address, cmd_str is the command string to output.
Line 380	Loop 21 times to draw the horizontal part of the grid.	Line 650	Define variables for the length of the string and the error status.
Line 400	Create a formatted output by printing the HP-GL plotter commands to a string.	Line 670	Determine the length of the command string.
Line 410	Draw a horizontal line across the CRT.	Line 680	Output the command string.
Line 420	End of the loop.	Line 690	Perform error trapping.
Line 430	Select to plot with pen 8 (yellow), the brightest intensity for the analyzer CRT.	Line 700	Return the error status as the value of the routine.
Line 440	Move the pen to title the display.	Line 710	The end of IOOUTPUTS_CHK().
Line 450	Specify the width and height of each character, indicate what the title is, terminate the title with an end-of-text character (decimal 3).	Line 730	Define a routine that checks the HP-IB Command Library error status. Define the types of variables passed to this routine: error_no is the error value, routine is the HP-IB Command Library routine called.
Line 460	Move the pen to label the DUT.	Line 750	Define a variable to hold the keypress.
Line 470	Specify the width and height of each character, indicate what the title is, terminate the title with an end-of-text character (decimal 3).	Line 770	Test if an error actually occurred.
Line 480	Move the pen and draw the outline of the source.	Line 790	Yes, one did. Print on the computer CRT which HP-IB Command Library routine the error occurred in.
Line 490	Draw the plug-in of the source.	Line 800	Print on the computer CRT the error number and a message.
Line 500	Move the pen and draw the outline of the analyzer.	Line 810	Print a prompt on the computer CRT.
Line 510	Draw the CRT of the analyzer.	Line 820	Wait for a keypress, then continue.
Line 520	Draw the connections from the source to the DUT.	Line 830	Since an error occurred, halt program execution.
Line 530	Draw the connections from the DUT to the analyzer.	Line 850	The end of error_handler().
Line 540	Draw the DUT (an amplifier).		
Line 550	Move to the bottom left corner of the CRT.		
Line 560	Exit passthru mode by clearing the analyzer's HP-IB interface.		

Running program 11

1. Clear the computer CRT and type in the program.
2. Press [ALT] [R] [G] on the computer.
3. After the analyzer and source are preset, the CRT is blanked, except for softkeys. First a grid is plotted on the CRT. While this isn't necessary for our connection diagram, it does give you a good indication of where the X and Y coordinates are on the analyzers' CRT.
4. The labeling is added. The labels "CONNECTION DIAGRAM" and "DUT" are written using the analyzer CRT's internal character set.
5. All of the lines are plotted on the analyzer's CRT. If brighter lines are desired, draw each line twice or, select different pen numbers.
6. The analyzer is placed in local mode with the front panel and the softkeys active. To access the graphics on/off capability, press [SAVE] on the analyzer to show the save menu. Press the softkey labeled [STORE TO DISK]. Note the [GRAPHIC ON/OFF] softkey, it does not appear unless the "BLA" command is used. Press the [GRAPHIC ON/OFF] softkey so that it is "off". The connection diagram will disappear from the CRT display. Press the [GRAPHIC ON/OFF] softkey again and the diagram will reappear. If you store this setup to the external disk drive at this time, the analyzer will remember this graphics on/off mode later upon recall from disk.

Table 2. Alphabetical Listing of HP 8757D/E Programming Codes (1 of 3)

Code	Action	Code	Action
A0	Averaging off	CLS	Color list, salmon ¹
AB	A/B ratio measurement	CLW	Color list, white ¹
AC	A/C ratio measurement ²	CLY	Color list, yellow ¹
AFd	Averaging on and factor d	CN	Cursor to minimum
ANm	Adaptive Normalization on/off	COBd	Brightness adjust, one color ¹
AR	A/R ratio measurement	COCd	Color adjust, one color ¹
AS	Autoscale	COTd	Tint adjust, one color ¹
AZ2	Autozero the DC detectors once	CR	C/R ratio measurement ²
AZm	Autozero repeat on/off of the DC detectors	CS	Clear status bytes
BA	B/A ratio measurement	CTm	Auto system calibration on/off
BC	B/C ratio measurement ²	CUm	Cursor on/off
BFm	Plotter buffer on/off ³	CWm	CW mode on/off
BL0	Restore CRT to normal mode	CX	Cursor to maximum
BL1	Blank frequency labels (secure frequency mode, frequency labels cannot be restored)	DAd	Detector A amplitude offset set to d
BL2	Blank all labels	DBd	Detector B amplitude offset set to d
BL3	Blank active channel trace	DCd	Detector C amplitude offset set to d ²
BL4	Blank softkey labels	DEC	Set default colors ¹
BL5	Blank all (except user CRT graphics)	DFA	Set disk format to ASCII ¹
BL6	Blank title	DFB	Set disk format to binary ¹
BL7	Blank mode labels	DFE	Set Disk format to extended binary ¹
BL8	Blank the active entry area	DHm	Display Hold on/off of the active channel trace
BL9	Blank the limit lines	DIAd	Set disk HP-IB address ¹
BLA	Blank all (except user CRT graphics and softkeys)	DIUd	Set disk unit number ¹
BR	B/R ratio measurement	DIVd	Set disk volume number ¹
BTNd	Overall display brightness	DLF	Delete file from disk ¹
BW	Display the search bandwidth on the CRT ¹	DM0	All inputs set to DC detection
C0	Channel off	DM1	All inputs set to AC detection
C1	Channel 1 on/active	DN	Step down (decrement)
C2	Channel 2 on/active	DOAd	Measure Detector A amplitude offset
C3	Channel 3 on/active ¹	DOBd	Measure Detector B amplitude offset
C4	Channel 4 on/active ¹	DOCd	Measure Detector C amplitude offset ²
CA	C/A ratio measurement ²	DORd	Measure Detector R amplitude offset
CB	C/B ratio measurement ²	DRd	Detector R amplitude offset set to d
CC1	Set channel 1 color ¹	DS0	Display trace data in log magnitude
CC2	Set channel 2 color ¹	DS1	Display trace data in standing wave ratio (SWR) format
CC3	Set channel 3 color ¹	DTSTPAs	Enter stop frequency for detector A
CC4	Set channel 4 color ¹	DTSTPBs	Enter stop frequency for detector B
CDm	Cursor delta on/off	DTSTPCs	Enter stop frequency for detector C ²
CGL	Set labels color ¹	DTSTPRs	Enter stop frequency for detector R
CGN	Set background color ¹	DTSTRAs	Enter start frequency for detector A
CGR	Set grid color ¹	DTSTRBs	Enter start frequency for detector B
CGW	Set warning label color ¹	DTSTRCs	Enter start frequency for detector C ²
CL	Perform system configuration of detectors and channels	DTSTRRs	Enter start frequency for detector R
CLB	Color list, black ¹	EO	Enter measured detector amplitude offset
CLG	Color list, green ¹	ER0	Erase all save/recall registers
CLL	Color list, blue ¹	FAs	Start frequency label
CLR	Color list, red ¹	FBs	Stop frequency label
		FD0	Format data ASCII

1. HP 8757D only

2. HP 8757D Option 001 only

3. Revision 3.1 or above for HP 8757E.

Table 2. Alphabetical Listing of HP 8757D/E Programming Codes (2 of 3)

Code	Action	Code	Action
FD1	Format data binary (HP BASIC compatible)	MU3	Display the reference menu
FD2	Format data extended ASCII	MU4	Display the cursor menu
FD3	Format data binary (PC compatible)	MU5	Display the average menu
FD4	Format data extended binary (HP BASIC compatible)	MU6	Display the calibration menu
FD5	Format data extended binary (PC compatible)	MU7	Display the special menu
FR0	Logarithmic (dB) cursor format ³	MU8	Display the system menu
FR1	SWR cursor format ³	MY	Display memory data
FSm	Step sweep on/off ^{3,4}	MZ	Manual calibration of DC detectors
FTAm	Detector A frequency on/off	NSm	Non-standard sweep mode on/off
FTBm	Detector B frequency on/off	OC	Output cursor value
FTCm	Detector C frequency on/off ²	OD	Output trace data
FTRm	Detector R frequency on/off	OE1	Output error status of display channel 1
IA	Input A absolute power measurement	OE2	Output error status of display channel 2
IB	Input B absolute power measurement	OI	Output identity
IC	Input C absolute power measurement ²	OK	Output keycode of last key pressed
ILs	Input Learn string	OL	Output learn string
IND	Initialize disk format ¹	OM	Output memory data
IP	Instrument preset	ON	Output normalized (measurement —memory) data
IR	Input R absolute power measurement	OPDO	Output measured detector amplitude offset
IX	External ADC input (AUX) voltage measurement ¹	OPxx	Output interrogated parameter value xx= AF, BW, DA, DB, DC, DR, RL, RP, SD, SL, SO, SP, SR, SS, ST
LE	Erase limit lines for active channel ⁵	OR	Output rotary knob value (−32768 ≤ value ≤ +32767)
LFA	Load instrument information file from disk ¹	OS	Output status bytes
LFC	Load CRT graphics file from disk ¹	OT1m	Control output #1 on/off
LFD	Load data trace file from disk ¹	OT2m	Control output #2 on/off
LFF	Load measurement file from disk. ¹	OV	Output CW value
LFH	Load instrument information file from disk and place instrument in hold mode. ¹	P1	Plot channel 1 trace on external plotter
LFI	Load instrument state file from disk ¹	P2	Plot channel 2 trace on external plotter
LFM	Load memory trace file from disk ¹	P3	Plot channel 3 trace on external plotter ¹
LFN	Load display trace file from disk. ¹	P4	Plot channel 4 trace on external plotter ¹
LFs	Enter limit test flat line data ⁵	PA	Plot all on external plotter
LL	Store lower limit line into memory ⁵	PBm	System interface control on/off
LPs	Enter limit test point data ⁵	PC	Plot labels on external plotter
LSs	Enter limit test sloped line data ⁵	PD	Plot custom plot
LIm	Limit line test on/off ⁵	PG	Plot grid on external plotter
LU	Store upper limit line into memory ⁵	PR1	Print all to monochrome printer, except softkeys and CRT graphics
M-	Display normalized data (measurement — memory)	PR2	Print tabular display data in monochrome
MDm	Modulation on/off	PR3	Print tabular marker/cursor data to external printer
ME	Display measurement data	PR4	Print all to color printer, except softkeys and CRT graphics ¹
MM	Display the channel menu(main menu)	PTd	Passthrough address set to d
MN	Display normalized data (same as M-)	PWRA	Execute a detector A power calibration
MOC	Monochrome display ¹	PWRB	Execute a detector B power calibration
MR	Marker (or cursor) to reference line	PWRC	Execute a detector C power calibration ²
MSm	Manual sweep mode on/off	PWRR	Execute a detector R power calibration
MU0	Display the measurement menu	R1	R/A ratio measurement
MU1	Display the display menu	R2	R/B ratio measurement
MU2	Display the scale menu		

1. HP 8757D only

2. HP 8757D Option 001 only

3. Revision 3.1 or above for HP 8757E.

4. HP 8340, HP 8341, or HP 8360 series synthesized sweeper only with 8757 SYSTEM INTER-FACE connected and active.

5. Limit line functions valid only for channels 1 or 2. HP 8757D only.

Table 2. Alphabetical Listing of HP 8757D/E Programming Codes (3 of 3)

Code	Action	Code	Action
R3	R/C ratio measurement ²	SR	Cursor search right ¹
RCn	Recall register n	SSd	Cursor search value set to d ¹
RLd	Reference level set to d	STd	Reference level step size set to d
RMd	Service request mask set to d	SUd	Specify custom plot according to d
RPq	Reference position set to vertical division q	SVn	Save register n
RS	Restart averaging	SW0	Non-swept mode; non-swept operation
SCd	Set cursor to horizontal position d	SW1	Swept mode; normal swept operation
SDd	Scale per division set to d	SW2	Sweep hold mode; non-swept mode with HP-IB bus hold off until completion of TSd
SFA	Store all instrument information to disk in file ¹	TCm	Continuous Temperature Compensation on/off
SFC	Store CRT graphics to disk in file ¹	TIFs	Title for file ¹
SFD	Store data trace to disk in file ¹	TSd	Take d sweeps, then hold display
SFI	Store instrument state to disk in file ¹	UP	Step up (increment)
SFM	Store memory trace to disk in file ¹	WKs	Write softkey label
SFN	Store normalized trace to disk in file ¹	WMs	Write to channel memory.
SKq	Select softkey q: q = 1 to 8	WTs	Write title, s is an ASCII string of up to 50 characters
SL	Cursor search left ¹	XAs	External detector cal value for detector A
SM	Store measurement into memory	XBs	External detector cal value for detector B
SN	Store normalized data (measurement - memory) into memory	XC ^s	External detector cal value for detector C ²
SOd	Smoothing set to d % of frequency span	XR ^s	External detector cal value for detector R
SPd	Number of points set to d: d=101, 201, 401, 801 ¹ , 1601 ¹		

1. HP 8757D only

2. HP 8757D Option 001 only (detector C)

NOTES: n = decimal integer 1 to 9
d = variable length numeric
m = 0 for off/1 for on
q = unique value
s = ASCII or binary string

For more information, call your local HP sales office listed in your telephone directory or an HP regional office listed below for the location of your nearest sales office.

United States:

Hewlett-Packard Company
4 Choke Cherry Road
Rockville, MD 20850
(301) 670-4300

Hewlett-Packard Company
5201 Tollview Drive
Rolling Meadows, IL 60008
(312) 255-9800

Hewlett-Packard Company
5161 Lankershim Blvd.
No. Hollywood, CA 91601
(818) 505-5600

Hewlett-Packard Company
2015 South Park Place
Atlanta, GA 30339
(404) 955-1500

Canada:

Hewlett-Packard Ltd.
6877 Goreway Drive
Mississauga, Ontario L4V1M8
(416) 678-9430

Australia/New Zealand:

Hewlett-Packard Australia Ltd.
31-41 Joseph Street,
Blackburn, Victoria 3130
Melbourne, Australia
(03) 895-2895

Europe/Africa/Middle East:

Hewlett-Packard S.A.
Central Mailing Department,
P.O. Box 529
1180 AM Amstelveen,
The Netherlands
(31) 20/547 9999

Far East:

Hewlett-Packard Asia Ltd.
22/F Bond Centre
West Tower
89 Queensway
Central, Hong Kong
(5) 8487777

Japan:

Yokogawa-Hewlett-Packard Ltd.
29-21, Takaido-Higashi 3-chome
Suginami-ku, Tokyo 168
(03) 331-6111

Latin America:

Latin American Region Headquarters
Monte Pelvoux Nbr. 111
Lomas de Chapultepec
11000 Mexico, D.F. Mexico
(905) 596-79-33

July 15, 1992

HP Part Number 08757-90118

Printed in U.S.A.



In Case of Difficulty

Use the suggestions in this section if you have a minor problem with the analyzer (such as cable connections, or manual, system, or remote operation) that does not involve internal circuitry. If you need more information, refer to the service manual.

- Contents**
- Manual Operation
 - Line Power
 - Error Codes
 - System Operation
 - General
 - HP-IB Connections and Addresses
 - Other Cable Connections
 - Remote Operation
 - Inaccurate Operation
 - Calibration
 - Modulation Characteristics
 - Sweep Speed
 - Miscellaneous Problems
 - Alternate Sweep
 - Number of Trace Points and Trace Memory
 - Autozero of DC Detectors
 - Save/Recall Registers
 - System Interface On/Off
 - Measurement – Memory → Memory
 - Cursor Search
 - On-Site Service Repairs
 - Notes on Equipment Required
 - Notes on Re-Calibration
 - Main Error Codes
 - Instrument Verify
 - Other Tests:
 - EEPROM write enabled
 - Other Problems:
 - Power Calibration Error Messages
 - On-site Service-Calibration

Manual Operation

Line Power With the power switch turned on, if all front panel LEDs remain off and the fan does not operate, suspect a power problem.

- Is the power line cable is properly connected?
- Is the correct line voltage selected at the rear panel power line module? See chapter 2 for installation instructions.
- Is the correct fuse installed in the line module fuse holder (see chapter 2 for the proper fuse rating for each line voltage)?

Error Codes When you press the front panel **PRESET** key, the analyzer performs a series of self-tests before establishing the preset conditions. If any of these tests fail, the analyzer displays an error code from 1 through 15 (in binary form) with lighted LEDs both on the front panel (the LEDs labeled R, L, T, and S in the INSTRUMENT STATE HP-IB STATUS area), and on the A3 CPU assembly (four of the eight LEDs near the top left corner of the board). In many cases, an error message also appears on the CRT. Because the front panel LEDs do not light in the event of a front panel failure, the best failure indicators are the LEDs on the CPU assembly. Table 1-1 lists the main error codes and most probable cause of failure. If you encounter an error message, refer to the service manual for troubleshooting (some additional information is provided under "On-Site Service".)

Table 1-1. Summary of Error Codes

LED Reading 8-4-2-1	Error Code	Test Description and Explanation	Probable Cause of Failure
1-1-1-1	15	Microprocessor kernel	A3
1-1-1-0	14	ROM checksum	A3
1-1-0-1	13	RAM checksum	A3
1-1-0-0	12	Power supply	A12
1-0-1-1	11	Instrument bus	A3, A6
1-0-1-0	10	Display interface - GSP	A3, A14
1-0-0-1	9	Display interface - DRAM bus	A14
1-0-0-0	8	Display interface - DRAM download	A14
0-1-1-1	7	Display interface - DRAM cell	A14
0-1-1-0	6	Display interface - VRAM bus	A14
0-1-0-1	5	Display interface - VRAM cell	A14
0-1-0-0	4	Display interface - Video control	A14
0-0-1-1	3	Display interface - RGB	A14
0-0-1-0	2	Interrupt test	A2, A3, A4, A6, A14
0-0-0-1	1	Other self-test failures include: EEROM write enable Battery failure Unexpected keypress Configuration error	As indicated on CRT
0-0-0-0	0	Pretest pass	—

System Operation

When you configure the analyzer as the system controller with other instruments connected to the 8757 system interface bus, problems can occur in the configuration itself, rather than in a specific instrument.

General

- Preset each instrument (or cycle the power). In normal, operation do not preset *only* the source; this can cause a system lock-up.
- Isolate each instrument: disconnect and reconnect them one at a time from the analyzer system interface. This helps locate a problem in an instrument or its connections.
- Clean all instrument filters regularly (at least monthly). A clogged filter causes overheating and consequent degradation of performance.
- If you cannot control the system from the analyzer front panel, cycle the power with the analyzer's LINE switch.
- Check that the source is compatible with the analyzer (see chapter 1 for a list of compatible source firmware versions).

HP-IB Connections and Addresses

The system can fail if you set the instrument addresses incorrectly, or connect the HP-IB cables improperly.

- Are the HP-IB cables functional? Check for shorts, opens, and damaged connectors.
- Are that the cables for the source and other peripherals connected to the 8757 system interface connector (*not* the HP interface bus. Connect *only* a system controller to the HP interface bus).
- Is the system interface on? When off, the CRT status line displays SYS INTF OFF.
- Is the HP-IB address of each instrument set correctly?
 1. Check the *expected* address for each instrument in the system: press **LOCAL**, then select the softkey for each instrument. The CRT displays the HP-IB addresses.
 2. Check the address set at each instrument and verify that it corresponds to the expected address for that instrument displayed on the analyzer.
 3. If the addresses do not agree, either use the local menu to change the address expected by the analyzer, or reset the HP-IB address on the instrument itself.

Note



Ensure that no two instruments have the same address.

Other Cable Connections

In most applications, you must connect the analyzer STOP SWEEP, POS Z BLANK, and SWEEP OUT/IN outputs to the source (see chapter 2 for details on connecting an HP 8350, and 8340/41/60-series source). Other connections may be necessary for different applications.

Remote Operation

Most remote operation problems occur due to improper programming.

- Does all program code have the proper syntax? Are the proper number of bytes transferred when sending or requesting data to and from the analyzer?
- When you transfer binary data, ensure that an HP 9876A printer is not connected to the bus (this can prevent proper transfer).
- A printer connected to the 8757 system interface, must *not* send out an SRQ if the paper runs out (this significantly slows system performance).
- Do not set the HP-IB address of any instrument on the 8757 system interface to a value one digit greater or smaller than the analyzer's HP-IB address (this causes conflict with the analyzer's passthrough address - see "Remote Operation" for more information on passthrough addresses).

Inaccurate Operation

If the analyzer works, but you doubt the accuracy of the measurements, the problem may be with calibration or with the modulation frequency of the input signals.

Calibration

- Is the system correctly configured for the detectors connected? The system automatically reconfigures when you replace or exchange a detector. Press **CAL** and select **CONFIG SYSTEM**. The analyzer determines the types of detectors connected and calibrates each input.
- If you use DC detection, zero the detectors to compensate for the effects of DC drift (press **CAL** and select **DC DET ZERO**; choose manual or automatic zeroing).
- Enter the correct detector offset value; the status line shows which detectors have an offset entered (press **CAL** and select **DET OFFSET**; verify or change the offset values for each detector input). Remember that instrument preset will reset the offset values to zero.
- For further information on calibration procedures, refer to the Operating Reference.

Modulation Characteristics

- If you use AC detection, verify that the modulation frequency of the input signals to the detectors is 27.778 kHz \pm 20 Hz. The ON/OFF ratio must be at least 30 dB, with an ON/OFF symmetry of 50/50 \pm 5%

Sweep Speed

- If you use the 8757 system interface, the analyzer automatically limits the sweep speed. Without the system interface, you must to ensure proper sweep speed. Refer to chapter 1 "Specifications".

Calibrator Option 002 Only

- Refer to the *Service* manual for a simple accuracy test of the calibrator using only a power meter and a power splitter.

Miscellaneous Problems

The following information may clarify some analyzer features.

Alternate Sweep

The alternate sweep feature lets you simultaneously test a device over two distinct frequency ranges or power levels; in this mode, the analyzer displays the alternating sweep conditions at the same time. Use this feature, for example, to test a filter's broadband and passband characteristics simultaneously by alternating the source state between a broadband and narrowband frequency range, or test an amplifier in both its linear and compressed operating regions by alternating the source state between two power levels.

Notes



For the alternate sweep function to operate, you must connect the analyzer's system interface to the source's HP-IB interface. Also, ensure that the system interface is turned on.

You cannot save alternate state information. If you try to save alternate state, the analyzer disables the alternate sweep mode.

Using Alternate Sweep

1. Set up the analyzer for the desired measurement on channels 1 and 2 (A, B, R, A/R, B/R, and so on).
2. Turn channels 3 and 4 off.
3. Define one source state as the primary configuration and the other as the secondary (alternate) configuration. For a filter measurement, you could define a broadband sweep as the primary configuration (measured and displayed on analyzer channel 1) and a narrowband sweep as the secondary (measured and displayed on analyzer channel 2).
4. Select channel 2 and set up the source for the secondary configuration.
5. For a normalized measurement, calibrate the system and set the analyzer to display MEAS-MEM on channel 2.
6. Store this state in analyzer register 2.
7. Select channel 1 and set up the source for the primary configuration.
8. For a normalized measurement, calibrate the system and set the analyzer to display MEAS-MEM.
9. Store this state in analyzer register 1.
10. Activate the alternate sweep function on the source and enter register 2 as the alternating register.

The source alternates between the sweep conditions stored in registers 1 and 2, and the analyzer displays the measurement results for both conditions. For more information on the alternate sweep function, refer to the HP 8757 User's Guide.

Number of Trace Points and Trace Memory

The number of trace points selected defines the number of channels that the analyzer can display on the CRT. If you select 101, 201, or 401 points, the analyzer can display all four channels. Selecting 801 trace points limits the available channels to 1 and 2, and with 1601 trace points, the analyzer can display only channel 1.

Choosing 801 or 1601 points destroys the channel trace memory for the channels which were turned off.

Autozero of DC Detectors

In DC detection mode, the analyzer periodically zeros its AC/DC detectors to maintain accurate low-level measurements. When using a source connected to the 8757 system interface, you can engage the autozero function and let the analyzer control the source power off/on sequence. To preserve the source front panel settings, the analyzer must use save/recall register 9 on both the source and the analyzer. Because the analyzer accesses register 9 (and writes over existing information) each time it performs an autozero (whether forced by the operator or the autozero repeat function), do not use register 9 to store information.

Save/Recall Registers

The save/recall registers store the following information (most of the front panel settings; some system menu functions are not stored because they apply to every instrument state, rather than to a specific channel):

- The channel status (the active channel, and turned-on channels).
- Detection mode (AC or DC).
- Number of trace points.
- Internal modulation on/off status.
- Cursor on/off status.
- Cursor position.
- Cursor delta on/off status.
- Cursor delta position.
- Cursor search value.
- Adaptive normalization on/off status.1
- Non-standard sweep on/off status.
- Limit line on/off status (channels 1 and 2).
- For all channels:
 - Measurement selected (A, A/R, etc.).
 - Display mode (MEAS, MEM, etc.).
 - Averaging on/off status.
 - Averaging factor.
 - Reference level.
 - Reference position.
 - Scale per division.
 - Smoothing on/off status.
 - Smoothing factor.

Registers 1 through 4 also save the following:

- Trace memory at 401 points for channels 1 and 2.
- Limit line entries for channels 1 and 2.
- Title.

The following information applies to the entire instrument rather than the individual channels, and is *not* saved:

- System Interface on/off status.
- Labels on/off status.
- Title on/off status.
- Frequency labels on/off status.
- Repeat autozero on/off status.
- Color selection.
- CRT intensity.
- HP-IB addresses.
- Disk unit number.
- Disk volume number.

System Interface On/Off

The analyzer uses the 8757 system interface bus to control the other instruments connected to the system interface. Turn the 8757 system interface on in most applications (the CRT status line displays `SYSINTF OFF` when the system interface is off). When the system interface is off, the analyzer has no control or knowledge of any HP-IB instrument connected to this interface. To turn the system interface on, press `(SYSTEM)` and select `MORE SWEEP MODE` `SYSINTF ON`.

Remember



No two instruments connected to the system interface may have the same HP-IB address, or the analyzer may freeze operation until you correct the situation (see "Installation" for information on verifying or changing HP-IB addresses).

Turning the system interface off makes the following analyzer system functions impossible:

- Autozero of DC detectors.
- Alternate sweep.
- Start/stop/cursor frequency annotation.
- System save/recall and preset.
- System CW and manual sweep modes.
- Adaptive normalization.
- Hard copy plot and print.
- Disk access.

If you try to plot or print with the system interface turned off, the analyzer performs an instrument preset after a few seconds.

Measurement—Memory →Memory

You can use this function only with ratio measurements.

Cursor Search

Search functions differ from normal cursor operation. The cursor updates with every sweep to reflect the present amplitude response at the cursor frequency. In search left, search right, and bandwidth modes, the trace is held after the first search, and the trace freezes on the CRT so you can inspect the trace without it changing.

You can exit search mode and return to the normal cursor mode in two ways:

1. Select **PRIOR MENU** **CURSOR OFF**.
2. Press **CURSOR**.

ON-SITE SERVICE - REPAIRS

On-site analyzer repair includes assembly level troubleshooting, replacement of the defective assembly, and possible re-calibration. The equipment required to re-calibrate varies with the failure. The service manual gives complete troubleshooting instructions. This guide will quickly resolve 90% of the failures where error messages are displayed and other obvious failures (such as a dead A, B, C or R input). The motherboard must be functional, with no opens or shorts. Because of the extra equipment required to perform service and repairs, on-site service for the option 002 A5 CAL/MOD board assembly is not available. This guide is organized by error code or error message. Error code interpretation is described in "Error Codes."

Notes on Equipment Required:

Where the HP 11613A/B Calibrator is listed as required equipment, a computer with disk drive is also required. Only an HP 9000 series 200/300 Computer with a compatible disk drive can be used. The software provided with the HP 11613 includes both 3.5 inch and 5.25 inch formats. Follow the instructions provided with the calibrator.

Where a DVM is listed, use a digital voltmeter with at least 4.5 digits of resolution, except during adjustment of the A4 board, where 5.5 digits are required.

Notes on Re-calibration:

If the A1, A2, A5 (non option 002), A6, A11, A13, A14, or A16 assemblies are replaced, perform no adjustments.

The option 002 A5 board *does* require generation of cal constants on the A3 board.

If the A3, A4, A7, A8, A9, or A10 assemblies are replaced, regenerate the cal constants with the HP 11613A/B.

If the A3 assembly is replaced on an option 002 instrument, more extensive calibration equipment will be required in addition to the 11613A/B. Refer to sections 4 and 5 of the service manual for more information. If no test equipment is available and the A3 assembly must be replaced, proper calibrator operation can be restored by removing the EEPROMS (U4 and U26) from the failed A3 board and installing them onto the replacement A3 board.

If the A12 power supply is replaced, adjust all supply voltages. Adjust all power supplies within 0.05 volts of their nominal voltages. Adjust the 5 volt supplies to 5.1 volts.

Replacing the A15 display requires no adjustments although the intensity levels may vary slightly from the previous display.

If the A4 ADC board is replaced, check the DAC gain adjustment with a DVM. Use this following procedure after the analyzer has warmed up:

1. Connect DVM LO to A4TP4 (AGND) and DVM HI to A4TP2 (DAC). Both test points and A4R6 are accessible without removing the A4 assembly cover.
2. Preset the analyzer.
3. Note the maximum SWEEP DAC VOLTAGE (approximately 0.0 V) indicated on the DVM by pressing [SYSTEM] [MORE] [SERVICE] [A4 ADC] [MORE] [CHANNEL VOLTS] [CHANV OTHER] [SWP DAC MAX].
4. Note the minimum SWEEP DAC VOLTAGE on the DVM by pressing [SWP DAC MIN]. The difference between this value and the value noted in step 3 should be -10.2375 ± 0.0005 VDC. If not, adjust A4R6 (DAC ADJ) to bring the difference within specification.
5. Repeat steps 3 and 4 until this difference is attained.

MAIN ERROR CODES

■ Error Codes 15 through 13:

Failure:

All of these codes are associated with the A3 CPU board. Replacement of the A3 board will restore operation.

Equipment Required: HP 11613A/B.

■ Error Code 12:

Failure:

One or more of the power supplies have failed. First check all fuses. Remove boards one at a time (except the A3 CPU board), and cycle the power each time to check for board shorts. If none of these solve the problem, replace the A12 power supply board.

Equipment required: DVM (if the A12 is replaced.)

■ **Error Code 11:**

Failure:

The A3 CPU cannot communicate with the A6 board via the instrument bus. Either the A3, the A6, or the motherboard could be bad. Since the bus also goes to other boards, remove the A2, A4, and A14 boards to eliminate the possibility of shorts on these boards. Verify that the same failure occurs. If it does, replace all the boards that were removed, remove the A6 board, and close switch A3S1-D. This will bypass all self tests. If the instrument then seems to perform normally (locally), the problem is with the A6 board; if it does not perform normally, the problem is with the A3 board.

Equipment required: HP 11613A/B (if the A3 is replaced.)

■ **Error Code 10:**

Failure:

The A3 CPU cannot communicate with the A14 display interface board. Either board could be bad, or the ribbon cable, W8, could be bad. Since the A3 has been well tested already, there is a 90% chance that the A14 board caused the failure. No test equipment or re-calibration is required.

■ **Error Codes 9 through 3:**

Failure:

All these error codes relate to the A14 display interface board. Replacement of this board should cure the problem. No test equipment or re-calibration is required.

■ **Error Code 2:**

Failure:

The A3 CPU has encountered an interrupt it was not expecting, or did not receive one it did expect. Interrupts come from the A2, A3, A4, A6, or A14 boards. The problem could also be on the motherboard. Extensive troubleshooting is required to isolate this problem. Either substitute known working boards for those listed, or refer to the service manual for further information.

■ **Error code 1:**

Failure: A failure has occurred with either the instrument verify routine or with the other tests listed.

Equipment required: Varies with the failure.

INSTRUMENT VERIFY

- RAM: Replace the A3 CPU board.
- Instrument Bus: See error code 11.
- Display Bus: See error code 10.

- Timer: Replace the A3 CPU board.
- ADC Measurement: Check the $\pm 15V$ power supplies for accuracy. If OK, replace the A4 board.
- ADC Bit Check: Same as ADC Measurement.
- DAC Bit Check: Same as ADC Measurement.
- Sweep Compare: Same as ADC Measurement.
- Detector Control: Same as ADC Measurement.

OTHER TESTS

EEROM Write Enabled: Close switch A3S1-E. This is a warning; not a failure.

Battery Failure: Replace the battery on the A3 board, then cycle the power twice. The error message should disappear; if not, replace the A3 CPU board.

Note: The battery life should be about 10 years.

Unexpected Key Press: Either a front panel key is stuck (as indicated on the display) or the A2 board is defective. Check the indicated key or replace the A1 or the A2 board.

Configuration Error: This generally does not indicate a failure. Contact your local HP sales or service office for more information.

■ Other Problems

Default calibration table used on A, B, C, or R: This indicates a need to recalibrate using the HP 11613A/B. If the problem persists, it indicates a problem with the A3 CPU board.

If one input always seems bad and there is no detector offset active for that input, suspect the logger board for that input (A7, A8, A9, A10 for inputs A, B, C, R, respectively). Verify this by interchanging the logger board to see if the problem follows the board. Be sure to replace the boards in their original position. If the problem does not follow the board, it indicates a problem with the A4 ADC board.

Failure to sweep properly or "Sweep Sync Errors" indicate a problem on the A4 ADC board (assuming the source used is functioning properly).

Lack of any signal displayed when using the modulator drive output from the analyzer could indicate a failed A5 modulator drive board. Measure the open circuit output voltage at the MODULATOR DRIVE BNC on the rear panel. When the modulator drive is turned off, the output should be about +6.4 volts DC. When the modulator drive is on, the output voltage should be about 6 volts AC. Failure to turn on is probably caused by the A5 board, but could also be caused by the A3 CPU board.

Any of the following error messages indicate either a problem on the A3 CPU board or a problem in the firmware. If the problem occurs continuously, suspect the A3 board. If the problem only occurs during a specific keystroke sequence, it may be caused by a problem in the firmware. These messages may be accompanied with a numeric error code and flashing LEDs on the front panel and on the A3DS2 LEDs. Please note these messages and error codes when returning the instrument or board assembly to HP.

The messages are:

BUS ERROR
Adr Error
Code Err
Zero Div
Chk Instr
Trap Instr
Priv violation
Trace
-1010 emulator
-1111 emulator
Processing Error

Power Calibration Error Messages

The HP 8757D Option 002 power calibration process senses when improper connections are made. The following error messages describe the type of connection error detected. These are *not* tested during self test but rather at the beginning of or during the power cal routine.

CHECK CONNECTIONS CALIBRATION ERROR #1 The HP 8757D has detected power applied to the detector from a source other than the calibrator.

CHECK CONNECTIONS CALIBRATION ERROR #2 The HP 8757D has not measured power at the detector when the calibrator is programmed to generate power. apparently, the detector is not connected to the calibrator output, or the incorrect input was selected by the operator for calibration.

CHECK CONNECTIONS CALIBRATION ERROR #3 The HP 8757D has found that the detector was disconnected from the calibrator output before the calibration process was complete.

CALIBRATOR ERROR #1 The HP 8757D firmware has detected a problem with the calibration data stored in the instrument's CPU

EEPROM. Refer to the *Service* manual.

CALIBRATOR ERROR #2 (or greater) The HP 8757D firmware has detected a problem with the calibrator hardware. Refer to the *Service* manual.

**Detector Error
Messages (HP 85037A/B
only)**

All HP 85037A/B detectors contain cal constants within their own internal EEPROMs. Any corruption of data or digital hardware failure in the detector will generate an error message as soon as the detector is plugged in. This message is: EEPROM read failed -- A (or B, C, R)

If this message appears, the detector must be repaired or replaced.

**On-Site Service -
Calibration**

Calibration can be quickly and easily performed with the HP 11613A or 11613B calibrator. An HP 9000 series 200 or 300 computer with a compatible disk drive is also required. The software provided with the HP 11613 includes both 3.5 inch and 5.25 inch formats. Follow instructions provided with the HP 11613. Only software revision 3.0 or above should be used with the HP 8757D. The entire process (except for the analyzer warm-up) takes less than 15 minutes. No other calibration is required with the exception of the option 002. The option 002 calibration requires the use of more test equipment than is generally available for on-site service.

NOTE

Before You Start:

Proper connector care and connection techniques are critical for accurate, repeatable measurements.

Refer to the calibration kit documentation for connector care information. Prior to making connections to the network analyzer, carefully review the information about inspecting, cleaning, and gaging connectors.

Having good connector care and connection techniques extends the life of these devices. In addition, you obtain the most accurate measurements.

This type of information is typically located in Chapter 3 of the calibration kit manuals.

For additional connector care instruction, contact your local Hewlett-Packard Sales and Service Office about course numbers HP 85050A+24A and HP 85050A+24D.

See the reverse side of this notice for quick reference tips about connector care.

Principles of Microwave Connector Care-- Quick Reference Card

Handling and Storage

Do

- Keep connectors clean
- Extend sleeve or connector nut
- Use plastic end caps during storage

Do Not

- Touch mating-plane surfaces
- Set connectors contact-end down

Visual Inspection

Do

- Inspect all connectors carefully before every connection
- Look for metal particles, scratches, and dents

Do Not

- Use a damaged connector--ever

Connector Cleaning

Do

- Try compressed air first
- Use isopropyl alcohol
- Clean connector threads

Do Not

- Use any abrasives
- Get liquid into plastic support beads

Gaging Connectors

Do

- Clean and zero the gage before use
- Use the correct gage type
- Use correct end of calibration block
- Gage all connectors before first use

Do Not

- Use an out-of-spec connector

Making Connections

Do

- Align connectors carefully
- Make preliminary connection lightly
- Turn only the connector nut
- Use a torque wrench for final connect

Do Not

- Apply bending force to connection
- Overighten preliminary connection
- Twist or screw any connection
- Tighten past torque wrench "break" point

Connector Care

For

RF & Microwave Coaxial Connectors



**HEWLETT
PACKARD**

HP Part No. 08510-90064

Printed in USA 1991

Edition 2

©Copyright Hewlett-Packard Company 1991, 1400 Fountaingrove Parkway, Santa Rosa, CA
95403-1799 U.S.A.

Contents

1. Introduction	
Connectors	1-1
Precision 7 mm Connectors	1-2
Type-N Connectors	1-2
Standard Type-N	1-2
PSC-N	1-2
75 Ω Type-N	1-2
3.5 mm Connectors	1-3
SMA	1-3
Precision 3.5 mm	1-3
PSC-3.5 mm	1-3
NMD-3.5 mm	1-3
2.4 mm Connectors	1-4
The Three Grades	1-4
Production Grade	1-4
Instrument Grade	1-4
Metrology Grade	1-4
Precision 2.4 mm	1-4
PSC-2.4 mm	1-4
NMD-2.4 mm	1-4
Electrostatic Discharge	1-5
Static-Safe Work Station	1-5
Static-Safe Practices	1-5
Handling	1-6
Storing	1-6
2. Visually Inspecting & Cleaning Connectors	
Visual Inspection Procedure	2-2
1. Check for Obvious Defects	2-2
2. Check for Particles, Scratches, and Dents	2-2
Scratches	2-3
Light Burnishing	2-3
Deep Scratches	2-3
Concentric Scratches	2-3
Scratches Across the Mating Plane	2-3
Dents	2-4
Particles	2-4
Metal and Metal By-product Particles	2-4
Other Types of Particles	2-4
Cleaning Connectors	2-5
Periodically Check for Alcohol Contamination	2-5
General Cleaning Procedure	2-6

1. Use Compressed Air or Nitrogen	2-6
2. Clean the Connector Threads	2-6
3. Clean the Mating Plane Surfaces	2-6
4. Clean the Interior Surfaces	2-6
5. Dry the Connector	2-7
6. Reinspect	2-7
Precision 7 mm	2-8
Center Collet in Place	2-8
Fixed Connectors	2-8
Center Collet Removed	2-8
SMA, Precision 3.5 mm, & Precision 2.4 mm	2-9

3. Mechanically Inspecting & Connecting Connectors

When to Gage Coaxial Connectors	3-1
Connector Gages	3-2
Types	3-2
Accuracy	3-2
Using a Centering Bead	3-3
General Gaging Procedure	3-4
Precision 7 mm	3-8
Specifications	3-8
Type-N	3-10
Specifications	3-10
Electrical Effects of Contact Separation	3-13
Gaging Techniques	3-14
Male Type-N	3-14
Female Type-N	3-16
SMA	3-18
Specifications	3-18
Dielectric Protrusion	3-18
Out-of-Specification Male Pins	3-18
Gaging Techniques	3-20
Male SMA (Push-on Type Gage)	3-20
Male SMA (Screw-on Type Gage)	3-22
Female SMA (Push-on Type Gage)	3-23
Female SMA (Screw-on Type Gage)	3-24
Precision 3.5 mm	3-25
Specifications	3-25
Gaging Techniques	3-26
Male 3.5 mm (Push-on Type Gage)	3-26
Male 3.5 mm (Screw-on Type Gage)	3-28
Female 3.5 mm (Push-on Type Gage)	3-29
Female 3.5 mm (Screw-on Type Gage)	3-30
2.4 mm	3-31
Specifications	3-31
Gaging Techniques	3-32
Male 2.4 mm Connectors	3-32
Female 2.4 mm Connectors	3-33
Making Connections	3-34
General Connecting Procedure	3-34
Connecting	3-34

Disconnecting	3-39
Precision 7 mm	3-40
Seating	3-40
Type-N	3-41
3.5 mm	3-42
Mating a Precision 3.5 mm Connector to an SMA Connector	3-42
Electrical Performance	3-42
2.4 mm	3-44

A. Removing, Inspecting, & Replacing Center Conductor Collets

Collet Types	A-1
Slotted (page A-2)	A-1
Slotless (page A-4)	A-1
Slotted Collets	A-2
Removing a Center Slotted Collet	A-2
Inspecting a Slotted Collet	A-2
Replacing a Slotted Collet	A-3
Slotless Collets	A-4
HP 85052B Option K11	A-4
HP 85054B Option K11	A-4
Repairing A Slotless Contact	A-5
Inspecting A Damaged Slotless Contact	A-6
Removing A Slotless Contact	A-8
Step 1	A-8
Step 2	A-10
Step 3	A-12
Inspecting & Cleaning A Center Conductor	A-15
Inspecting	A-15
Cleaning	A-15
Inserting an Inner Contact	A-16
Testing a Slotless Contact	A-18

B. Accessories & Cleaning Supplies

Adapters	B-1
Precision 7 mm	B-2
The HP 85130B Adapter Kit	B-2
Directional Bridges	B-2
Precision 3.5 mm	B-2
Directional Bridges	B-2
Precision 2.4 mm	B-3
PSC 2.4 mm	B-3
2.4 mm-to-2.4 mm Adapters	B-3
3.5 mm-to-2.4 mm Adapters	B-3

Index

Figures

1-1. Example of a Static-Safe Work Station	1-5
2-1. Trimmed Toothpick Wrapped in a Single Layer of Lint-Free Cleaning Cloth	2-7
2-2. Cleaning a 7 mm Connector with the Connector Collet in Place	2-8
3-1. Typical Connector Gage	3-3
3-2. Zeroing a Push-on Connector Gage	3-5
3-3. Zeroing a Screw-on Connector Gage	3-7
3-4. Precision 7 mm Connector Mechanical Specifications	3-9
3-5. Type-N Connector Mechanical Specifications . . .	3-11
3-6. The Approximate Effects of Contact Separation on the Reflection Coefficient of Type-N Connectors	3-13
3-7. Gaging a Type-N Male Connector	3-15
3-8. Gaging a Type-N Female Connector Using a Push-on Type Gage	3-17
3-9. SMA Connector Mechanical Specifications	3-19
3-10. Gaging an SMA Male Connector Using a Push-on Type Gage	3-21
3-11. Gaging an SMA Male Connector Using a Screw-on Type Gage	3-22
3-12. Gaging an SMA Female Connector Using a Push-on Type Gage	3-23
3-13. Gaging an SMA Female Connector Using a Screw-on Type Gage	3-24
3-14. 3.5 mm Connector Mechanical Specifications . . .	3-25
3-15. Gaging a 3.5 mm Male Connector Using a Push-on Type Gage	3-27
3-16. Gaging a 3.5 mm Male Connector Using a Screw-on Type Gage	3-28
3-17. Gaging a 3.5 mm Female Connector Using a Push-on Type Gage	3-29
3-18. Gaging a 3.5 mm Female Connector Using a Screw-on Type Gage	3-30
3-19. 2.4 mm Connector Mechanical Specifications . . .	3-31
3-20. Gaging a 2.4 mm Male Connector	3-32
3-21. Gaging a 2.4 mm Female Connector	3-33
3-22. Align the Connectors	3-35
3-23. Make the Preliminary Connection Gently	3-35
3-24. Make the Final Connection With a Torque Wrench	3-37
3-25. Proper Torque Wrench Orientation	3-37
3-26. Do not Push the Torque Wrench Straight Down .	3-37
3-27. Tighten Only to the Torque Wrench Break Point .	3-38

3-28. Do Not Pivot the Torque Wrench on Your Thumb	3-38
3-29. Seating a Precision 7 mm Connector	3-40
3-30. A Precision 3.5 mm Connector Interface Compared to A Precision 3.5 mm-to-SMA Connector Interface	3-43
3-31. Typical SWR of SMA and Precision 3.5 mm Coupled Junctions	3-43
A-1. Using the Collet Removal Tool	A-2
A-2. Inserting a Collet	A-3
A-3. Gently Press the Collet into Place	A-3
A-4. Finger Bent In or Crushed	A-6
A-5. Broken Inner Contact	A-7
A-6. Inner Contact Pushed Inside	A-7
A-7. Damaged Center Conductor	A-7
A-8. The Inner Contact and Center Conductor	A-8
A-9. Inserting the Removal Tool	A-9
A-10. Moving a Damaged Finger	A-9
A-11. Freeing a Broken Contact Finger	A-11
A-12. Removing a Broken Contact Finger	A-11
A-13. Threading the Removal Tool into the Inner Contact	A-13
A-14. Removing the Inner Contact	A-13
A-15. Damaged Center Conductor	A-15
A-16. Holding the Inner Contact Properly	A-16
A-17. Installing a New Inner Contact	A-17
A-18. Inspecting the Installation	A-17
A-19. Inserting the Testing Tool	A-19
A-20. Testing the Retention Force of the Contact	A-19
B-1. Typical Directivity Using Connector-Saver Adapters	B-2

Tables

1-1. Connectors	1-1
B-1. Cleaning Supplies and Accessories	B-4

Introduction

Note

For a summary of general recommendations for coaxial connectors, see the Hewlett-Packard application note number 326, *Principles of Microwave Connector Care*, available from your local Hewlett-Packard representative.

Connectors**Table 1-1. Connectors**

Connector	Usable Frequency Range (GHz)
Precision 7 mm	DC to 20
Type-N	DC to 18
PSC-N	DC to 18
SMA	DC to 23
Precision 3.5 mm	DC to 34
PSC-3.5 mm	DC to 34
Precision 2.4 mm	DC to 50
PSC-2.4 mm	DC to 50

Precision 7 mm Connectors

Precision 7 mm connectors are air dielectric devices. A plastic bead inside the connector body supports the center conductor. These connectors provide the lowest SWR and the most repeatable connections of any 7 mm connector type. Durable, they are used in test and measurement applications that require a high degree of accuracy and repeatability.

Generally made of beryllium copper alloy plated with gold, these sexless connectors have replaceable inserts (collets). The collets provide contact between the center conductors, making spring-loaded butt contact when you tighten the connection.

Occasionally small mechanical differences that exist between precision 7 mm connectors made by different manufacturers can cause connection problems. Always mechanically inspect connectors to ensure they meet specifications.

Type-N Connectors

Relatively inexpensive, general-purpose, sexed connectors, these rugged 7 mm connectors perform well in severe operating environments and in applications that require repeated connections.

Standard Type-N

These connectors, made of brass, have slotted female connectors.

PSC-N

As with other precision slotless female connectors, a PSC-N connector has no slots. This stainless steel connector provides better electrical performance, repeatability of connection, and durability than a standard type-N connector.

75 Ω Type-N

A 75 Ω type-N connector has a smaller center conductor, male contact pin, and female contact hole than a 50 Ω connector. Because of this, if you mate a male 50 Ω connector with a female 75 Ω connector you either break the female contact fingers apart or permanently spread them.

3.5 mm Connectors

SMA Sexed connectors, SMA (subminiature, type A) connectors have a solid plastic dielectric that separates the center and outer conductors. These are non-precision, low-cost 3.5 mm connectors.

These connectors do not work well in applications that require repeated connections; they wear out quickly. They work best as one-time-only connectors, or in applications that require very few reconnections.

Precision 3.5 mm Precision 3.5 mm connectors are sexed, air-dielectric connectors; air provides the insulating dielectric between the center and outer conductors. A plastic bead inside the connector body supports the center conductor.

Precision 3.5 mm connectors will mate with SMA connectors, and (unlike SMA connectors) are durable enough for repeated connections.

PSC-3.5 mm

As with other precision slotless female connectors, a PSC-3.5 mm connector has no slots. This connector provides better electrical performance, repeatability of connection, and durability than a standard precision 3.5 mm connector.

NMD-3.5 mm

Hewlett-Packard uses these rugged 3.5 mm connectors on cables, test port connectors, and on special adapters. These connectors have larger-than-standard coupling threads, providing an exceptionally strong coupling mechanism for measurement applications.

Female NMD connectors (used on the test set end of adapters and cables) *cannot* be connected to standard male 3.5 mm connectors.

Male NMD connectors (used on test sets (as test ports), and on the DUT end of adapters and cables) have *both* larger threads (to connect to female NMD connectors) *and* standard threads (to directly couple to a device under test).

2.4 mm Connectors

The Three Grades

Production Grade

Also defined as “economy,” this grade applies to connectors used in components, cabling and microstrip applications. This grade, usually used internal to instruments, has a slotted female center conductor.

Instrument Grade

These connectors, principally intended for use in precision test and measurement equipment, maintain high performance during many connect-disconnect cycles. This grade, usually used external to instruments, has a slotted female center conductor.

Metrology Grade

These connectors, used on measurement standards that require a high degree of dimensional precision, have direct traceability to national measurement standards through well-defined mechanical dimensions. This grade of connector has a slottless female center conductor.

Precision 2.4 mm

These sexed connectors have air as the dielectric; air provides the insulating dielectric between the center and outer conductors. A plastic bead inside the connector body supports the center conductor.

PSC-2.4 mm

As with other precision slotless female connectors, a PSC-2.4 mm connector has no slots. This connector provides better electrical performance, repeatability of connection, and durability than a standard precision 2.4 mm connector.

NMD-2.4 mm

Hewlett-Packard uses these rugged 2.4 mm connectors on cables, test port connectors, and on special adapters. These connectors have larger-than-standard coupling threads, providing an exceptionally strong coupling mechanism for measurement applications.

Female NMD connectors (used on the test set end of adapters and cables) *cannot* be connected to standard male 2.4 mm connectors.

Male NMD connectors (used on test sets (as test ports), and on the DUT end of adapters and cables) have *both* larger threads (to connect to female NMD connectors), *and* standard threads (to directly couple to a device under test).

Electrostatic Discharge

Protect against electrostatic discharge before cleaning or inspecting a connector attached to a static-sensitive circuit. Static electricity builds up on the body, on calibration components, and on devices under test, and can easily damage sensitive circuits when discharged by contact with a center conductor. A static discharge too small to feel can cause permanent damage.

Static-Safe Work Station

Figure 1-1 illustrates a static-safe station using two types of ESD protection that you can use either together or separately (see Appendix B for ordering information):

- A conductive table mat and wrist-strap combination.
- A conductive floor mat and heel-strap combination.

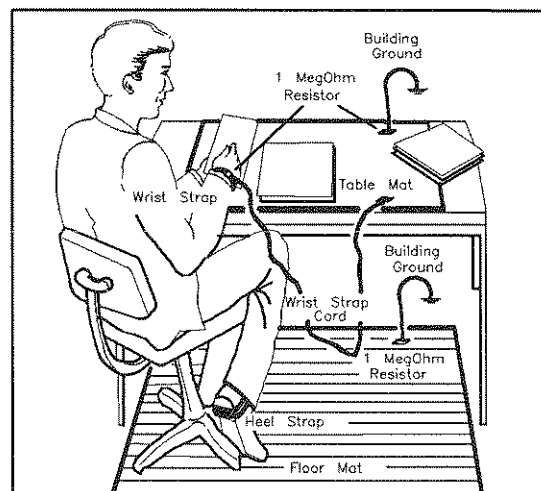

Figure 1-1. Example of a Static-Safe Work Station

Static-Safe Practices

- Before cleaning, inspecting, or making a connection to a static-sensitive device or test port, ground yourself at a grounded device as far as possible from the test port.
- Discharge static electricity from a device before connecting it:

Touch the device briefly (through a resistor of at least $2\text{ M}\Omega$) to either the outer shell of the test port, or another exposed ground. This discharges static electricity and protects test equipment circuitry.

Handling

Handle connectors carefully, and inspect them before use:

1. Keep connectors clean.
2. Do not touch mating plane surfaces. Natural skin oils and microscopic particles of dirt (easily transferred to a connector interface) are difficult to remove.
3. Do not set connectors contact-end down on a hard surface. You can damage the plating and the mating plane surfaces if the interface comes in contact with a hard surface.

Storing

When not using a device, store it in a way that gives it maximum protection:

1. Before storing a connector, extend the sleeve or connector nut. This protects the mating surfaces.
2. When you are not using a connector, use plastic end caps over the mating plane surfaces to keep them clean and protected.
3. Never store connectors loosely in a box, or drawer (the most common cause of connector damage during storage).

Store calibration devices, verification devices, and test fixtures in a foam-lined storage case.

4. Store cables in the same shape they have when you use them; do not either straighten a cable or flex it more tightly. Even flexible cables last longer if you flex them as little as possible.

Visually Inspecting & Cleaning Connectors

Because of the small size of some coaxial connectors, and because of very precise mechanical tolerances (on the order of a few hundreds of microinches in some cases), minor defects, damage, and dirt can significantly degrade repeatability and accuracy. In addition, a precision connector mating surface may have gold plating, making it susceptible to mechanical damage because of the softness of the metal. A dirty or damaged connector can destroy any connector mated to it.

Caution

Never use a damaged connector.

Note

You do not need to magnify a connector when you inspect it. In fact, inspecting a connector under magnification can mislead you. Defects and damage that you cannot see without magnification generally have no effect on the electrical or mechanical performance of a coaxial connector.

Visual Inspection Procedure

1. Check for Obvious Defects

Before each connection, visually inspect all connectors. If necessary, clean the connectors each time you make a connection.

Look for obvious defects or damage (badly worn plating, deformed threads, or bent, broken, or misaligned center conductors). Connector nuts should move smoothly and have no burrs, loose metal particles, or rough spots.

Discard or send for repair any connector with an obvious defect.

2. Check for Particles, Scratches, and Dents

Metal particles from the connectors threads can adhere to the mating plane surfaces when you disconnect a connector.

Check for:

- Flat contact between the connectors at all points on their mating plane surfaces.
- Deep scratches (see “Scratches”).
- Dents (see “Dents”).
- Dirt, or metal particles (see “Metal and Metal By-Product Particles”).
- Bent or rounded edges on the center and outer conductor mating plane surfaces.
- Any sign of damage due to excessive or uneven wear or misalignment.

If a connector shows deep scratches or dents, particles clinging to the mating plane surfaces, or uneven wear, clean it and inspect it again.

Determine the cause and extent of the damage before using a connector that has dents or scratches deep enough to displace metal on the connector mating plane surface.

Scratches

On a gold plated connector, a scratch that goes through the gold plating to the metal underneath can cause trouble. The exposed bimetal surface accelerates corrosion and needs cleaning more often than an all-gold surface. Inspect the scratch carefully under magnification to see if it left a high spot of pushed-up metal on the mating plane surface. If so, do not use the connector; it will damage any connector you mate to it.

If you remove all metal displaced by a scratch, or it wears away (so that no high spots remain), the connector may work. Full, flat circular contact between the mating plane surfaces may not happen, but the connection may prove satisfactory for most purposes.

Light Burnishing

Light burnishing (light scratches or shallow circular marks distributed uniformly over the mating plane surface) does not affect electrical or mechanical performance. Burnishing (caused by the normal, slight rotation of the mating planes against one another as you make a connection) and other small defects and cosmetic imperfections are normal.

Deep Scratches

Individual, hard particles (metal particles or burrs left from machining) cause deep scratches. These particles slide across the mating plane surface and displace metal.

Concentric Scratches

Deep scratches running concentrically (like the groove in a phonograph record) generally indicate that one or both of the connector mating plane surfaces were not perfectly clean, or that one of the connectors has a burr or high spot on its surface.

Long scratches running concentrically generally indicate too much rotation on a connector, or a connector nut that seizes during connection.

Scratches Across the Mating Plane

Most often, deep scratches that run across the mating plane surface result from rough handling during connection, disconnection, or storage.

Dents

You usually find dents on the outside edge of a mating plane surface. Under magnification a dent looks like a small crater or valley, with metal pushed outward and upward from the point of impact.

Careless handling or assembly of a connector during manufacture can cause dents, but more often a dent results from dirt or metallic particles pressing into the mating plane surface. This can happen during connection or during storage. Even a work surface that looks clean can have particles on it large enough and hard enough to, with pressure, dent or scratch a connector. Sudden, sharp, metal-to-metal impact, (such as when a connector drops or has another metal part bumped against it) can also cause dents.

A connectors that has a dent anywhere on the mating plane surfaces will not make perfect contact, and the raised edges will dent any connector mated to it. Except for very slight damage, replace a dented connector.

Particles

Metal and Metal By-product Particles

Metal and metal by-product particles on connector mating plane surfaces often come from the connector nut threads. These very hard particles can scratch or dent a connector's gold plating. If you find these particles, completely clean the connector (see "Cleaning Connectors") then reinspect it.

Other Types of Particles

You can also contaminate a connector with particle by setting the connector contact-end down on a work surface (even though the surface looks clean) or by touching the mating plane surfaces. You can usually remove particles left behind after cleaning by blowing the connector dry with clean, compressed air.

Cleaning Connectors

For a long, reliable connector life, carefully clean all connectors. Appendix B lists part numbers for recommended cleaning supplies.

Periodically Check for Alcohol Contamination

1. Let a few drops of alcohol evaporate on a clean glass plate or microscope slide.
2. Examine the glass in reflected light. It should be perfectly clean and free of residue. If not, do not use the alcohol from that container.

To keep your main supply of alcohol free from contamination, pour a small amount into a clean container and use that as your cleaning supply. Safely discard any remaining alcohol in the small container and clean the container.

Cautions



If you must use a solvent, use *only* isopropyl alcohol.

Use the least amount of alcohol possible, and avoid wetting any plastic parts in the connectors.

On 3.5 mm (and smaller) connectors, openings are very small, interior surfaces difficult to reach, and generally a plastic dielectric bead supports the center conductor only at the inner end. You can easily bend or break the center conductor.

General Cleaning Procedure

Warnings



Always use protective eyewear when using compressed air or nitrogen.

This procedure assumes you have taken the necessary ESD precautions.

1. Use Compressed Air or Nitrogen

1. Use compressed air (or nitrogen) to loosen particles on the connector mating plane surfaces. Clean air cannot damage a connector, or leave particles or residues behind.

You can use any source of clean, dry, low-pressure compressed air or nitrogen that has an effective oil-vapor filter and liquid condensation trap placed just before the outlet hose. Ground the hose nozzle to prevent electrostatic discharge, and set the air pressure to a very low velocity (<60 psi). High-velocity air can cause electrostatic effects when directed into a connector.

2. Clean the Connector Threads

For dirt or stubborn contaminants on a connector that you cannot remove with compressed air or nitrogen, try a foam swab or lint-free cleaning cloth moistened with isopropyl alcohol:

- a. Apply a small amount of isopropyl alcohol to a foam swab or a lint-free cleaning cloth.
- b. Clean the connector threads.
- c. Let the alcohol evaporate, then blow the threads dry with a gentle stream of clean, low-pressure compressed air or nitrogen.

3. Clean the Mating Plane Surfaces

- a. Apply a small amount of isopropyl alcohol to a new swab and clean the mating plane surfaces.

If the connector has a center conductor, use very short horizontal or vertical strokes (across the connector), and the least pressure possible, especially when cleaning a female connector (to avoid snagging the cleaning swab on the center conductor contact fingers). An illuminated magnifying glass helps.

4. Clean the Interior Surfaces

In the following steps, use the proper size toothpick. The wooden handle of a foam swab, for example, is too large even if it fits into the connector.

- For 3.5 mm connectors, use a toothpick with a diameter no greater than 1.7 mm (0.070 in).
- For precision 2.4 mm connectors, use a toothpick with a diameter no greater than 1.2 mm (0.047 in).

Caution

Never use metal in place of a toothpick, it will scratch the plated surfaces.

- a. Cut off the sharp tip off a round, wooden toothpick.
- b. Wrap the trimmed toothpick with a single layer of lint-free cleaning cloth (see Figure 2-1).

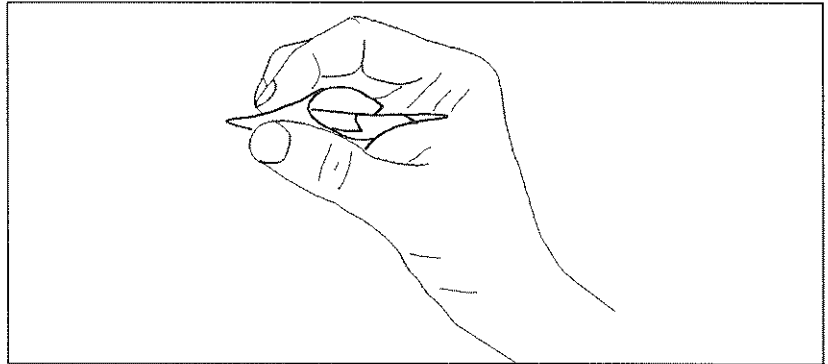

Figure 2-1.
Trimmed Toothpick Wrapped in a Single Layer of Lint-Free Cleaning Cloth

- c. Moisten the cloth with a small amount of isopropyl alcohol and carefully insert it into the connector. To clearly see the areas you wish to clean, use an illuminated magnifying glass or microscope.

5. Dry the Connector

After cleaning, blow the connector dry with a gentle stream of clean compressed air or nitrogen. Always completely dry a connector before you reassemble or use it.

6. Reinspect

Inspect the connector again under a magnifying glass to be sure that no particles or residues remain.

Precision 7 mm

Center Collet in Place

You do not have to remove the center conductor collet to clean a precision 7 mm connector. With the center collet in place:

1. Put a lint-free cleaning cloth flat on a table.
2. Put a drop or two of isopropyl alcohol in the center of the cloth.
3. Retract the connector sleeve threads to expose the connector interface.
4. Gently press the contact end of the connector into the moistened cloth and turn the connector (Figure 2-2). The cloth scrubs away dirt on the connector interface without damaging the connector.
5. Blow the connector dry with a gentle stream of compressed air or nitrogen.
6. When not in use, keep the cloth in a plastic bag or box so that it does not collect dust or dirt.

Fixed Connectors

Use the following procedure to clean a fixed connector:

1. Fold a lint-free cleaning cloth several times.
2. Moisten the cloth with isopropyl alcohol.
3. Press the moistened cloth against the connector interface and turn the cloth to clean the connector.
4. Blow the connector dry with a gentle stream of compressed air or nitrogen.

Center Collet Removed

Clean and inspect the interior surfaces any time you remove the center conductor collet. Use a wooden toothpick and lint-free cleaning cloth, as described in the general cleaning procedure.

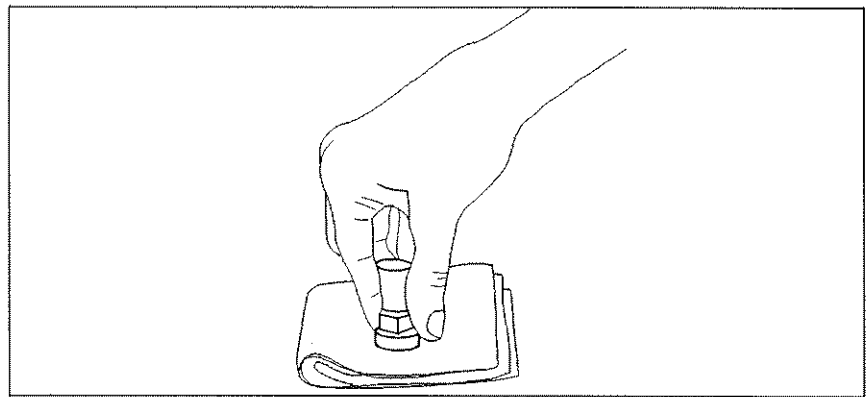

Figure 2-2.
Cleaning a 7 mm Connector with the Connector Collet in Place

**SMA,
Precision 3.5 mm, &
Precision 2.4 mm**

Because of their delicacy, small size, and intricate geometry, clean these connectors carefully. The center conductor contact pins, and especially the contact fingers on female connectors, can easily bend or break. In the precision connectors, a plastic dielectric bead supports the center conductor only at the inner end.

Use the general cleaning procedure.

1
2
3
4
5
6
7
8
9
10
11
12
13
14
15
16
17
18
19
20
21
22
23
24
25
26
27
28
29
30
31
32
33
34
35
36
37
38
39
40
41
42
43
44
45
46
47
48
49
50
51
52
53
54
55
56
57
58
59
60
61
62
63
64
65
66
67
68
69
70
71
72
73
74
75
76
77
78
79
80
81
82
83
84
85
86
87
88
89
90
91
92
93
94
95
96
97
98
99
100



Mechanically Inspecting & Connecting Connectors

Because coaxial connector mechanical tolerances can be very precise (on the order of a few hundreds of microinches), even a perfectly clean, unused connector can cause trouble if out of mechanical specification. Use a connector gage to mechanically inspect coaxial connectors.

When to Gage Coaxial Connectors

Gage a connector:

- Before you use it for the first time.
- If either visual inspection or electrical performance suggests that the connector interface may be out of specification (due to wear or damage, for example).
- If someone else uses the device.
- If you use the device on another system or piece of equipment.
- As a matter of routine: initially after every 100 connections, and after that as often as experience suggests.

Note



Gage 2.4 mm, 3.5 mm, and SMA connectors relatively more often than other connectors, because the center pins can pull out of specification during disconnection.

Connector Gages

Types

Each type of connector uses a different connector gage (Figure 3-1 shows a typical connector gage):

- There are push-on type gages and screw-on type gages.
- Sexed connectors use either two gages (one male and one female), or (in the case of type-N connectors) a single gage with male and female adapter bushings.
- Every connector gage requires a gage calibration block (to zero the gage).
- Connector gages for precision 7 mm connectors also require an aligning pin and pin wrench to measure the center conductor depth of beadless airlines with the centering pin removed.

Appendix B lists connector gage kits containing the gages recommended for coaxial connectors. Also, many calibration kits include connector gages.

Caution



Use the proper gage for your connector (see Appendix B). Some gages have a very strong gage plunger spring that, if used on the wrong connector, can push the center conductor back through the connector, damaging the device itself. Other gages, if used improperly, can compress the center conductor collet in precision 7 mm connectors during a measurement, giving an inaccurate reading when you measure the collet protrusion.

Accuracy

Because of connector gage measurement uncertainties (typically one small division on the dial) and variations in measurement technique from user to user, connector setback dimensions are difficult to measure.

For example, if you use a gage with 0.0001-inch small divisions on the dial to measure a connector that has an actual setback of 0.0005 inches, you can get a gage reading from 0.0004 to 0.0006 inches, depending on the gage (due strictly to gage measurement uncertainty). Note that other variables (such as cleaning and gage technique) can increase this range of readings. Before you decide a connector fails specification, do the following:

1. Carefully clean the connector, the connector gage, and the gage block again.
2. Zero the gage again.
3. Repeat the measurement.

Dirt and contamination can be affected measurements in which differences of 0.0001 inch are significant.

4. After you measure the connector several times yourself, have another person measure the connector several times. This helps reduce uncertainties due to differences of technique and random variations in gage accuracy.
5. Keep records of the setback measurements for each device over time. Noticeable differences from one set of measurements to the next can indicate errors in measurement technique, or that a damaged connector needs replacing.

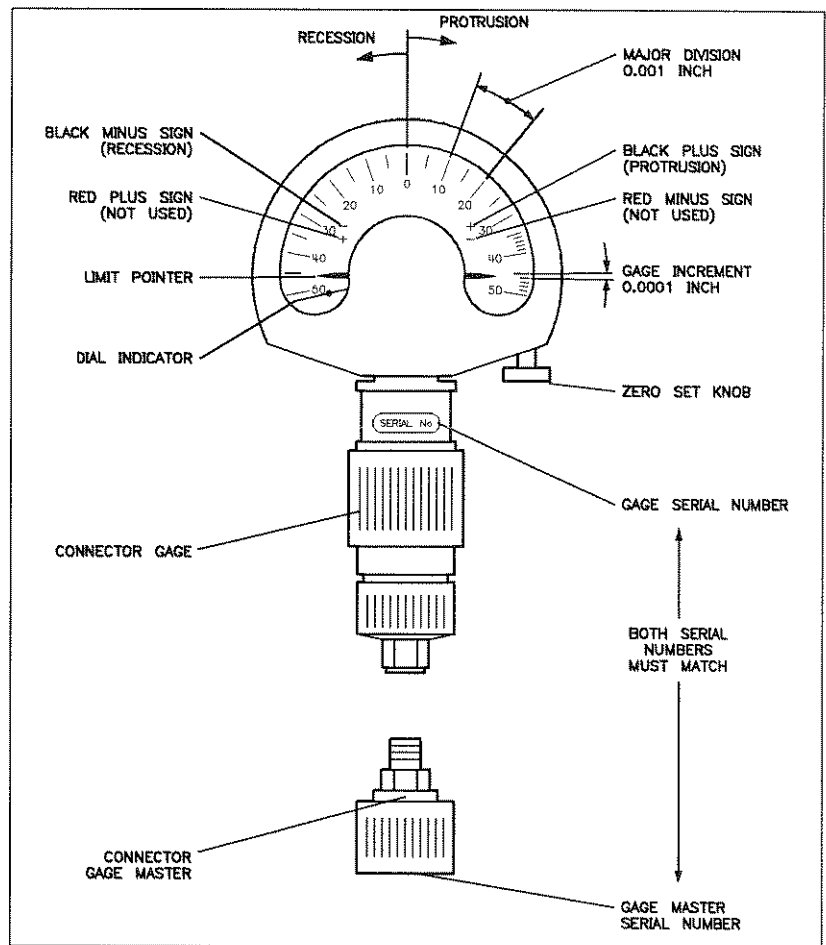

Figure 3-1. Typical Connector Gage

Using a Centering Bead

Use a centering bead to keep a sliding load or airline beadless center conductor centered as you connect it to a *gage*. Always remove the centering bead before you connect the device to anything other than a *gage*. If you leave the bead on, the device will fail its electrical specifications.

General Gaging Procedure

Caution



Before you gage a connector, consult the mechanical specifications provided with that connector or device.

Notes



Hold a connector gage by the gage barrel, below the dial indicator. This gives the best stability, and improves measurement accuracy (cradling the gage in your hand or holding it by the dial applies stresses to the gage plunger mechanism through the dial indicator housing).

When you measure a connector several times, use different orientations of the gage within the connector. Averaging several readings, each taken after a quarter-turn rotation of the gage, reduces measurement variations that result from the gage or the connector face not being exactly perpendicular to the center axis.

Because of the differences in the outer conductor of measured devices and the amount of pressure applied, screw on and press on type gages give slightly different readings.

1. Select the proper gage for your connector.
2. Inspect and clean the gage:
 - a. Inspect the connector gage and the gage calibration block carefully, exactly as you inspected the connector itself.
 - b. Clean or replace the gage and the gage calibration block if necessary.

Dirt on either the gage or the gage calibration block makes gage measurements inaccurate, and can damage a connector.
3. Zero the gage:

Push-on Type (see Figure 3-2):

 - a. Hold the gage by the plunger barrel (not the dial housing or cap). This prevents gage reading errors caused by stresses to the gage plunger mechanism through the dial indicator housing.
 - i. For male connectors, slip the protruding end of the calibration block into the circular bushing on the connector gage.
 - ii. For precision 7 mm connectors, and female precision 3.5 mm connectors, use the flat end of the gage calibration block.
 - iii. For female type-N connectors, use the recessed end of the gage calibration block.

- b. Carefully bring the gage and gage block together. Apply only enough pressure to the gage and gage block to settle the dial indicator pointer at a reading.
- c. Gently rock the two surfaces together, to make sure that they have come together flatly.

The gage pointer should line up exactly with the zero mark on the gage. If not, inspect and clean the gage and gage calibration block again and repeat this process. If the gage pointer still does not line up with the zero mark on the gage, loosen the dial lock screw and turn the graduated dial until the gage pointer exactly lines up with zero. Then re-tighten the lock screw.

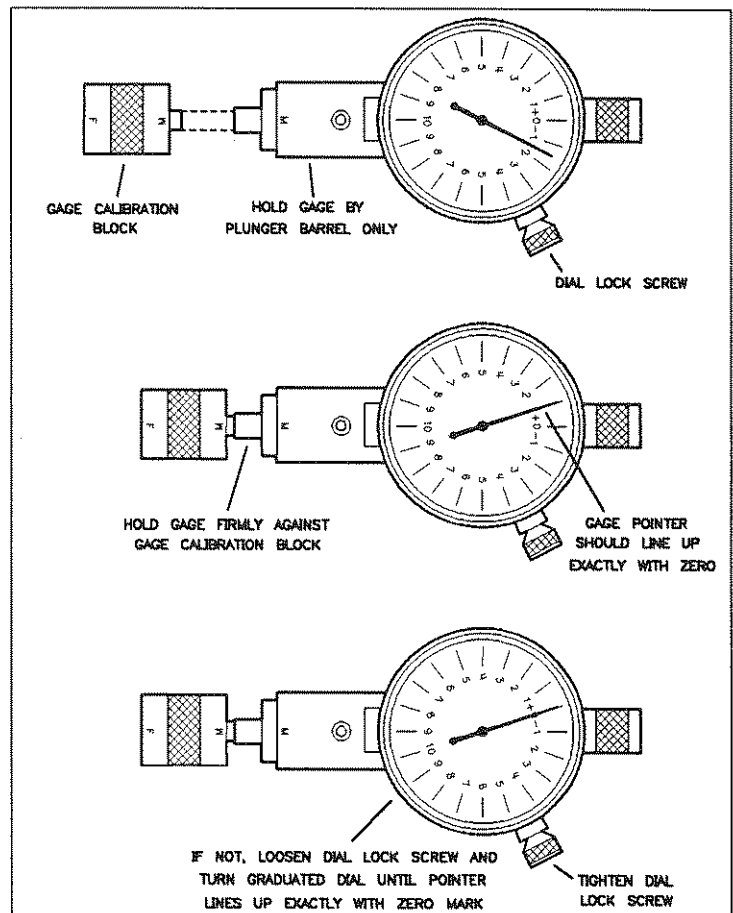

Figure 3-2. Zeroing a Push-on Connector Gage

Screw-on Type (see Figure 3-3):

- a. Holding the gage by the plunger barrel, screw on the calibration device just until you meet resistance.
- b. Use a torque wrench to tighten the connection.
- c. As you watch the gage pointer, gently tap the calibration device .

The gage pointer should line up exactly with the zero mark on the gage. If not, adjust the zero set knob until the gage pointer exactly lines up with zero.

Note



Check gages often to make sure that the zero setting has not changed. Generally, when the pointer on a recently zeroed gage does not line up exactly with the zero mark, the gage or calibration block needs cleaning. Clean both of these carefully and check the zero setting again.

4. Measure the connector.

Measure the recession of the center conductor behind the outer conductor mating plane exactly the same way you zeroed the gage, but *do not* reset the graduated dial.

5. For the best accuracy, measure the connector several times (rotating the gage relative to the connector between each measurement), and take an average of the readings.
6. To monitor connector wear, record the readings for each connector over time.

- Hand tighten the calibration block onto the gage

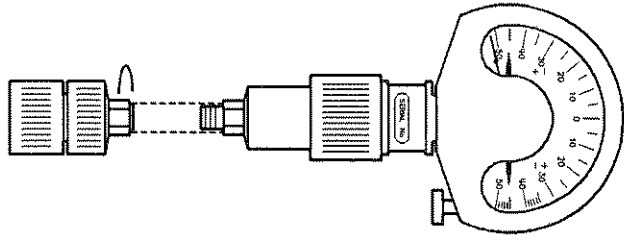

- Torque the calibration block onto the gage and tap the block to settle the gage pointer

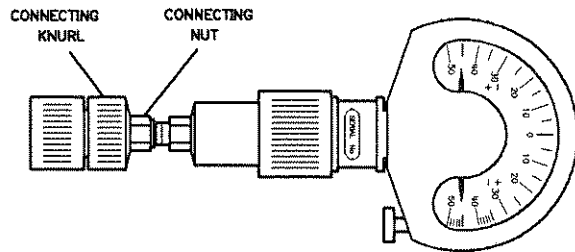

- Zero the gage

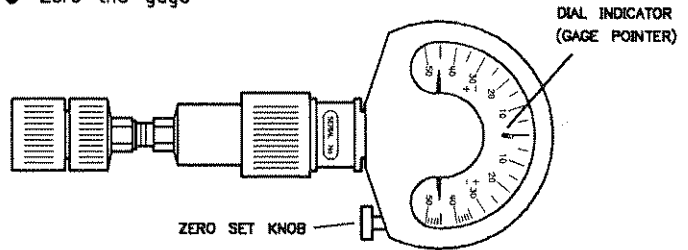

Figure 3-3. Zeroing a Screw-on Connector Gage

Precision 7 mm

In precision 7 mm connectors (Figure 3-4), replaceable inserts (collets) that make spring-loaded butt contact when you tighten the connection provide contact between the center conductors. The collets protrude slightly in front of the outer conductor mating plane when the connectors are apart. When the connection tightens, the collets compress into the same plane as the outer conductors.

Specifications

Two mechanical specifications are generally given for precision 7 mm connectors:

1. A minimum and maximum allowable protrusion of the center conductor collet in front of the outer conductor mating plane with the collet in place.
 - a. Measure the collet protrusion.
 - b. If attached, remove the aligning pin from the connector gage.
 - c. Use the flat end of the gage calibration block.
2. The maximum recession of the center conductor behind the outer conductor mating plane with the center conductor collet removed.
 - a. Measure the center conductor recession.
 - b. The center conductor must not protrude beyond the outer conductor mating plane.
 - c. For an airline, attach the aligning pin to the connector gage and use the recessed end of the gage calibration block.

Also, the center conductor collet should immediately spring back if you compress it fully with a blunt plastic rod or with the rounded plastic handle of the collet removing tool.

Caution



With the center conductor collet removed, the center conductor may not protrude in front of the outer conductor mating plane, and sometimes must recede minimally. Consult the mechanical specifications provided with your connector or device.

Note



Before you gage a precision 7 mm connector, fully extend the sleeve. This creates a cylinder into which the gage fits, minimizing the danger of the gage slipping sideways and damaging the connector.

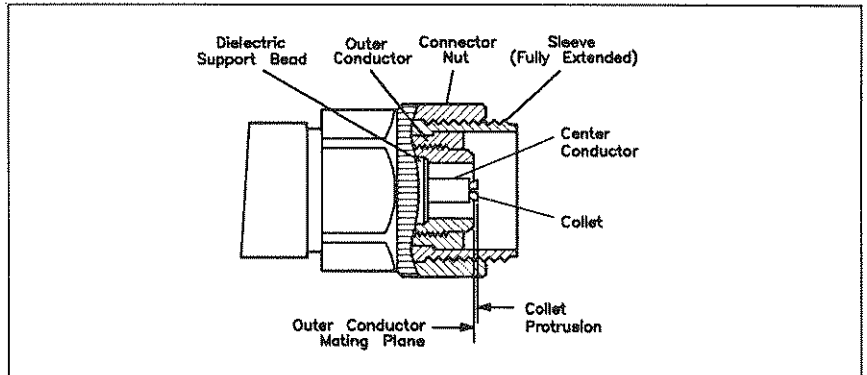

Figure 3-4. Precision 7 mm Connector Mechanical Specifications

Type-N

A type-N connector differs from other connector types in that its outer conductor mating plane is offset from the mating plane of the center conductor (Figure 3-5). The outer conductor sleeve in the male connector extends in front of the shoulder of the male contact pin. When you make a connection, this outer conductor sleeve fits into a recess in the female outer conductor behind the plane defined by the tip of the female contact fingers.

In a male type-N connector, the position of the shoulder of the male contact pin (not the position of the tip) defines the position of the center conductor. The male contact pin slides into the female contact fingers; the inside surfaces of the tip of the female contact fingers on the sides of the male contact pin provide electrical contact.

Specifications

Type-N connector critical mechanical specifications:

- A maximum protrusion of the female center conductor in front of the outer conductor mating plane.
- A minimum recession of the shoulder of the male contact pin behind the outer conductor mating plane (0.207 inches).
- A maximum recession of the shoulder of the male contact pin behind the outer conductor mating plane (0.210 inches).

In the Hewlett-Packard precision specification for type-N connectors, the male contact pin shoulder minimum allowable recession is 0.001 inches *less* than in the MIL-C-39012, Class II specification.

As type-N connectors wear, the protrusion of the female contact fingers generally increases, due to wear of the outer conductor mating plane inside the female connector. Check this periodically, because it decreases the total center conductor contact separation.

Cautions



Never use a type-N connector if the possibility of interference between the shoulder of the male contact pin and the tip of the female contact fingers exists; *do not* mate type-N connectors if, when you make the connection, the separation between the tip of the female contact fingers and the shoulder of the male contact pin could measure less than zero.

If you use both 75 and 50Ω type-N connectors, mark the 75Ω connectors so that you never accidentally mate them with 50Ω connectors. The center conductor, male contact pin, and female contact hole are smaller on 75Ω connectors.

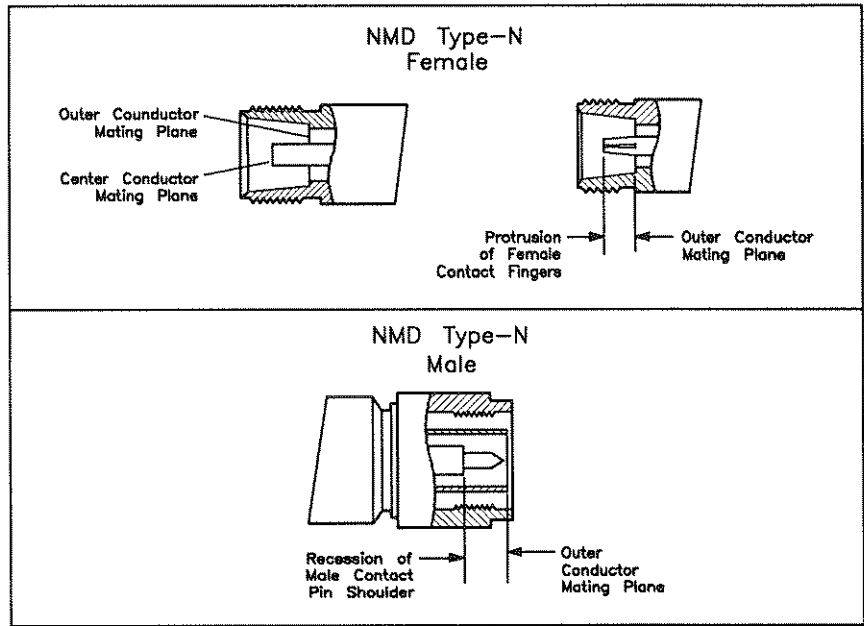

Figure 3-5. Type-N Connector Mechanical Specifications

Type-N

Electrical Effects of Contact Separation

You may be able to use a type-N connector in an application where the total separation between the shoulder of the male contact pin and the tip of the female contact fingers exceeds the maximum implied by the mechanical specifications. Figure 3-6 shows the approximate effects of total contact separation on the reflection coefficient of standard (*not* PSC) type-N connections. At lower frequencies, the effects (even of fairly wide total contact separation) are small; at higher frequencies, contact separation becomes important.

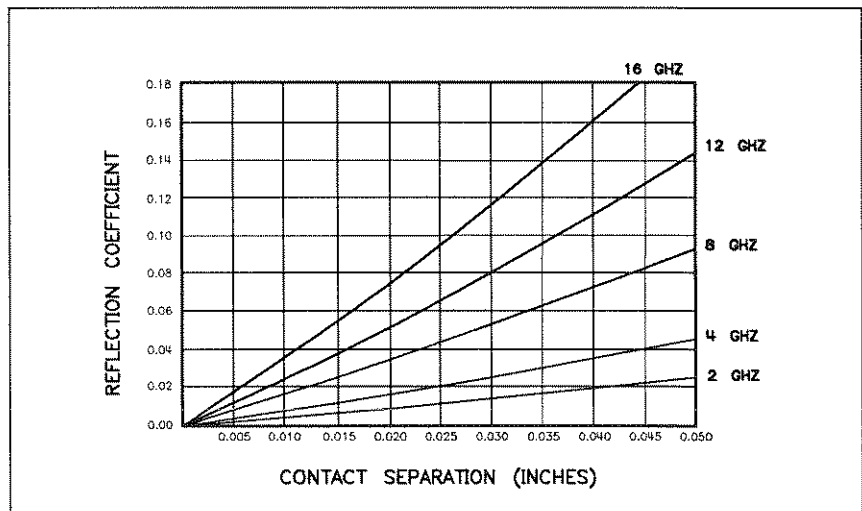

Figure 3-6.
The Approximate Effects of Contact Separation on the Reflection Coefficient of Type-N Connectors

Gaging Techniques

Male Type-N

1. Refer to Figure 3-7.
2. Attach the bushing for male connectors to the dial indicator assembly.
3. Slip the bushing over the gage plunger assembly and fasten it with the two Allen screws in the bushing.

The male bushing has a flat outer end with a hole in it. Insert the gage plunger through the bushing so that with the bushing attached, the plunger protrudes from the bushing.

4. Using the recessed end of the gage calibration block, zero the gage as described in the general procedure at the beginning of this chapter.
5. Measure the connector:
 - a. Carefully center and insert the gage into the male connector; the flat outer part of the gage bushing rests on the outer conductor (the male contact pin slips into the hole in the gage plunger for this purpose).
 - b. Gently rock the connector gage within the connector to make sure the gage and the outer conductor mate flatly.
 - c. When the gage pointer settles consistently at a reading, read the gage indicator dial.

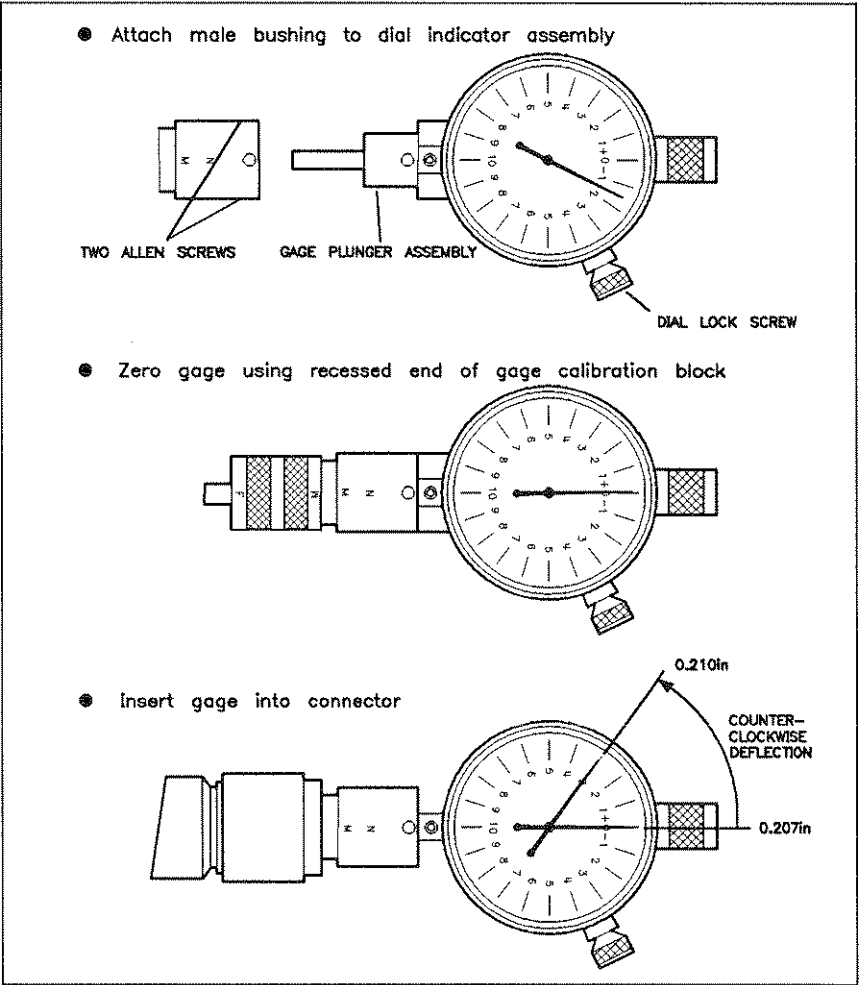

Figure 3-7. Gaging a Type-N Male Connector

Female Type-N

1. Refer to Figure 3-8.
2. Attach the bushing for female connectors to the dial indicator assembly. This bushing has a protruding circular sleeve.
3. Slip the bushing over the gage plunger assembly and fasten it with the two Allen screws in the bushing.
4. Insert the protruding end of the gage calibration block into the circular sleeve so it comes to rest on the gage plunger inside the female bushing.
5. Zero the gage as described in the general procedure at the beginning of this chapter.
6. Measure the connector:
 - a. Carefully center and insert the gage into the female connector; the female contact fingers in the connector slip inside the protruding circular sleeve on the gage.

The circular sleeve on the bushing should come to rest on the outer conductor mating plane inside the connector, behind the female contact fingers.

- b. Gently rock the connector gage within the connector to make sure the gage and the outer conductor are together flatly.
 - c. When the gage pointer settles consistently at a reading, read the gage indicator dial.

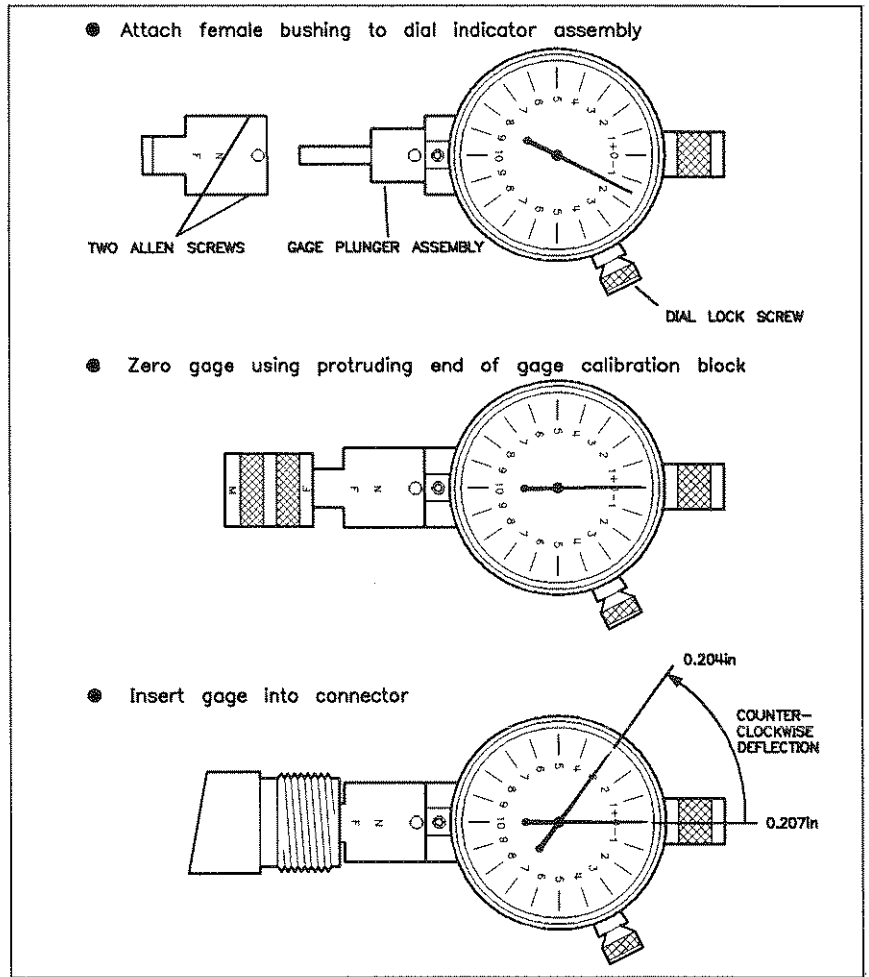

Figure 3-8.
Gaging a Type-N Female Connector Using a Push-on Type Gage

SMA

SMA connectors are sexed connectors. The male contact pin slides into the female contact fingers; the inside surfaces of the tip of the female contact fingers on the sides of the male contact pin provide electrical contact.

Specifications

- A maximum and minimum recession of the shoulder of the male contact pin.
- A maximum and minimum recession of the tip of the female center conductor behind the outer conductor mating plane.

Dielectric Protrusion

Some SMA connector specifications allow protrusion of the solid plastic dielectric in front of the outer conductor mating plane (as much as 0.003 inches). This does not harm an SMA connector mated to another SMA connector, because some compression of the dielectric can occur, but protruding dielectric can force the rigid center conductor of a precision 3.5 mm connector back through the connector itself, damaging both the connector and the device to which you attach it.

Out-of-Specification Male Pins

Some SMA connectors have insecurely held male contact pins, making them easy to pull out of specification (especially with tight female connector contact fingers). Also, some SMA male pins are not true pins, but the cut-off ends of the center conductor in semi-rigid coaxial cable. In this case, misalignment and burrs are not unusual.

Cautions

Neither the shoulder of the male contact pin nor of the tip of the female contact fingers may protrude in front of the outer conductor mating plane, and sometimes must *recede* minimally. Consult the mechanical specifications provided with your connector or device.

Never mate a precision 3.5 mm connector to an SMA connector in which the solid plastic dielectric protrudes in front of the outer conductor mating plane.

Inspect all male SMA connectors for misalignment or burrs on the male contact pin. Discard any that are damaged.

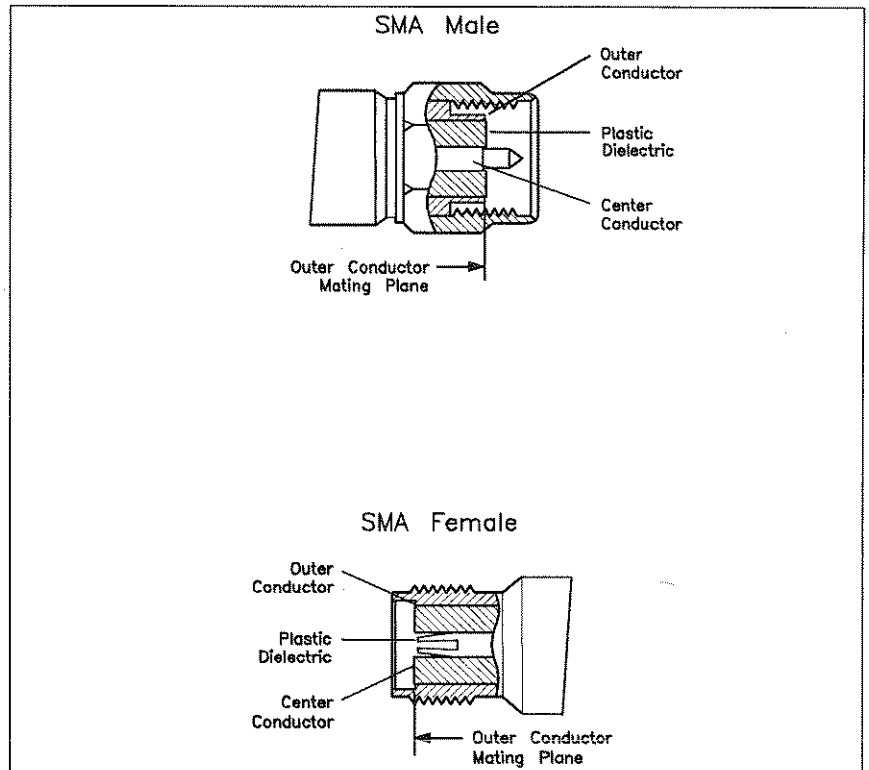

Figure 3-9. SMA Connector Mechanical Specifications

Gaging Techniques

Male SMA (Push-on Type Gage)

1. Refer to Figure 3-10. The male SMA connector gage (usually marked M) has a circular metal bushing surrounding the gage plunger.
2. Use the protruding end of the gage calibration block (also usually marked M).
3. Slip the calibration block into the outer bushing so that the bushing comes to rest on the outer, flat area of the calibration block. When you measure a connector, the gage outer bushing rests on the outer conductor mating plane inside the connector.
4. Zero the gage as described in the general procedure at the beginning of this chapter.
5. Measure the connector:
 - a. Carefully center and insert the gage into the male connector; the flat outer part of the gage bushing rests on the outer conductor (the male contact pin slips into the hole in the gage plunger for this purpose).
 - b. Gently rock the connector gage within the connector to make sure the gage and the outer conductor mate flatly.
 - c. When the gage pointer settles consistently at a reading, read the gage indicator dial.

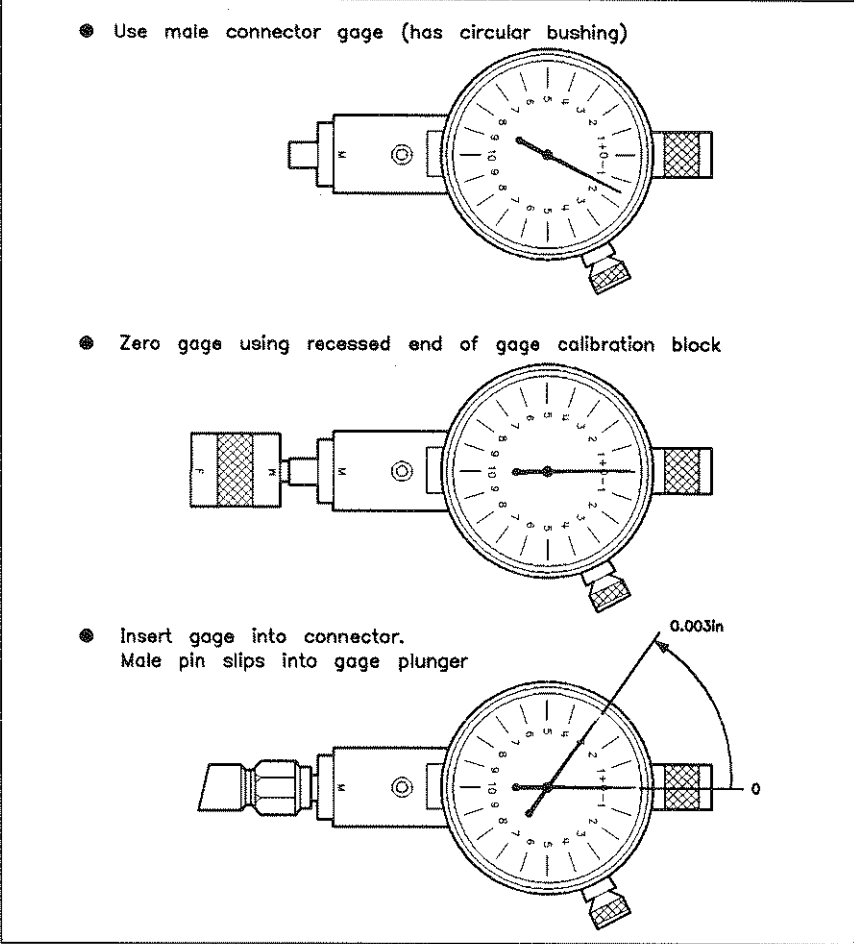

Figure 3-10.
Gaging an SMA Male Connector Using a Push-on Type Gage

Male SMA (Screw-on Type Gage)

1. Refer to Figure 3-11.
2. Use the steps in the general procedure at the beginning of this chapter to zero the gage.
3. Hold the gage by the barrel only and screw it on the connector, connecting the knurl (do not turn the gage or the device) finger-tight.
4. Torque the connector onto the gage to 56 N-cm (5 in-lb).
5. Tap the connector with your finger to settle the gage.
6. Read the gage indicator dial.
7. For maximum accuracy, measure the connector several times and take an average of the readings.

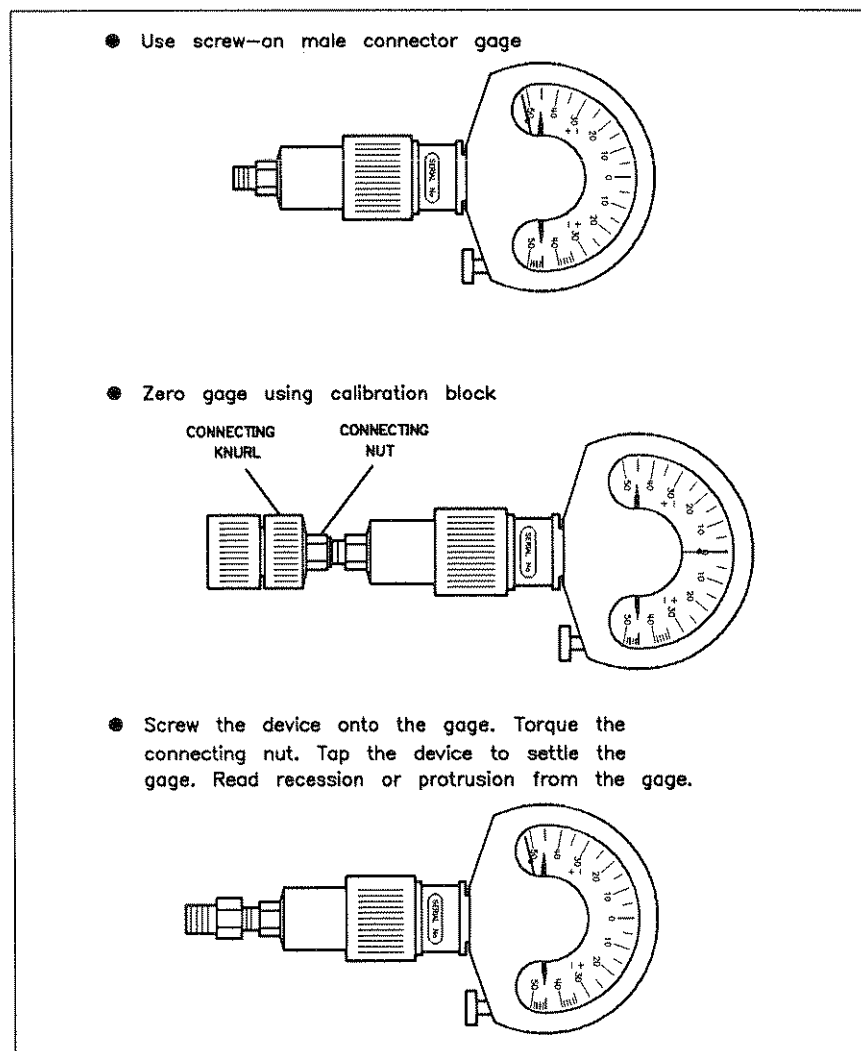

Figure 3-11.
Gaging an SMA Male Connector Using a Screw-on Type Gage

Female SMA (Push-on Type Gage)

1. Refer to Figure 3-12. Locate the female SMA connector gage (usually marked F).
2. Using the flat end of the gage calibration block (also usually marked F), zero the gage as described in the general procedure at the beginning of this chapter.
3. Measure the connector:
 - a. Carefully center and insert the gage into the connector; the gage plunger rests on the outer end of the female contact fingers.
 - b. Gently rock the connector gage within the connector to make sure the gage and the outer conductor mate flatly.
 - c. When the gage pointer settles consistently at a reading, read the gage indicator dial.

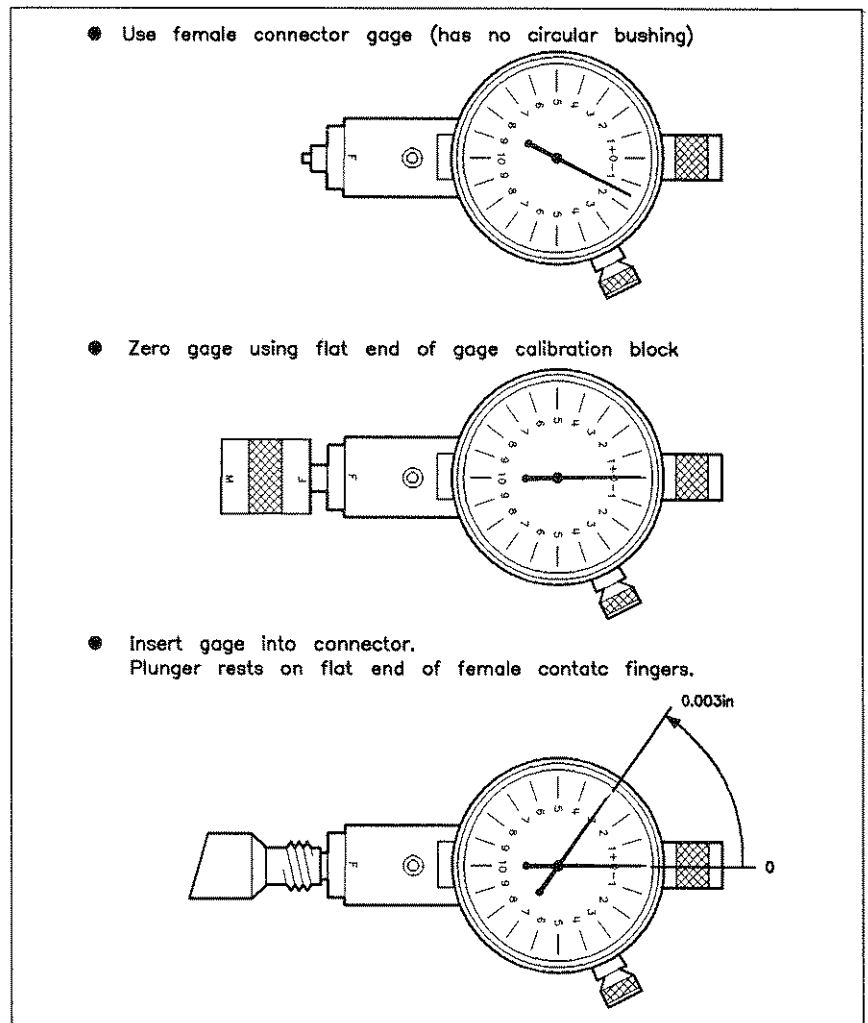

Figure 3-12.
Gaging an SMA Female Connector Using a Push-on Type Gage

Female SMA (Screw-on Type Gage)

1. Refer to Figure 3-13.
2. Use the steps in the general procedure at the beginning of this chapter to zero the gage.
3. Hold the gage by the barrel only and screw it on the connector, connecting the knurl (do not turn the gage or the device) finger-tight.
4. Torque the connector onto the gage to 56 N-cm (5 in-lb).
5. Tap the connector with your finger to settle the gage.
6. Read the gage indicator dial.
7. For maximum accuracy, measure the connector several times and take an average of the readings.

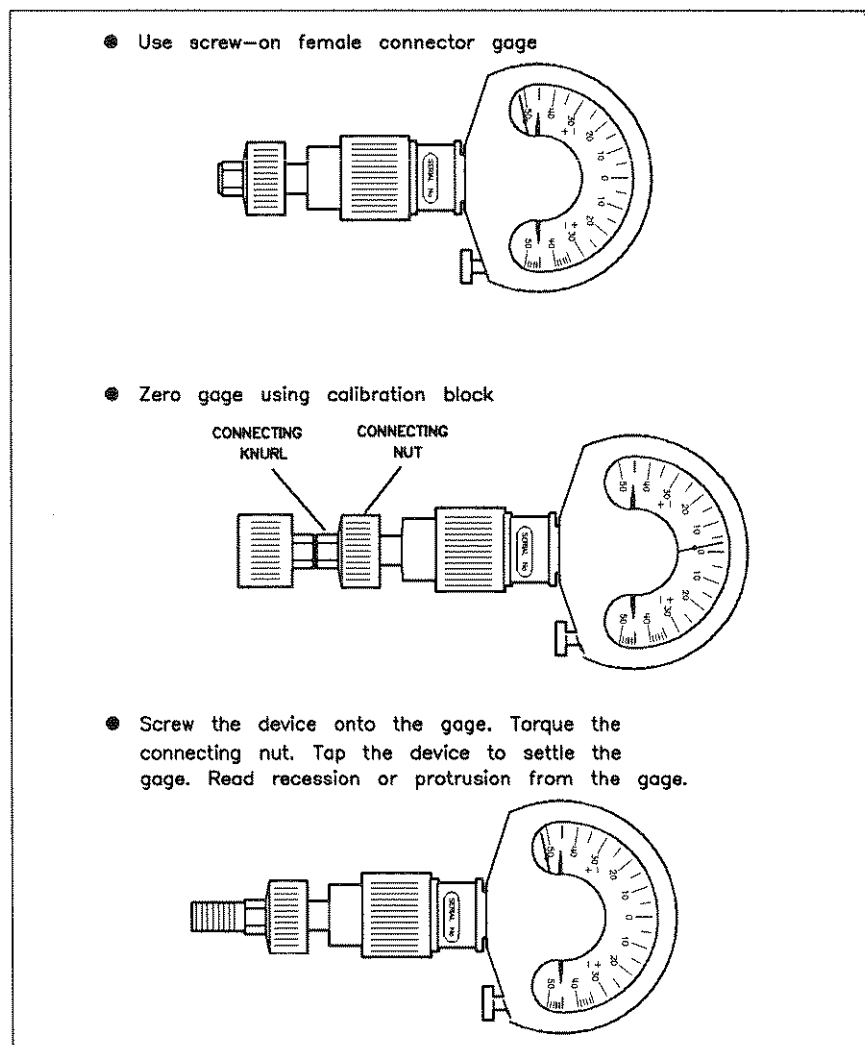

Figure 3-13.
Gaging an SMA Female Connector Using a Screw-on Type Gage

Precision 3.5 mm

Precision 3.5 mm connectors are sexed connectors. The male contact pin slides into the female contact fingers; the inside surfaces of the tip of the female contact fingers on the sides of the male contact pin provide electrical contact.

Specifications

- A maximum and minimum recession of the shoulder of the male contact pin.
- A maximum and minimum recession of the tip of the female center conductor behind the outer conductor mating plane.

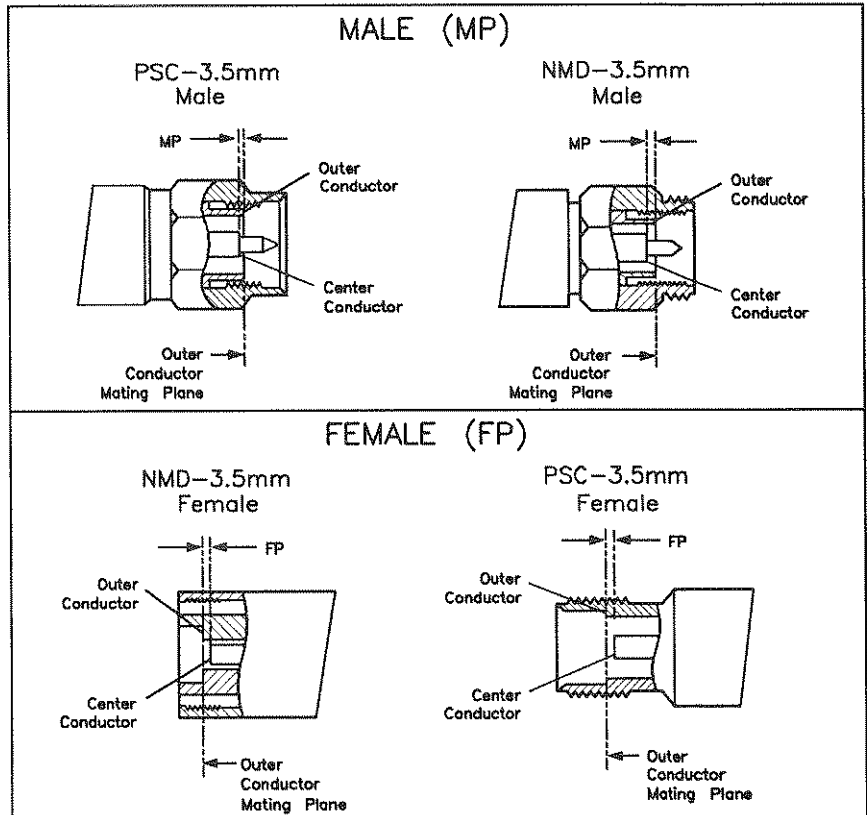

MP = male contact pin shoulder recession behind the outer conductor mating plane.

FP = recession of the end of female center pin behind the outer conductor mating plane.

Figure 3-14. 3.5 mm Connector Mechanical Specifications

Gaging Techniques

Male 3.5 mm (Push-on Type Gage)

1. Refer to Figure 3-15. The male 3.5 mm connector gage (usually marked M) has a circular metal bushing surrounding the gage plunger.
2. Use the protruding end of the gage calibration block (also usually marked M).
3. Slip the calibration block into the outer bushing so that the bushing comes to rest on the outer, flat area of the calibration block. When you measure a connector, the gage outer bushing rests on the outer conductor mating plane inside the connector.
4. Zero the gage as described in the general procedure at the beginning of this chapter.
5. Measure the connector:
 - a. Carefully center and insert the gage into the male connector; the flat outer part of the gage bushing rests on the outer conductor (the male contact pin slips into the hole in the gage plunger for this purpose).
 - b. Gently rock the connector gage within the connector to make sure the gage and the outer conductor mate flatly.
 - c. When the gage pointer settles consistently at a reading, read the gage indicator dial.

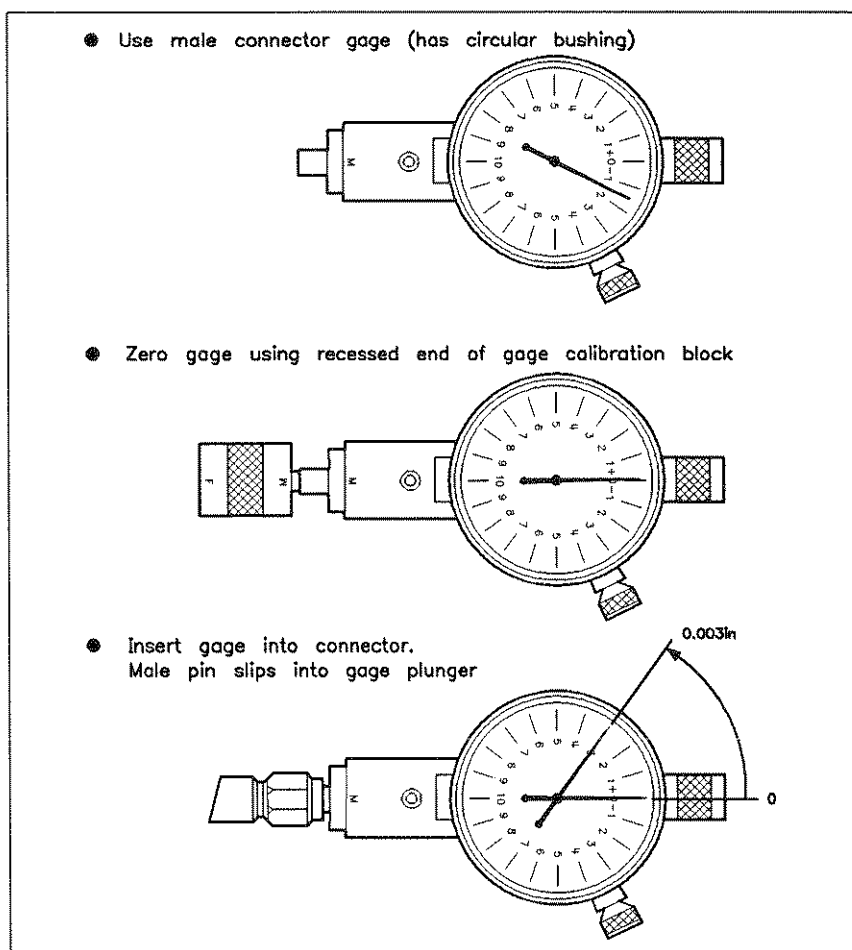

Figure 3-15.
Gaging a 3.5 mm Male Connector Using a Push-on Type Gage

**Male 3.5 mm
(Screw-on Type Gage)**

1. Refer to Figure 3-16.
2. Use the steps in the general procedure at the beginning of this chapter to zero the gage.
3. Hold the gage by the barrel only and screw it on the connector, connecting the knurl (do not turn the gage or the device) finger-tight.
4. Torque the connector onto the gage to 90 N-cm (8 in-lb).
5. Tap the connector with your finger to settle the gage.
6. Read the gage indicator dial.
7. For maximum accuracy, measure the connector several times and take an average of the readings.

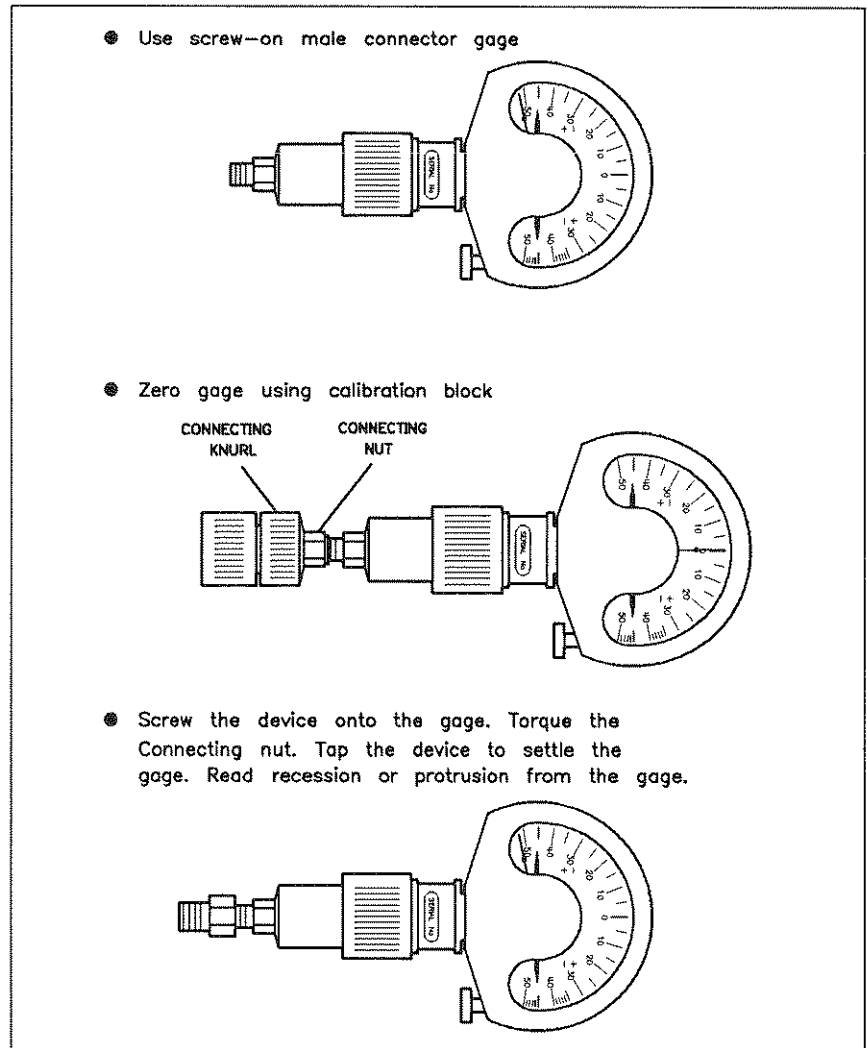

Figure 3-16.
Gaging a 3.5 mm Male Connector Using a Screw-on Type Gage

**Female 3.5 mm
(Push-on Type Gage)**

1. Refer to Figure 3-17. Find the female 3.5 mm connector gage (usually marked F).
2. Using the flat end of the gage calibration block (also usually marked F), zero the gage as described in the general procedure at the beginning of this chapter.
3. Measure the connector:
 - a. Carefully center and insert the gage into the connector; the gage plunger rests on the outer end of the female contact fingers.
 - b. Gently rock the connector gage within the connector to make sure the gage and the outer conductor mate flatly.
 - c. When the gage pointer settles consistently at a reading, read the gage indicator dial.

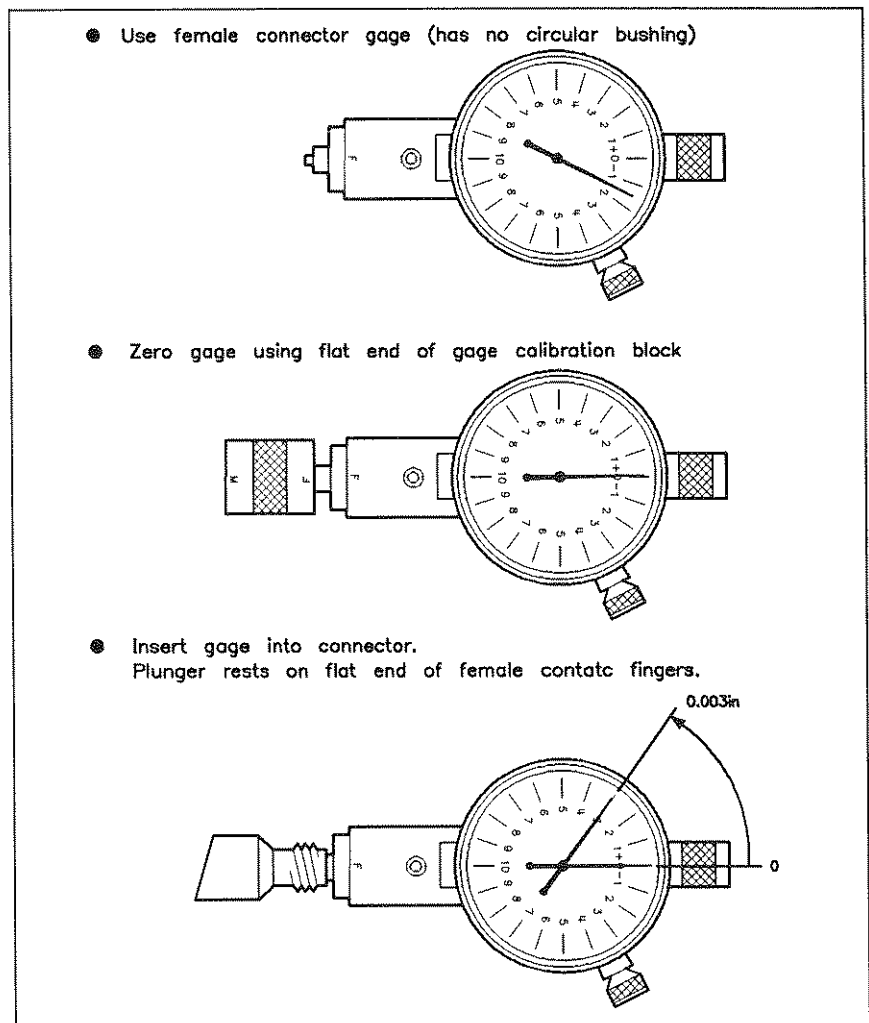

Figure 3-17.

Gaging a 3.5 mm Female Connector Using a Push-on Type Gage

**Female 3.5 mm
(Screw-on Type Gage)**

1. Refer to Figure 3-18.
2. Use the steps in the general procedure at the beginning of this chapter to zero the gage.
3. Hold the gage by the barrel only and screw it on the connector, connecting the knurl (do not turn the gage or the device) finger-tight.
4. Torque the connector onto the gage to 90 N-cm (8 in-lb).
5. Tap the connector with your finger to settle the gage.
6. Read the gage indicator dial.
7. For maximum accuracy, measure the connector several times and take an average of the readings.

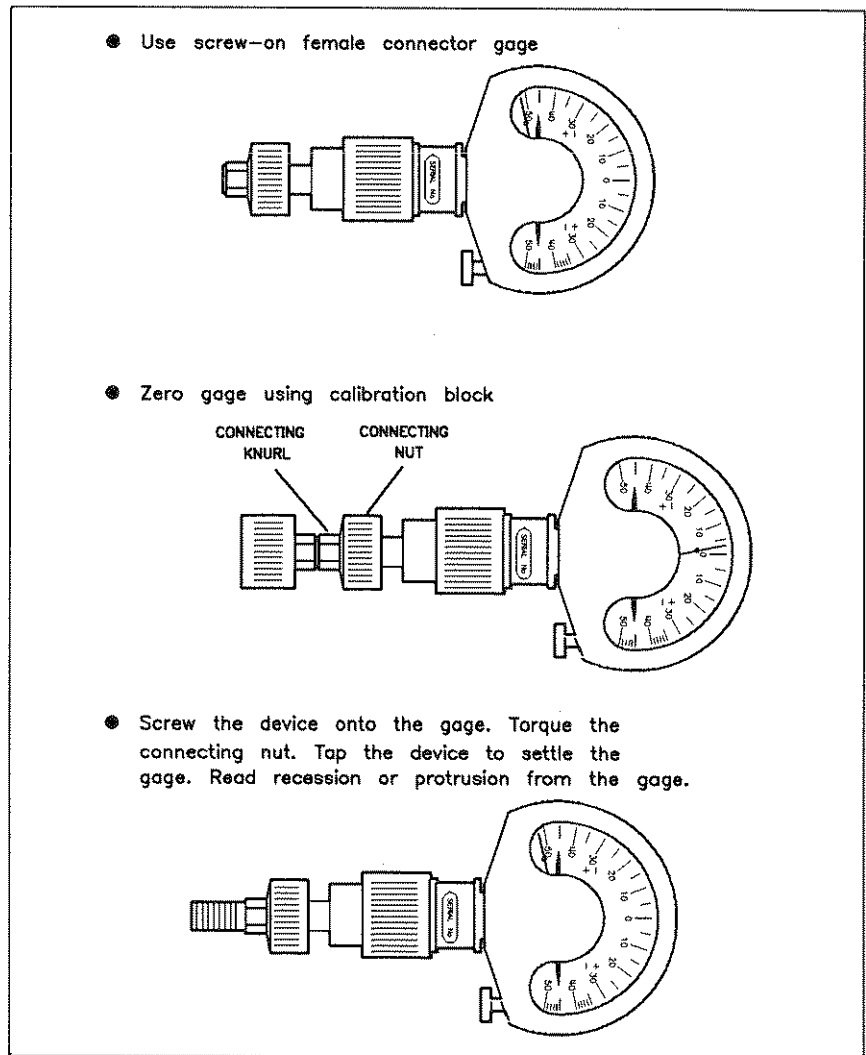
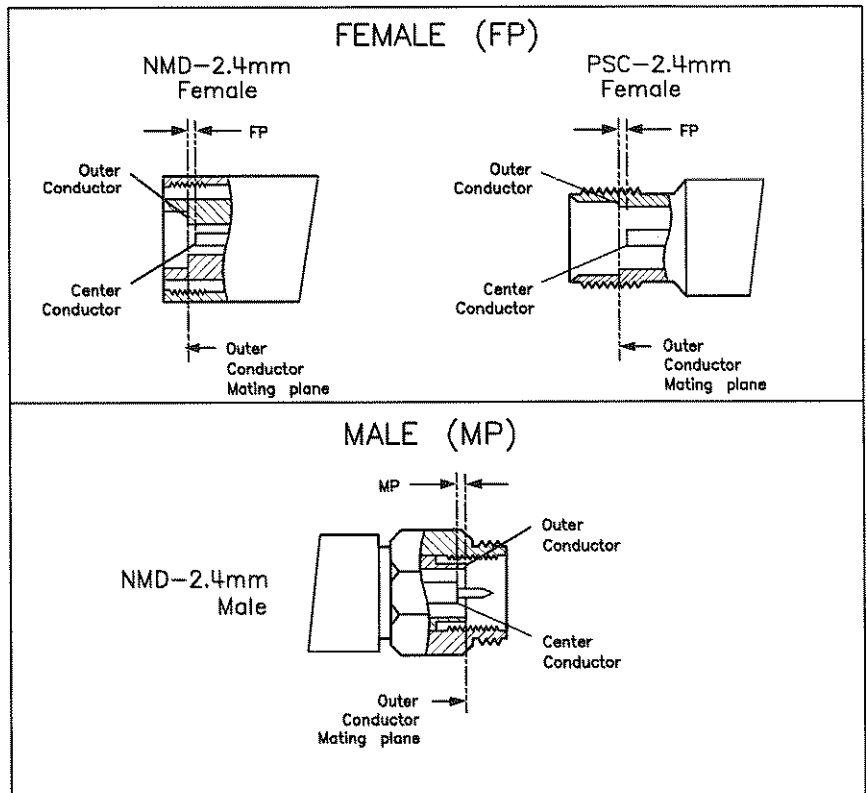

Figure 3-18.
Gaging a 3.5 mm Female Connector Using a Screw-on Type Gage

2.4 mm

Specifications

- A maximum and a minimum recession of the shoulder of the male contact pin.
- A maximum and a minimum recession of the end of the female center conductor behind the outer conductor mating plane.
- Neither the shoulder of the male contact pin nor of the tip of the female contact fingers may protrude in front of the outer conductor mating plane, and sometimes must *recede* minimally. Consult the mechanical specifications provided with your connector or device.
- The maximum allowable recession depends on the connector and the device. Consult the mechanical specifications provided with the connector or the device itself.



MP = male contact pin shoulder recession behind the outer conductor mating plane.

FP = recession of the end of female center pin behind the outer conductor mating plane.

Figure 3-19. 2.4 mm Connector Mechanical Specifications

Gaging Techniques

Male 2.4 mm Connectors

1. Refer to Figure 3-20 Using the male calibration block, zero the gage as described in the general procedure at the beginning of this chapter.
2. Hold the gage by the barrel only and screw it on the connector, connecting the knurl (do not turn the gage or the device) finger-tight.
3. Torque the connector onto the gage to 90 N-cm (8 in-lb).
4. Tap the connector with your finger to settle the gage.
5. Read the gage indicator dial.
6. For maximum accuracy, measure the connector several times and take an average of the readings.

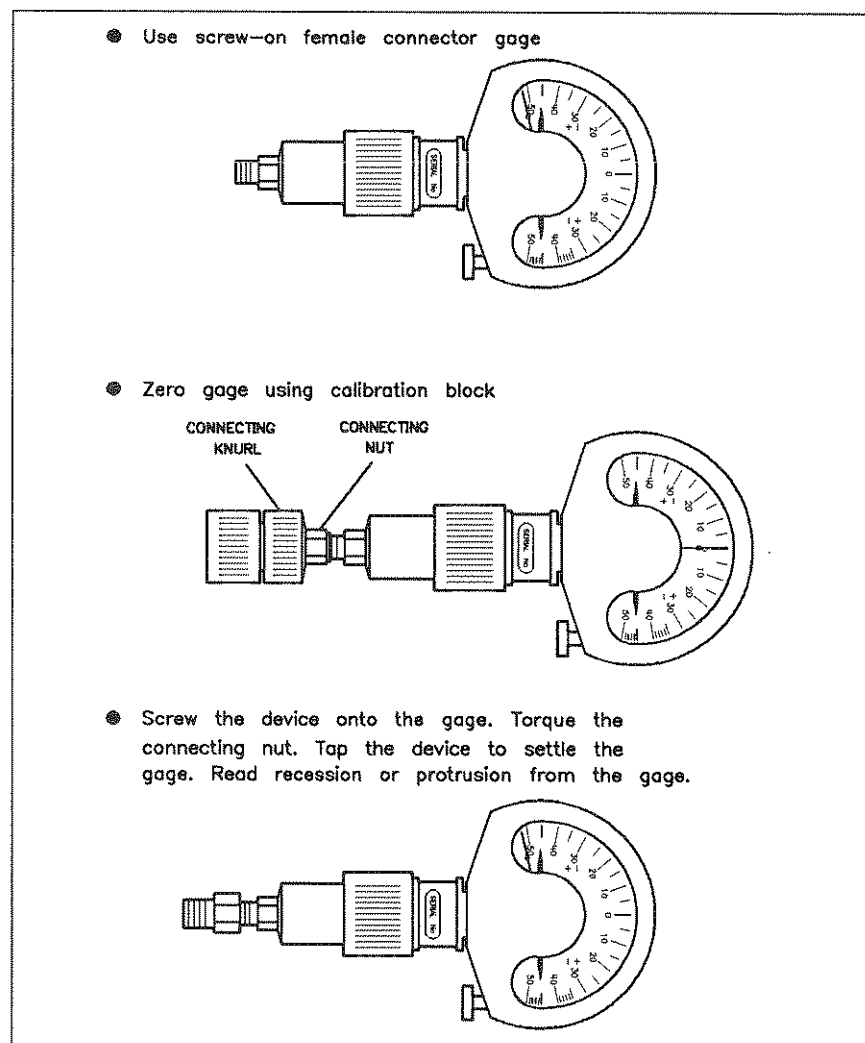

Figure 3-20. Gaging a 2.4 mm Male Connector

Female 2.4 mm Connectors

1. Refer to Figure 3-21 Using the female calibration block, zero the gage as described in the general procedure at the beginning of this chapter.
2. Hold the gage by the barrel only and screw it on the connector, connecting the knurl (do not turn the gage or the device) finger-tight.
3. Torque the connector onto the gage to 90 N-cm (8 in-lb).
4. Tap the connector with your finger to settle the gage.
5. Read the gage indicator dial.
6. For maximum accuracy, measure the connector several times and take an average of the readings.

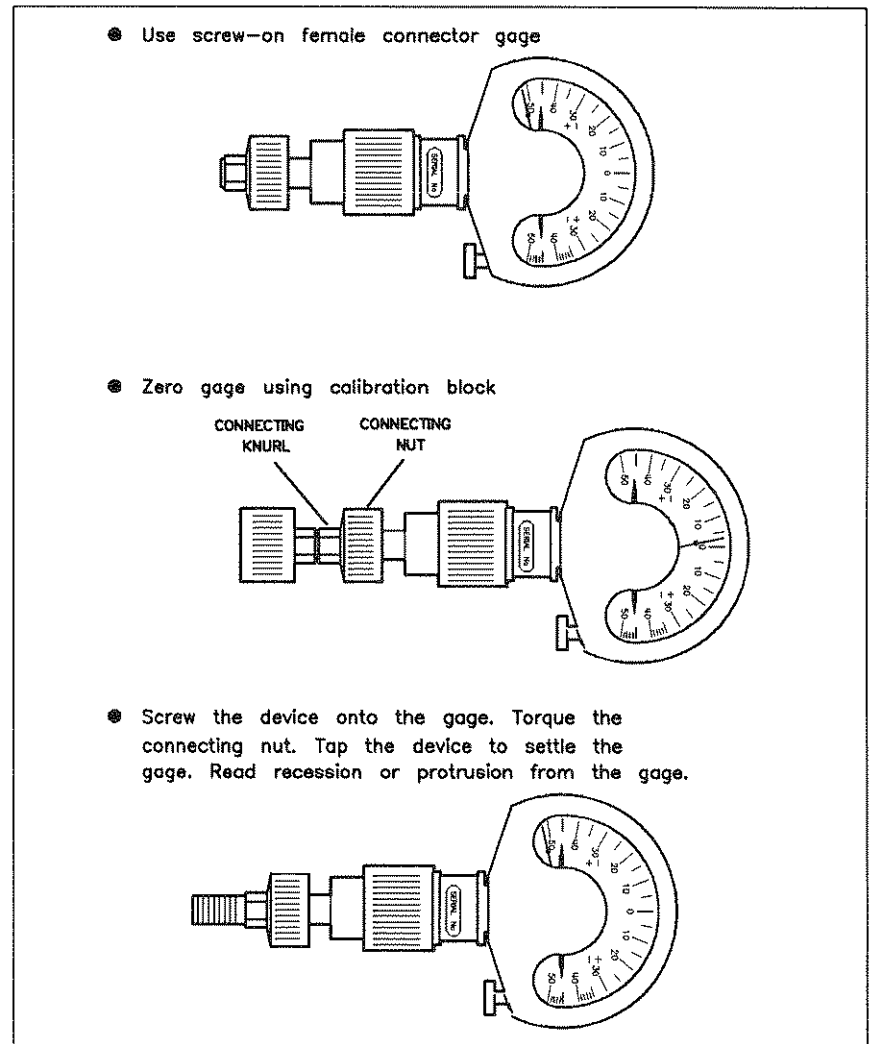

Figure 3-21. Gaging a 2.4 mm Female Connector

Making Connections

Good connections require a skilled operator. Because of instrument sensitivity and coaxial connector mechanical tolerances, slight errors in operator technique can significantly effect measurements and measurement uncertainties.

Note



Before you make *any* connections, clean and inspect (visually and mechanically) all connectors.

General Connecting Procedure

Connecting

The following procedure uses a 7 mm fixed load and a 7 mm test port connector, but the steps and principles are the same for all coaxial connector types. Read this general procedure, then read any information that applies specifically to your connector type.

Caution



This procedure assumes that you have taken the necessary ESD precautions, and have *already* inspected (visually and mechanically) and cleaned the connectors.

1. Carefully align the connectors (see Figure 3-22).
 - a. Fully extend the connector sleeve on one of the connectors and fully retract the sleeve on the other. The extended sleeve creates a cylinder into which the second connector fits. If one of the connectors is fixed (as on a test port) fully extend *that* connector sleeve (spin its knurled connector nut to make sure the threads are fully extended). Fully retract the connector sleeve on the other connector.
 - b. As you bring one connector up to the other, and as you make the actual connection, be sure the connectors align perfectly. If not, stop and begin again.

On sexed connectors, the male connector center pin must slip concentrically into the contact fingers of the female connector.

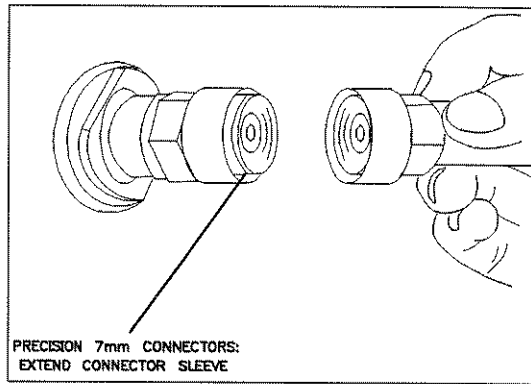

Figure 3-22. Align the Connectors

2. Push the connectors straight together. *Do not* twist or screw them together. As the center conductors mate, you may feel a slight resistance.
3. Engage the connector nut over the threads on the second connector. Turn *only* the connector nut. Let the connector nut pull the two connectors straight together (see Figure 3-23).

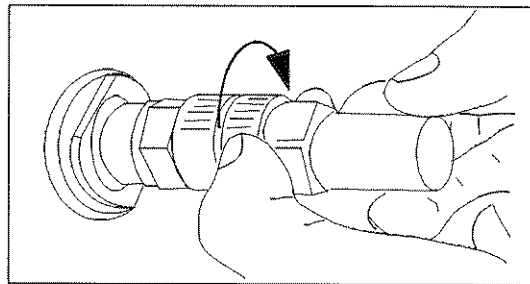

Figure 3-23. Make the Preliminary Connection Gently

Caution



Do *not* twist one connector into the other (like changing a light bulb). This happens if you turn the device body rather than the connector nut.

In a preliminary connection, the mating plane surfaces make uniform, light contact. Do not overtighten this connection.

At this point you want a connection in which the outer conductors make gentle contact at all points on both mating surfaces. This requires very light finger pressure (no more than 2 inch-pounds of torque).

4. Relieve any side pressure on the connection from long or heavy devices or cables. This assures consistent torque in the following steps.

5. Use a torque wrench to make the final connection (Figure 3-24).

Using a torque wrench prevents overtightening (and possible connector damage). It also guarantees that all connections are equally tight each time.

- a. Prevent the rotation of anything other than the connector nut you wish to tighten. Do this by hand for a fixed connector (as on a test port). Otherwise, use an open-end wrench to keep the body of the connector from turning.

- b. Hold the torque wrench lightly.

Hold the torque wrench at the same point near the end of the handle each time you use it. Always use the wrench in the proper orientation (see Figure 3-25), and when possible, hold the wrench horizontally as you begin tightening the connection.

- c. Apply force at the *end* of the torque wrench, perpendicular to the wrench, in a plane parallel to the outer conductor mating planes. This applies torque to the connection *through* the wrench.

Do not hold the wrench so tightly that you push the handle straight down along its length rather than pivoting it (Figure 3-26). If you do, you apply an unlimited amount of torque.

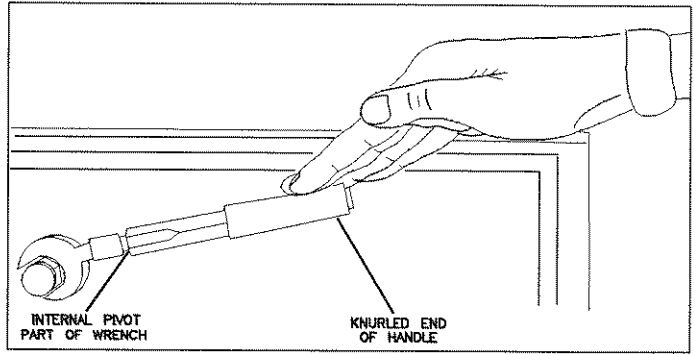

Figure 3-24. Make the Final Connection With a Torque Wrench

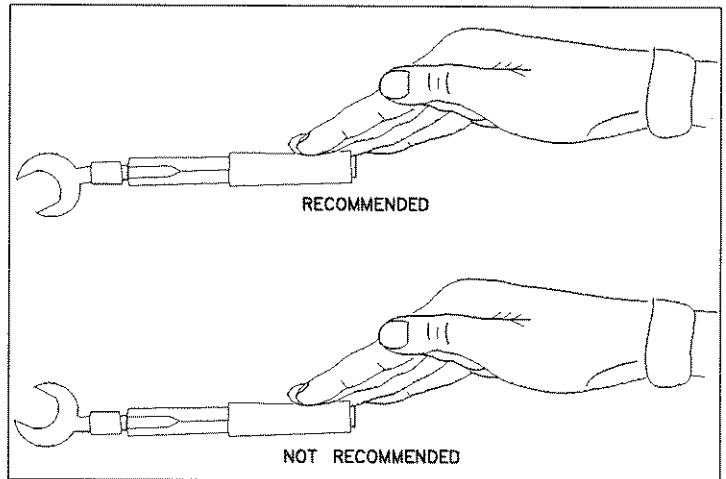

Figure 3-25. Proper Torque Wrench Orientation

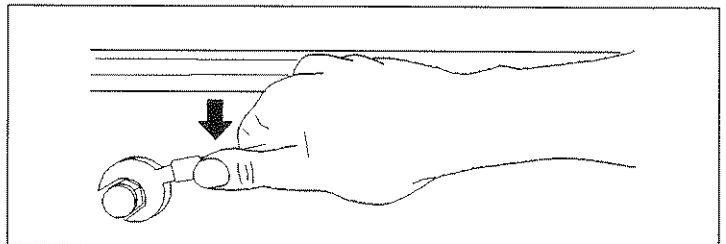

Figure 3-26. Do not Push the Torque Wrench Straight Down

- d. Tighten the connection just to the torque wrench “break” point (the wrench handle gives way at its internal pivot point. See Figure 3-27). *Do not* tighten the connection further.

cautions



You don't have to “fully break” the handle of the torque wrench to reach the specified torque, and doing so can cause the handle to kick back and loosen the connection.

Do not pivot the wrench handle on your thumb or other fingers (Figure 3-28). If you do, you apply an unknown amount of torque to the connection when the wrench reaches its “break” point.

Do not twist the head of the wrench relative to the outer conductor mating plane. If you do, you apply more than the recommended torque.

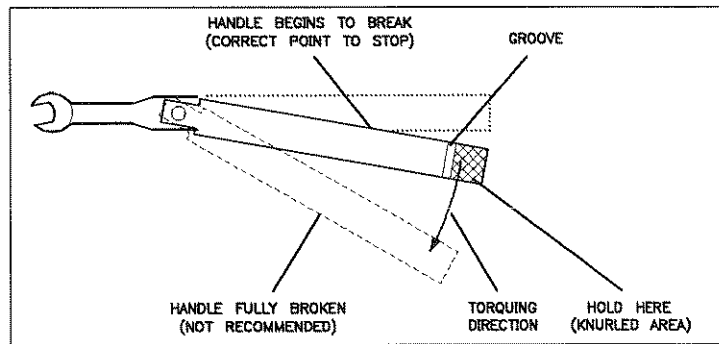

Figure 3-27. Tighten Only to the Torque Wrench Break Point

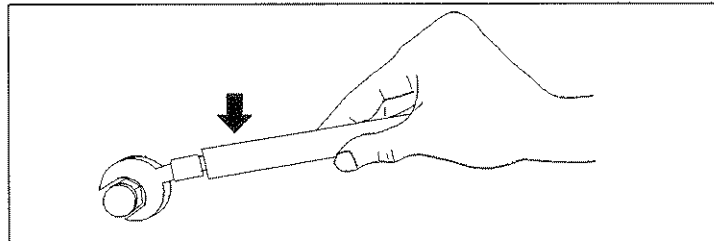

Figure 3-28. Do Not Pivot the Torque Wrench on Your Thumb

Disconnecting

Note



To avoid lateral (bending) force on the connector mating plane surfaces, always support the devices and connections.

1. Firmly grasp the device body (to prevent it from turning).
2. Loosen the connector nut that you tightened to make the connection.

If necessary, use the torque wrench or an open-end wrench to start the disconnection, but leave the connection finger tight.

3. Complete the disconnection by hand, turning only the connector nut.
4. For sexed connectors, pull the connectors straight apart.

Caution



Do not twist the connection or you may damage the center conductors or the interior component parts to which the connectors attach. You can also scrape the plating off the male contact pin, or (rarely) slightly unscrew the male or female contact pin from its interior mounting, taking it out of specification.

Precision 7 mm

Seating

The general procedure in this chapter describes how to connect a precision 7 mm connector. In certain applications, however, an additional step may prove helpful. Use the following procedure only for the most demanding measurement applications, and only with gold-plated precision 7 mm connectors.

1. After making the preliminary connection (using light finger pressure), hold the connector nut stationary with one hand. With the other hand, gently turn *the body of the connecting device* 5 to 15 degrees opposite the direction of tightening (Figure 3-29). You should feel smooth, uniform movement, without resistance.

You may feel a sudden, slight “breaking loose” of the connection when you rotate the connected device. This happens as the mating plane surfaces or the connector nut threads move into correct alignment, and it slightly loosens the connector nut.

2. If the connector nut loosens, tighten it slightly and repeat the rotation. You should feel smooth, uniform motion, without resistance.
3. Use a torque wrench to make the final connection (136 N-cm (12 in-lb)).

Caution



Because this technique does wear the gold plating on the mating plane surfaces, use seating only in the most demanding measurement applications. Never use this seating technique as a substitute for careful cleaning and complete mechanical inspection.

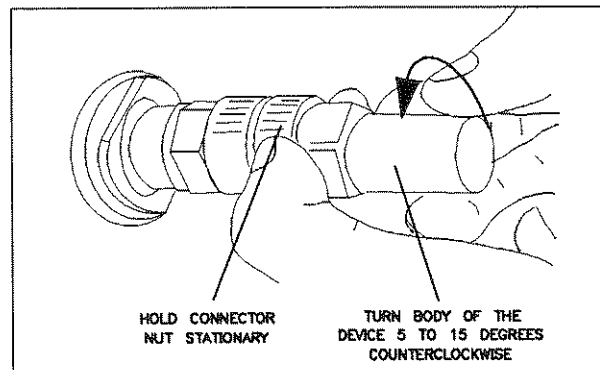

Figure 3-29. Seating a Precision 7 mm Connector

Type-N

For proper torque, finger-tighten a type-N connector (these connectors do not have wrench flats).

If you wish, you can use a torque wrench with a special non-slip end (136 N-cm (12 in-lb)).

Never rotate the mating plane surfaces against each other.

3.5 mm

Mating a Precision 3.5 mm Connector to an SMA Connector

For proper torque, finger-tighten this type of connector.

Using the following procedure *very carefully*, you can mate a precision 3.5 mm connector to an SMA connector (Figure 3-30). The two connectors have slightly different dimensions and mechanical characteristics. Mating a precision 3.5 mm connector to an SMA connector also affects electrical performance (see “Electrical Performance”).

1. Gage both connectors. The SMA connector must meet the precision 3.5 mm connector setback specifications. If not, it will damage the 3.5 mm connector.
2. Carefully align the connectors.
3. Push the two connectors straight together, with the male contact pin precisely concentric with the female.
4. Do not twist either connector or device.
5. Turn only the outer male connector nut.
6. Use a torque wrench for the final connection (56 N-cm (5 lb-in)).

If you must make more than a few connections, use a 3.5 mm-to-3.5 mm adapter to protect the 3.5 mm connector (see Appendix B).

Electrical Performance

The junction of two precision 3.5 mm connectors provides superior electrical performance compared to either the junction of two SMA connectors, or an SMA connector mated to a precision 3.5 mm connector (see Figure 3-31).

When you mate an SMA connector with a precision 3.5 mm connector, the connection has a typical mismatch (SWR) of 1.10 at 2 GHz (less than that of two SMA connectors, but much greater than that of two precision 3.5 mm connectors).

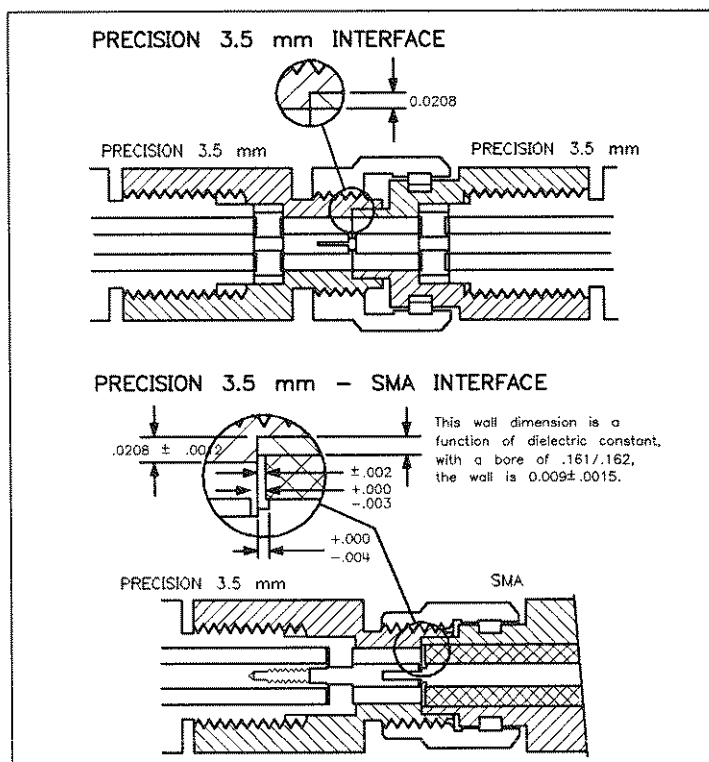

Figure 3-30.
A Precision 3.5 mm Connector Interface Compared to
A Precision 3.5 mm-to-SMA Connector Interface

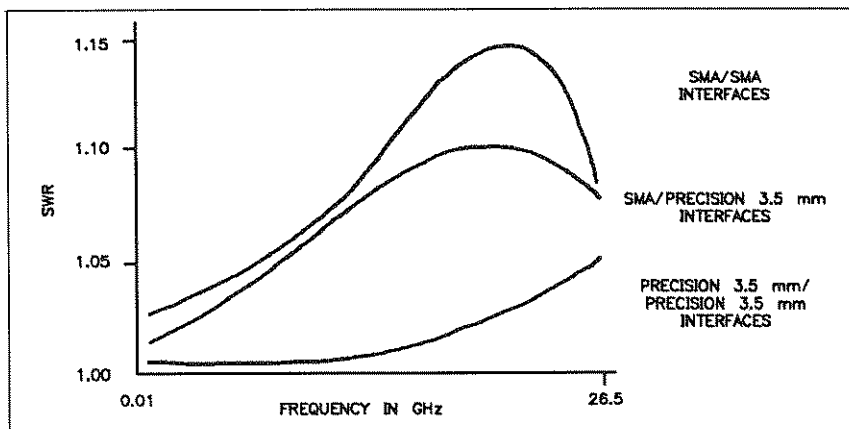

Figure 3-31.
Typical SWR of SMA and Precision 3.5 mm Coupled Junctions

2.4 mm

2.4 mm

For proper torque, finger-tighten this type of connector.



Removing, Inspecting, & Replacing Center Conductor Collets

Collet Types

Slotted (page A-2)

This appendix covers two types of slotted 7 mm collets:

- 4-slot collets.
- 6-slot collets.

The more durable 6-slot collets provide more repeatable connections. Never replace a 6-slot collet with a 4-slot collet. You can reuse either type, but inspect them carefully before you do.

Slotless (page A-4)

This appendix covers two types of slotless collets:

- 3.5 mm slotless collets.
- 7 mm slotless collets.

Slotted Collets

Removing a Center Slotted Collet

Use this procedure to remove a slotted center conductor collet for any of the following reasons:

- You wish to gage the connector with the collet removed.
- You find a damaged collet.
- The collet protrusion measures out of specification.

1. Wear a grounded wrist strap, and ground yourself as far as possible from the test port.
2. To open the interior collet removal jaws fully, pull back the handle of the collet removing tool.
3. With the handle pulled back, carefully insert the tool completely into the connector, inside the outer conductor, until it comes to rest lightly on the interior support bead (Figure A-1).
4. Release the handle and remove the tool (and collet) from the connector.

Note



Removing the collet should not damage it. If it does, replace the collet and the collet removing tool.

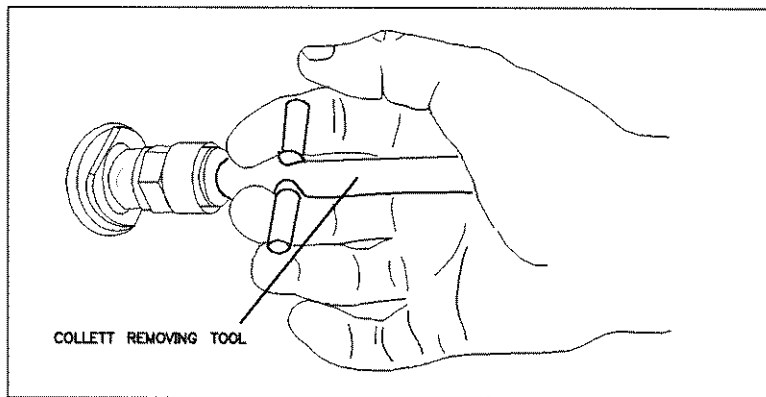

Figure A-1. Using the Collet Removal Tool

Inspecting a Slotted Collet

- Look for edge or surface damage.
- Look for any signs of bent or twisted spring contacts. If necessary, replace both the collet and the collet removing tool.

Replacing a Slotted Collet

1. Wear a grounded wrist strap, and ground yourself as far as possible from the test port. .
2. With tweezers, pick up the collet by the slotted end.
3. Carefully insert the collet (narrow end first) into the connector center conductor (Figure A-2).

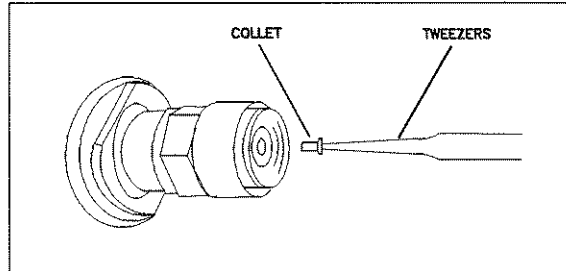

Figure A-2. Inserting a Collet

4. Using a blunt plastic rod (or the rounded plastic handle of the collet removing tool) press the collet gently until it snaps into place (Figure A-3).

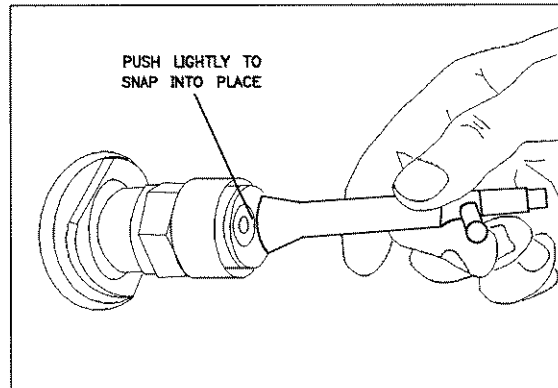

Figure A-3. Gently Press the Collet into Place

Slotless Collets

When properly used, a precision slotless connector should have the same lifespan as a standard slotted connector. Hewlett-Packard designed the precision slotless contacts to mate with all connectors within a connector series *when those connectors meet published interface dimensions*. Mating a connector that *does not* meet published specifications can damage a precision slotless connector. For this reason, ensure that any device you connect measures within its specifications.

The following procedure calls for items contained in HP 85052B option K11 and 85054B option K11 slotless contact repair kits:

- Alcohol.
- Foam swabs.
- Tweezers.
- Inner contact removal tool.
- Inner contact insertion tool.
- Inner contact testing tool.
- Testing weight.
- Replacement inner contacts.

HP 85052B Option K11

Use the 3.5 mm slotless contact repair kit to repair the female contacts on all HP PSC-3.5 mm connectors except for the precision slotless contacts on the air lines in the HP 85052C 3.5 mm precision calibration kit. If damaged, these contacts must be repaired at the factory.

HP 85054B Option K11

Use the type-N slotless contact repair kit to repair the female contacts on all HP type-N precision slotless connectors.

Repairing A Slotless Contact

If you suspect a problem with the slotless contact, make a visual inspection to check for damage. As you use a connector, dirt and metal particles can accumulate in and around the slotless contact. In extreme cases this accumulation can render the contact non-functional. Often, simply cleaning the contact fixes the problem.

This section provides procedures on how to clean both the inner contact and the center conductor, how to reinstall the inner contact, how to test for functionality, and, if necessary, how to replace the inner contact.

Repairing a damaged slotless contact comprises six-steps:

1. Gage the connector.
2. Under $\geq x10$ magnification, inspect the connector to determine the damage.
3. Remove the damaged inner contact.
4. Inspect the center conductor. If undamaged, clean it.
5. Install the replacement inner contact.
6. Test the slotless contact.

Slotless

Inspecting A Damaged Slotless Contact

Inspect the contact under $\geq x10$ magnification to define the problem. Usually you can make the repair without disassembling the device to which the precision slotless contact is attached.

Inspect the slotless contact to see if any of the following conditions exist:

- The inner contact has one or more fingers bent inward or crushed, preventing proper contact to the male pin (see Figure A-4).
If so, go to step 1 of "Removing A Slotless Contact".
- The inner contact has one or more fingers broken (see Figure A-5).
If so, go to step 2 of "Removing A Slotless Contact".
- The inner contact is pushed inside the center conductor and does not make contact with the mating connector's male pin (see Figure A-6).
If so, go to step 3 of "Removing A Slotless Contact".
- The end of the center conductor appears dented or scraped near where it touches the inner contact (see Figure A-7).

If so, the slotless contact may be damaged beyond the capabilities of this repair kit, and the device must be repaired or replaced by Hewlett-Packard.

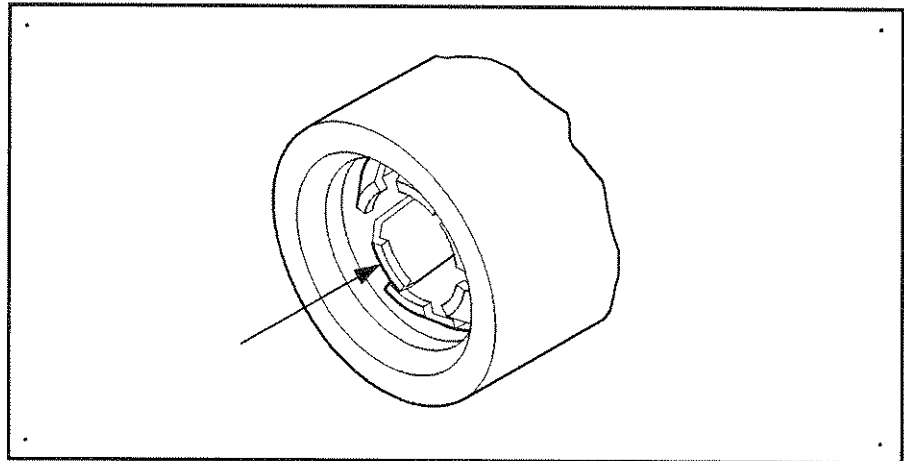

Figure A-4. Finger Bent In or Crushed

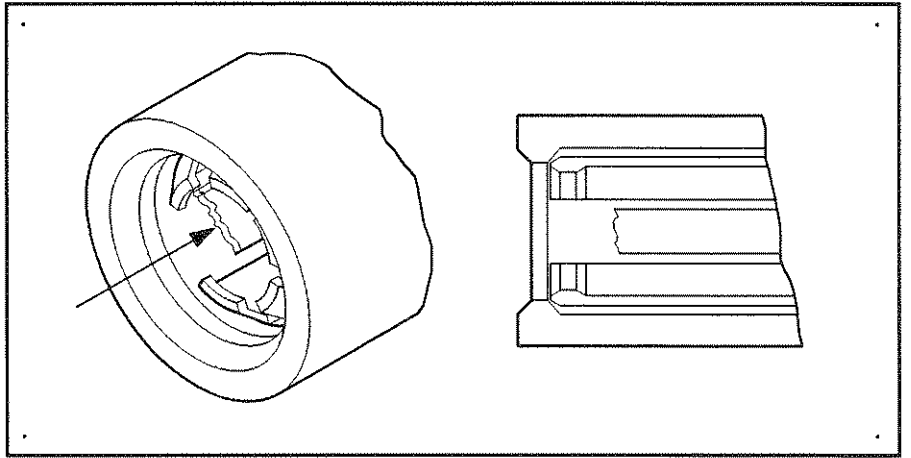

Figure A-5. Broken Inner Contact

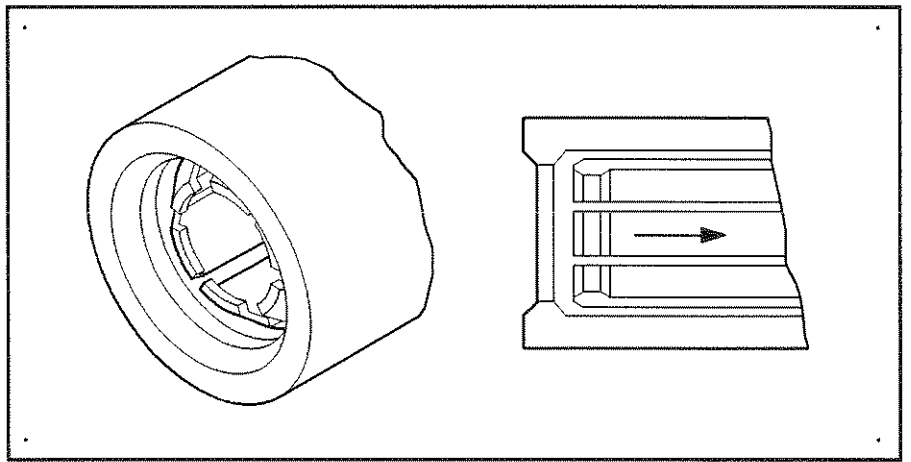

Figure A-6. Inner Contact Pushed Inside

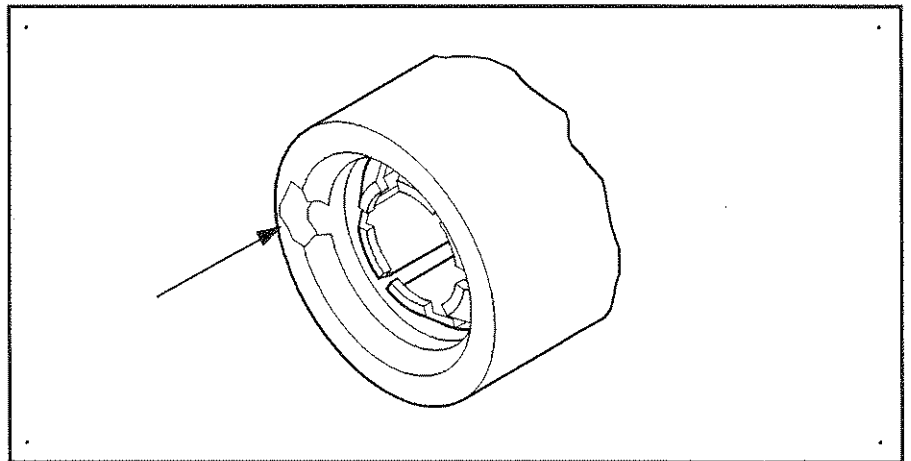

Figure A-7. Damaged Center Conductor

Removing A Slotless Contact

Step 1

If one or more of the inner contact's fingers are bent inward or crushed, you must straighten or remove those fingers before you remove the entire inner contact. Figure A-8 shows both the inner contact and the center conductor.

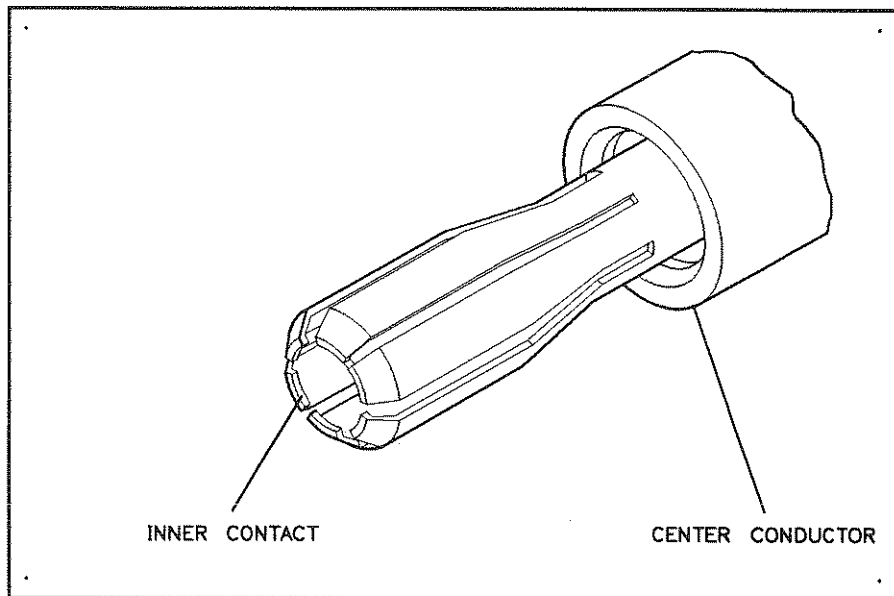

Figure A-8. The Inner Contact and Center Conductor

- a. Under magnification, *carefully* try to insert the removal tool (see Figure A-9).
- b. If the damaged fingers prevent you from inserting the tool, use tweezers to either move aside or remove the damaged fingers (see Figure A-10).

Be *extremely cautious* to avoid damaging the center conductor, which houses the inner contact. Do not touch the tweezers to anything but the damaged inner contact. Do not, under any circumstances, use anything to squeeze or clamp on to the center conductor that might cause damage.

- c. After you move or remove the damaged inner contact fingers and can insert the inner contact removal tool, go to step 3.

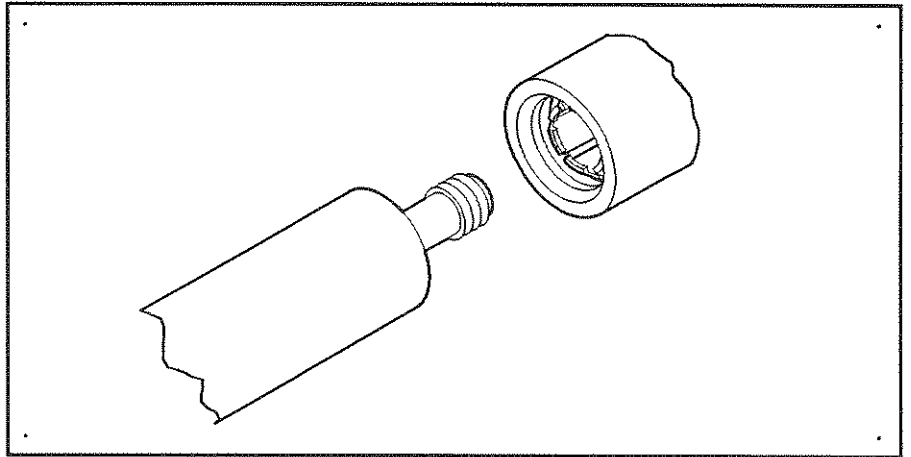

Figure A-9. Inserting the Removal Tool

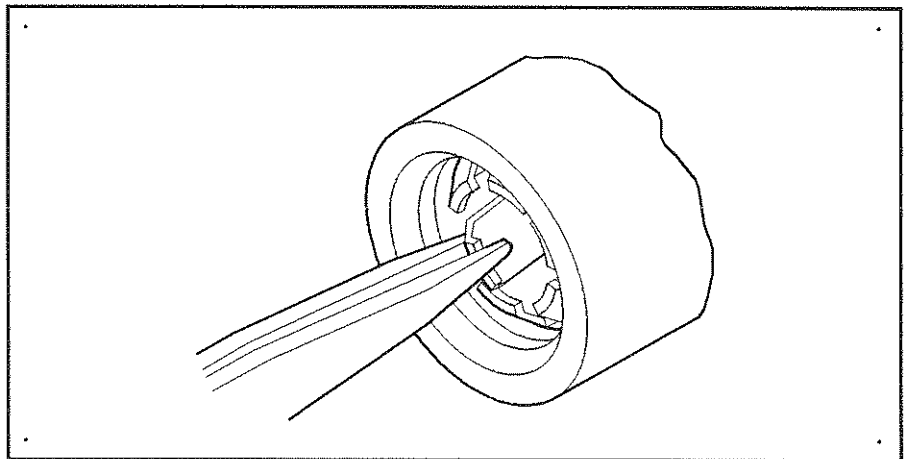

Figure A-10. Moving a Damaged Finger

Step 2

If one or more of the inner contact's fingers are broken, you must remove that finger before you remove the entire inner contact:

- a. Under magnification, look down inside the inner contact and locate the broken finger or fingers.

The fingers may have already fallen out. If so, continue with step 3.

- b. If you can see the broken fingers inside the inner contact, turn the device upside down and gently tap on it (see Figure A-11).

Using this gentle tapping, try to force the broken fingers to drop out or at least move forward far enough so that you can remove them with the tweezers (see Figure A-12). Do not, under any circumstances, use anything other than gentle tapping.

- c. After you remove the broken inner contact fingers and can carefully insert the inner contact removal tool, go to step 3.

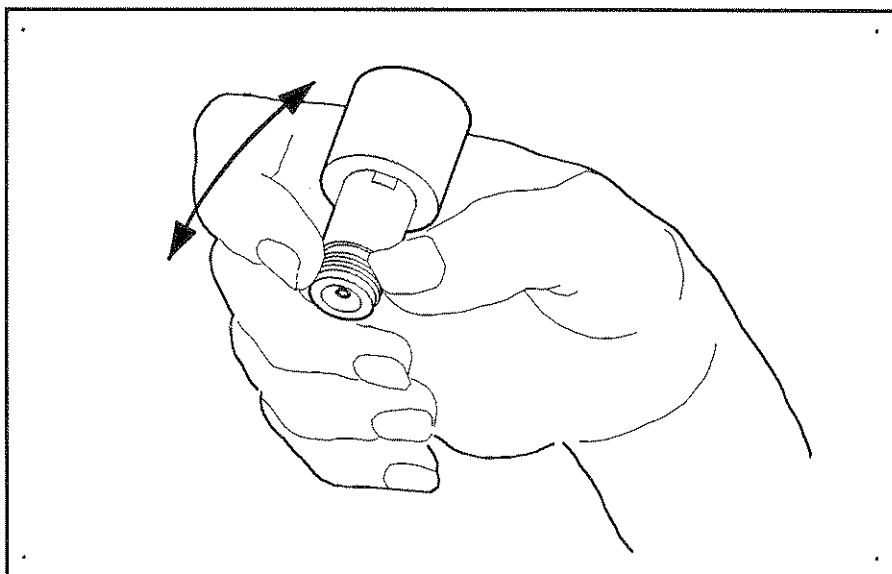

Figure A-11. Freeing a Broken Contact Finger

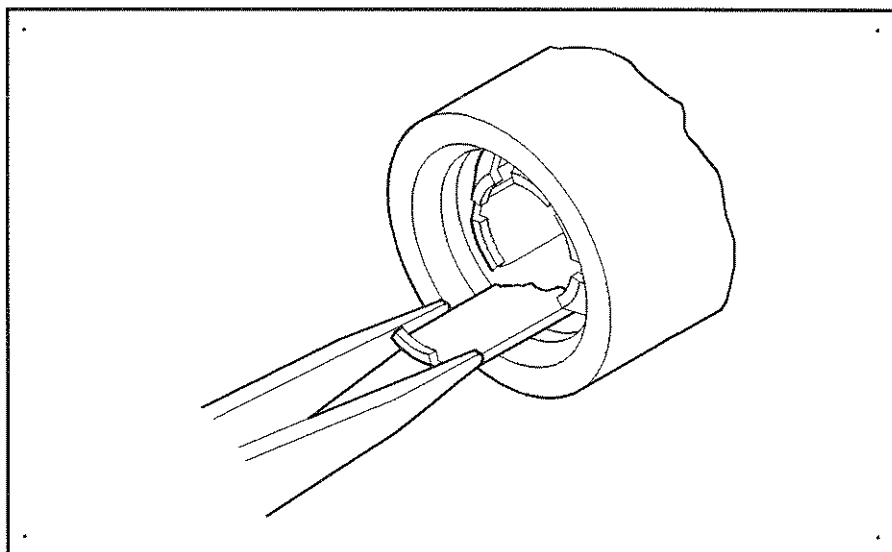

Figure A-12. Removing a Broken Contact Finger

Step 3

If the inner contact is pushed inward and no longer makes contact with the mating connector's male pin, you must remove and replace the inner contact:

- a. Under magnification, insert the removal tool into the damaged contact far enough so that it touches the bottom of the inside of the inner contact.
- b. Turn the tool clockwise to engage the tool coupling thread with the thread on the inside of the contact (see Figure A-13).
- c. Occasionally the inner contact spins with the tool, preventing the tool from engaging. If this happens, apply a small amount axial pressure to the tool and continue to turn it clockwise.
- d. Once you engage the tool by 2 turns, you can remove the inner contact. Pull the tool and inner contact straight out away from the center conductor (see Figure A-14).

Caution



Do not damage the center conductor as you remove the inner contact.

- e. Unthread the broken inner contact from the removal tool and discard the contact; it cannot be repaired or reused.

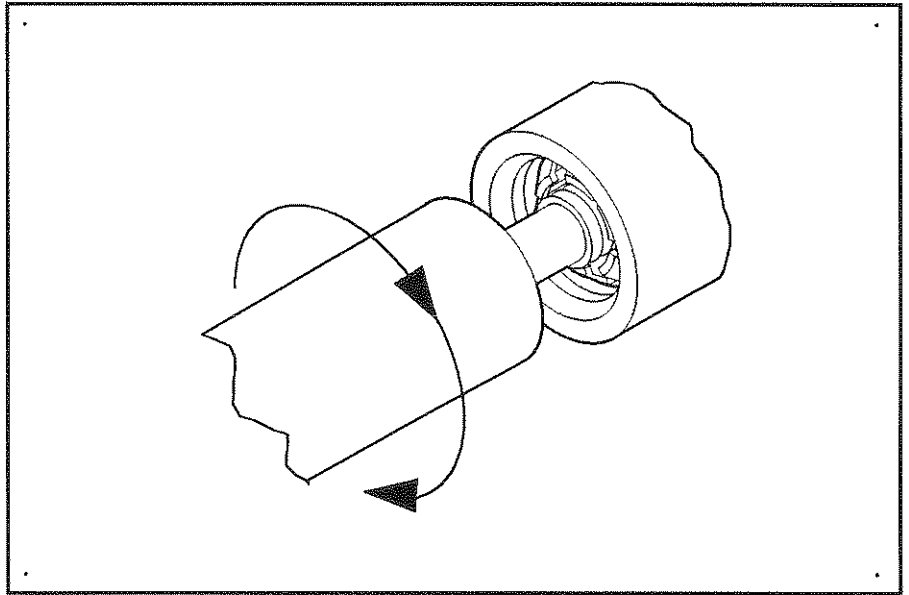

Figure A-13.
Threading the Removal Tool into
the Inner Contact

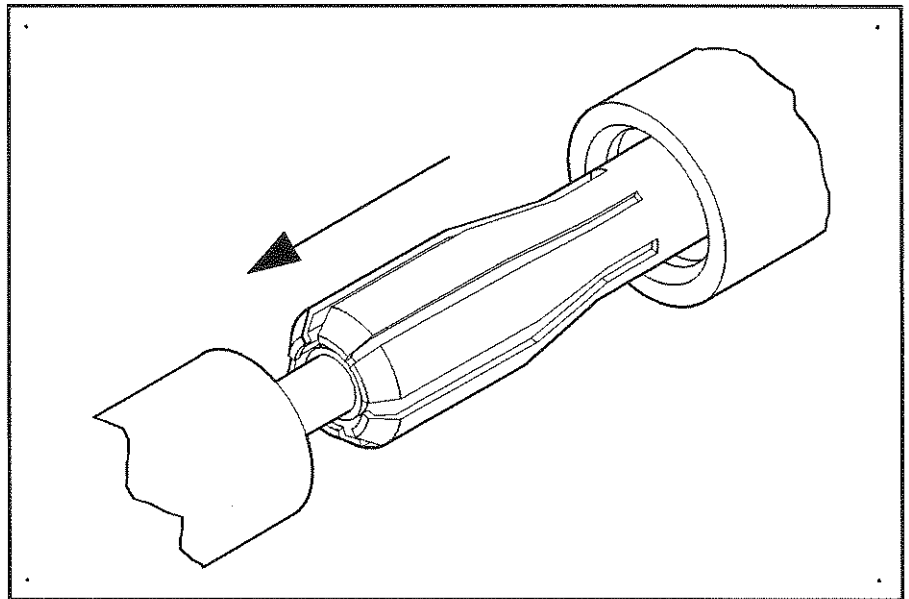

Figure A-14. Removing the Inner Contact

Slotless

A-14 Collet

Inspecting & Cleaning A Center Conductor

Inspecting

1. Under magnification, inspect the center conductor for damage.
2. Refer to Figure A-15. Is the center conductor gouged? Does it have any imperfection that would interfere with the insertion of a new inner contact? If so, you must return the device to Hewlett-Packard for repair; you cannot repair a center conductor with either kit.
3. If the center conductor is undamaged, or if the damage is too light to affect device performance, clean the center conductor.

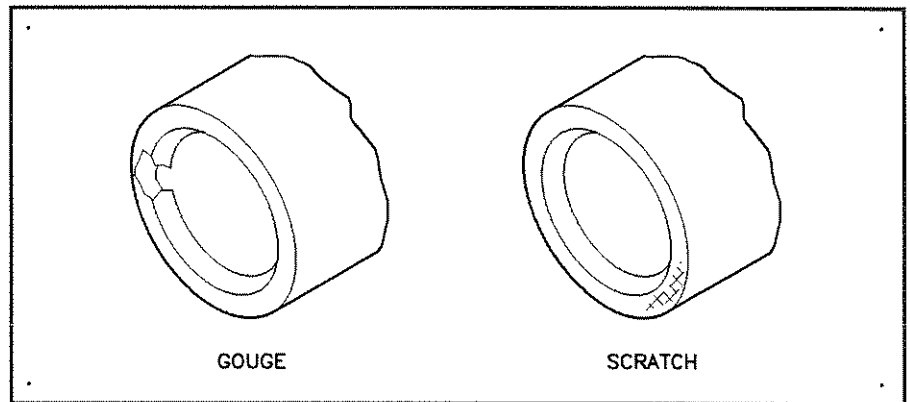

Figure A-15. Damaged Center Conductor

Cleaning

1. Under magnification, look for loose dirt or metal particles.
2. Using foam swabs and isopropyl alcohol, clean the center conductor.
3. Using a source of dry air or nitrogen, blow out the hole in the center conductor; be sure that all the alcohol evaporates.
4. Now you can insert a new inner contact into the clean center conductor.

Inserting an Inner Contact

When you install a replacement inner contact, be careful handling the replacement parts. These parts are fragile until they are inside the center conductor; do not squeeze or misuse them in any way.

1. Using tweezers, carefully pick up a new inner contact by its small-diameter end (away from the fingers, see Figure A-16). Do not use excessive pressure. Holding the contact by the fingers will damage it.

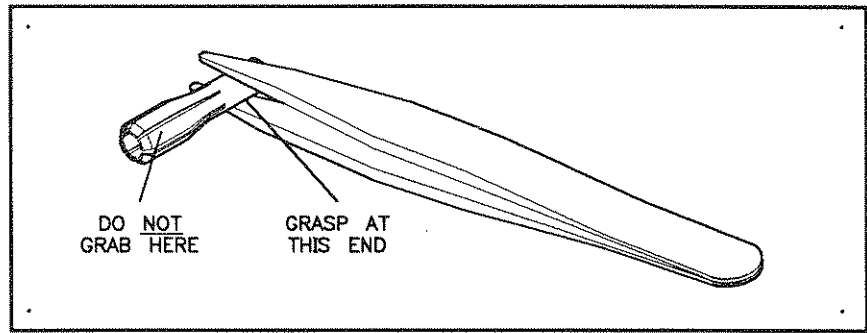

Figure A-16. Holding the Inner Contact Properly

2. Under magnification, carefully insert the insertion tool into the new inner contact until it hits bottom. Do not use the removal tool (with the threaded end) to insert the inner contact, or you may damage the new inner contact.
3. Let go of the contact with tweezers and slowly insert the contact into the center conductor (see Figure A-17). As you install the contact, its fingers compress and the force required to insert it first increases and then decreases. When the insertion force begins to decrease, do not push too hard or you may damage the new inner contact or center conductor.
4. At the point that the contact snaps into place, stop pushing.
5. Carefully withdraw the insertion tool from the inner contact.
6. Under magnification, visually inspect the assembly and make sure the inner contact is properly installed (see Figure A-18).

Caution



Never apply either lubricant or adhesive to an inner contact.

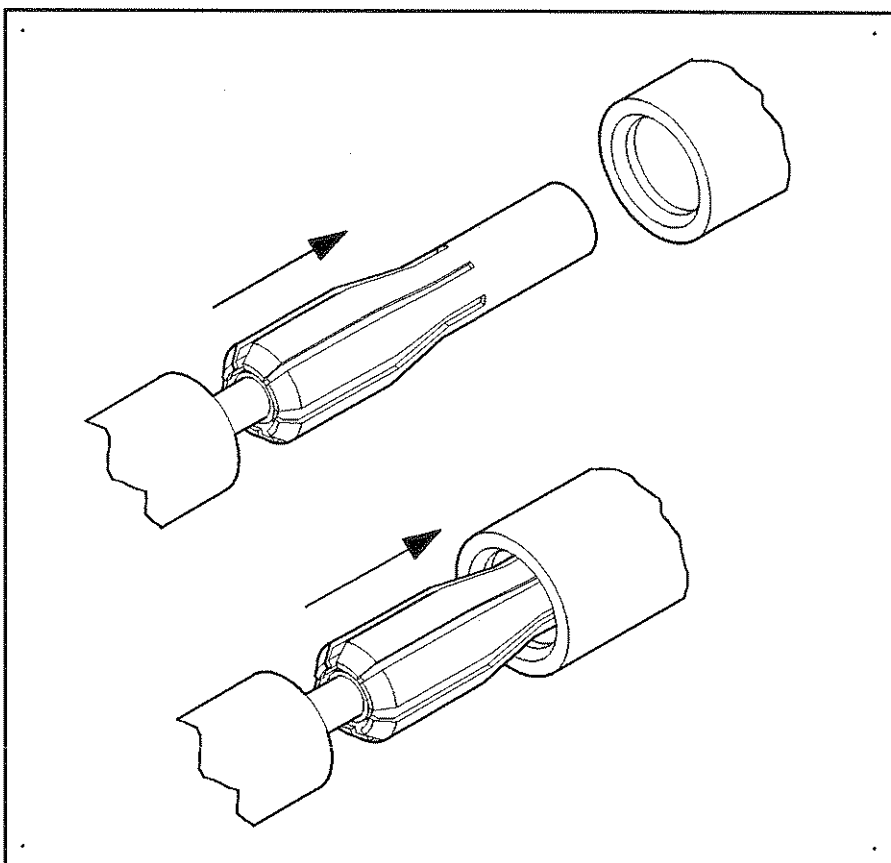

Figure A-17. Installing a New Inner Contact

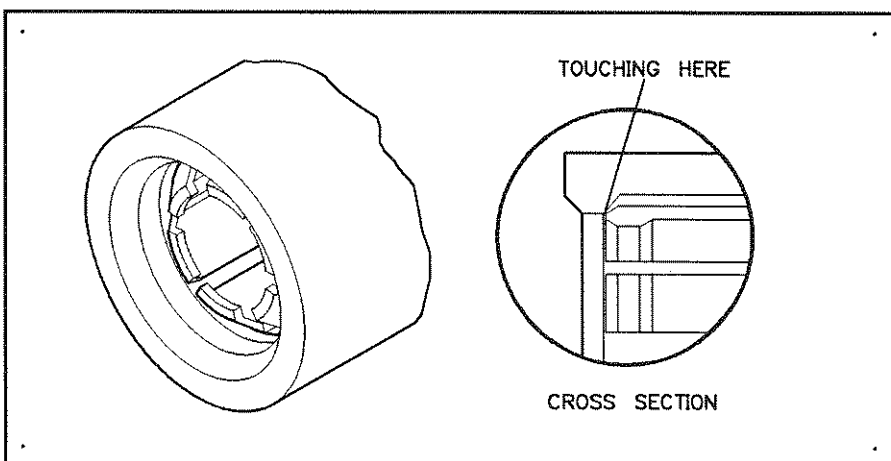

Figure A-18. Inspecting the Installation

**Testing a
Slotless Contact**

After you install a new inner contact, you must test it using the tools provided in the repair kit.

1. Using a foam swab and alcohol, clean the testing tool.
2. Under magnification, carefully install the testing tool in the slotless contact assembly (see Figure A-19).
3. Repeat step 2 two more times.
4. Inspect the inner contact. If the fingers are damaged, remove and replace the inner contact.
5. Insert the testing tool.
6. With the testing tool inserted, turn the device upside down so that the testing tool hangs by the grip of the slotless contact.
7. Hook the testing weight to the testing tool.

If the contact has the proper minimum retention force, it does not lose its grip.

8. Remove the testing weight.
9. Remove the testing tool.
10. Visually inspect the slotless contact.
11. If you see any dirt or metal particles, clean the contact using alcohol and foam swabs.
12. The clean, precision slotless connector is ready for use.

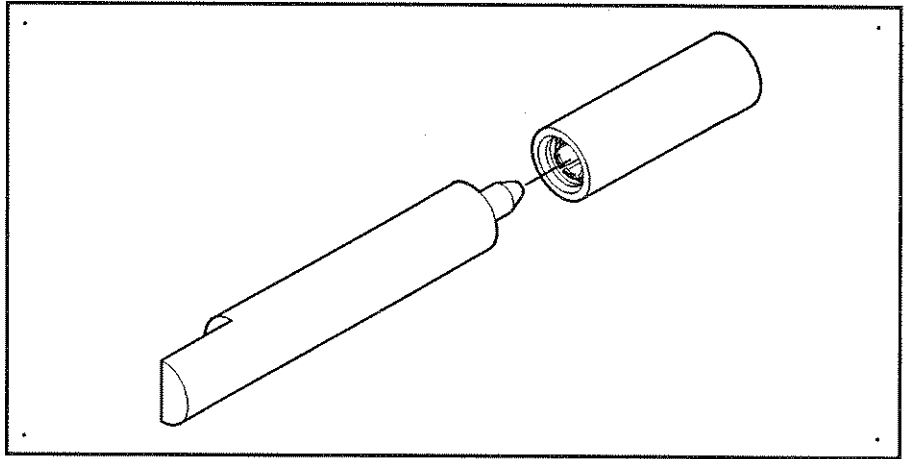

Figure A-19. Inserting the Testing Tool

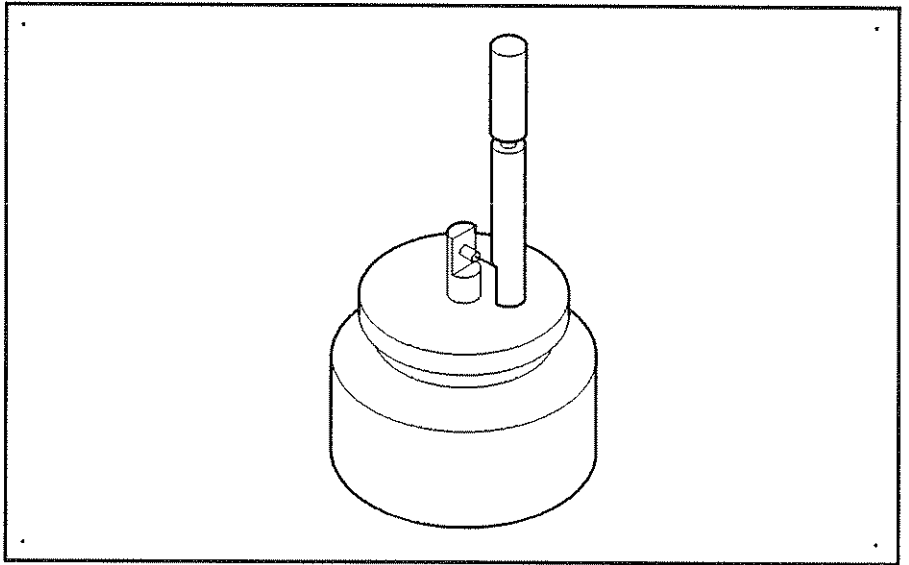

Figure A-20. Testing the Retention Force of the Contact

1
2
3
4
5
6
7
8
9
10
11
12
13
14
15
16
17
18
19
20
21
22
23
24
25
26
27
28
29
30
31
32
33
34
35
36
37
38
39
40
41
42
43
44
45
46
47
48
49
50
51
52
53
54
55
56
57
58
59
60
61
62
63
64
65
66
67
68
69
70
71
72
73
74
75
76
77
78
79
80
81
82
83
84
85
86
87
88
89
90
91
92
93
94
95
96
97
98
99
100



Accessories & Cleaning Supplies

Adapters

Table B-1 lists many of the adapters available from Hewlett-Packard. Use adapters for the following reasons:

- To reduce wear on an expensive or difficult to replace connector.
- To change the connector interface.
- When you measure a coaxial device that has an SMA connector.

SMA connectors are:

- Not precision mechanical devices.
- Not designed for repeated connections.
- Quickly worn out.
- Easily out of specification.
- Potentially destructive (because of the previous characteristics).

Precision 7 mm

The HP 85130B Adapter Kit

This adapter kit interfaces NMD-3.5 mm tests ports to 7 mm devices.

Directional Bridges

If you measure devices with SMA connectors at frequencies from 0.01 to 18 GHz, and can tolerate a slight loss in directivity, use a 7 mm directional bridge and 7 mm-to-3.5 mm adapters. The larger 7 mm connector is more durable than a 3.5 mm connector, and the adapters protect the bridge connectors.

Figure B-1 shows the typical directivity of HP 85021/27 directional bridges with and without connector-saver adapters.

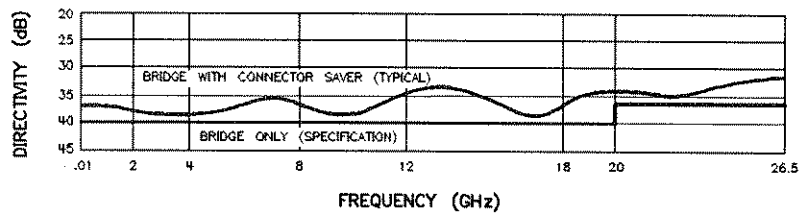

Figure B-1. Typical Directivity Using Connector-Saver Adapters

Precision 3.5 mm

Directional Bridges

If you measure devices with SMA connectors at frequencies from 0.01 to 26.5 GHz, and can tolerate a slight loss in directivity, use a 3.5 mm directional bridge and 3.5 mm-to-3.5 mm adapters. The adapters protect the bridge connectors.

Figure B-1 shows the typical directivity of HP 85021/27 directional bridges with and without connector-saver adapters.

Precision 2.4 mm

PSC 2.4 mm

2.4 mm-to-2.4 mm Adapters

Use high-quality precision adapters, sometimes called “connector savers,” when you make more than a few connections. This protects the port connector from wear and accidental damage, and you need replace only a worn adapter.

Table B-1 lists 2.4 mm-to-2.4 mm adapters.

3.5 mm-to-2.4 mm Adapters

Using 3.5 mm-to-2.4 mm adapters (listed in Table B-1), you can connect a device or cable that has a precision slotless 2.4 mm connectors to a device or cable that has a precision 3.5 mm connector.

You can order other PSC-2.4 mm adapters, this section describes only the most frequently used.

Part Numbers

Table B-1. Cleaning Supplies and Accessories

Item	HP Part or Model Number	Item	HP Part or Model Number
Cleaning Supplies			
Compressed Air	8500-5262	PSC-N _(f) to PSC-N _(f)	85054-60037
99.5% Isopropyl Alcohol (8 oz)	8500-0559	PSC-N _(m) to NMD-3.5 mm	85054-60030
99.5% Isopropyl Alcohol (30 ml)	8500-05344	PSC-N _(f) to NMD-3.5 mm	85054-60029
Foam Swabs (500)	9300-1270		
Alcohol Wipes	92193N	SMA _(m) to SMA _(m)	1250-1159
Lint-free Cleaning Cloth	9310-4242	SMA _(f) to SMA _(f)	1250-1158
Adapters			
7 mm to 7 mm	85050-60005	3.5 mm _(m) to 3.5 mm _(m)	1250-1748
7 mm to type-N _(m)	11525A	3.5 mm _(m) to 3.5 mm _(f)	1250-1750
7 mm to type-N _(f)	11524A	3.5 mm _(f) to 3.5 mm _(f)	1250-1749
7 mm to PSC-N	85054-60031	3.5 mm _(m) to 2.4 mm _(m)	11901A
7 mm to SMA _(m)	11533A	3.5 mm _(m) to 2.4 mm _(f)	11901C
7 mm to SMA _(f)	11534A	3.5 mm _(f) to 2.4 mm _(f)	11901B
7 mm to 3.5 mm _(m)	1250-1746	3.5 mm _(f) to 2.4 mm _(m)	11901D
7 mm to 3.5 mm _(f)	1250-1747	3.5 mm _(m) to NMD-3.5 mm _(f)	85130-60006
7 mm to NMD-3.5 mm	85130-60003		
7 mm to 2.4 mm _(m)	11902A	NMD-3.5 mm _(f) to PSC-3.5 mm _(f)	85130-60005
7 mm to 2.4 mm _(f)	11902B	NMD-3.5 mm _(m) to NMD-2.4 mm _(f)	85130-60010
7 mm to NMD-2.4 mm _(f)	85130-60014		
		PSC-3.5 mm _(f) to NMD-2.4 mm _(f)	85130-60011
Type-N _(m) to Type-N _(m)	1250-0778		
Type-N _(f) to Type-N _(f)	1250-0777	2.4 mm _(m) to 2.4 mm _(m)	11900A
Type-N _(m) to SMA _(m)	1250-1636	2.4 mm _(m) to 2.4 mm _(f)	11900C
Type-N _(f) to SMA _(m)	1250-1562	2.4 mm _(f) to 2.4 mm _(f)	11900B
Type-N _(f) to SMA _(f)	1250-1772		
Type-N _(m) to 3.5 mm _(m)	1250-1743	NMD-2.4 mm _(f) to NMD-2.4 mm _(m)	85130-60015
Type-N _(m) to 3.5 mm _(f)	1250-1744	NMD-2.4 mm _(f) to PSC-2.4 mm _(f)	85130-60016
Type-N _(f) to 3.5 mm _(f)	1250-1745		
Type-N _(m) to 2.4 mm _(m)	11903A	Bridge Connector-Savers	
Type-N _(m) to 2.4 mm _(f)	11903D	3.5 mm _(m) to 3.5 mm _(m)	85027-60002
Type-N _(f) to 2.4 mm _(f)	11903B	3.5 mm _(m) to 3.5 mm _(f)	85027-60003
Type-N _(f) to 2.4 mm _(m)	11903C		

Table B-1. Cleaning Supplies and Accessories (continued)

Item	HP Part or Model Number	Item	HP Part or Model Number
Connector Gage Kits		Open-End Wrenches	
7 mm	85050-80012	7 mm	8710-1761
Type-N	85054-60049	1/4-in	8720-0014
SMA _(m)	11752C Opt 001	3/4-in	8720-0011
SMA _(f)	11752C Opt 002	5/16-in	8720-0015
3.5 mm	11752D	11/32-in	8720-0018
3.5 mm _(m)	11752DZ		
3.5 mm _(f)	11752DY	Spanner Wrench	
2.4 mm	11752E	NMD-2.4 mm or NMD-3.5 mm	08513-20014
2.4 mm _(m)	11752EZ		
2.4 mm _(f)	11752EY	Miscellaneous Items	
		Collet Extractor Tool	5060-80012
Connector Centering Beads		3.5 mm Slotless Contact Repair Kit	85052B Opt K11
Type-N	85054-80028	7 mm Slotless Contact Repair Kit	85054B Opt K11
3.5 mm	85052-20057	6-Slot Collet	85050-20001
2.4 mm	85056-20001	Coaxial & Waveguide Measurement Accessories Catalog	5954-6401
		Support Materials Organization Materials Handling and Packaging Guide	5181-1930
Protective End Caps		2.4 mm Adapters and Calibration Accessories Operating Note	11900-9003
7 mm	1401-0123	Grounding Wrist Strap	9300-1367
Type-N _(m)	1401-0124	5 ft Wrist-Strap to Table-Mat Grounding Cord	9300-1980
Type-N _(f)	1401-0225	2 x 4 ft Conductive Table Mat & 15 ft Ground Wire	9300-0797
SMA _(m) , 3.5 mm _(m) , and 2.4 mm _(m)	1401-0208	EDS Heel Strap	9300-1169
SMA _(f) , 3.5 mm _(f) , and 2.4 mm _(f)	1401-00202	Hard-Surface Conductive Floor Mat 4 x 5 ft	92175A
NMD-3.5 mm and NMD-2.4 mm	1401-0214	3 x 4 ft	92175C
		Soft-Surface Conductive Floor Mat 4 x 8 ft	92175B
Torque Wrenches			
3/4-in 136 N-cm (12 in-lb)	8710-1766		
5/16-in 56 N-cm (5 in-lb)	8710-1582		
5/16-in 90 N-cm (8 in-lb)	8710-1765		
20 mm 90 N-cm (8 in-lb)	8710-1764		

1
2
3
4
5
6
7
8
9
10
11
12
13
14
15
16
17
18
19
20
21
22
23
24
25
26
27
28
29
30
31
32
33
34
35
36
37
38
39
40
41
42
43
44
45
46
47
48
49
50
51
52
53
54
55
56
57
58
59
60
61
62
63
64
65
66
67
68
69
70
71
72
73
74
75
76
77
78
79
80
81
82
83
84
85
86
87
88
89
90
91
92
93
94
95
96
97
98
99
100



Index

2

2.4 mm connector
adapters, B-2
cleaning, 2-9
connecting, 3-44
description, 1-3
frequency range, 1-1
gaging techniques, 3-4, 3-32-33
grades, 1-3
mechanical inspection, 3-31
part numbers, B-4
toothpick diameter, 2-6
visual inspection, 2-2

3

3.5 mm connector
adapters, B-2, B-3
cleaning, 2-9
collet, A-1
connecting, 3-42
connecting to SMA, 3-42
description, 1-2
frequency range, 1-1
gaging techniques, 3-4, 3-26-30
junction performance, 3-42
mechanical inspection, 3-25
toothpick diameter, 2-6
visual inspection, 2-2

7

7 mm connector
adapters, B-2
cleaning, 2-7
collet, A-1
connecting, 3-40
description, 1-2
frequency range, 1-1
gaging techniques, 3-4
mechanical inspection, 3-8
visual inspection, 2-2

A

accessories, B-4
accuracy, connector gage, 3-2
adapter

2.4 mm, B-2

3.5 mm, B-2, B-3

7 mm, B-2

kit, B-2

part numbers, B-4

types, B-1

air, compressed. *See* compressed air

alcohol

contamination, 2-5

part numbers, B-4

use, 2-6

wipes, B-4

B

bead. *See* centering bead

bridge

adapters, B-4

connector savers, B-2, B-4

burnishing, 2-3

by-product particles, 2-4

C

cap. *See* end cap

center conductor

cleaning, A-15

inspecting, A-15

centering bead

part numbers, B-4

use, 3-3

checking alcohol, 2-5

cleaning connectors, 2-5

cleaning supplies, B-4

collet

connector, A-1

extractor tool, B-4

inserting, A-16

inspecting, A-2, A-6

part numbers, B-4

removing, A-2, A-4, A-8

repairing, A-5

replacement, A-1

replacement kit, A-4

replacing, A-2

slotless, A-1, A-4

slotted, A-1

testing, A-18

types, A-1
compressed air
 part number, B-4
 use, 2-6, 2-7
conductive mat. *See* mat
conductor. *See* center conductor
connector. *See* specific connector type
 centering bead, 3-3, B-4
 cleaning, 2-5
 collet, A-1, B-4. *See also* collet
 connecting, 3-34
 disconnecting, 3-39
 end cap, B-4. *See also* end cap
 frequency range, 1-1
 gage. *See* gage
 gage part numbers, B-4
 gaging, 3-4
 general recommendations, 1-1
 grade, 1-3
 handling, 1-6
 mechanical inspection, 3-1
 replacement kit, B-4
 savers, B-4
 storing, 1-6
 type, 1-1
 visual inspection, 2-1, 2-2
 when to gage, 3-1
connector collet. *See* collet
connector end cap. *See* end cap
connector gage. *See* gage
contact separation, effects of, 3-13

D

dents, 2-3
description
 2.4 mm, 1-3
 3.5 mm, 1-2
 75 Ω type-N, 1-2
 7 mm, 1-2
 NMD-2.4 mm, 1-4
 NMD-3.5 mm, 1-3
 PSC-2.4 mm, 1-4
 PSC-3.5 mm, 1-3
 PSC-N, 1-2
 SMA, 1-3
 standard type-N, 1-2
 type-N, 1-2
dielectric protrusion, 3-18
discharge, electrostatic. *See* ESD
documents, part number, B-4

E

effects of contact separation, 3-13
electrostatic discharge. *See* ESD
end cap
 part number, B-4
 use, 1-6
ESD, 1-5
extractor tool
 part number, B-4
 use, A-2

F

floor mat. *See* mat|
 use, 1-5
foam swabs, B-4
frequency range, 1-1

G

gage
 accuracy, 3-2
 part numbers, B-4
 type, 3-2
 types, 3-2
 use, 3-4
 when to, 3-1
gaging techniques. *See* specific connector type
grade, 2.4 mm connector, 1-3
grounding
 heel strap. *See* heel strap
 mat. *See* mat
 wrist strap. *See* wrist strap

H

handling connector, 1-6
heel strap
 part numbers, B-4
 use, 1-5

I

inner contact, inserting, A-16
inserting inner contact, A-16
inspection
 mechanical, 3-1
 visual, 2-1
instrument grade connector, 1-3
isopropyl. *See* alcohol

M

male pin, SMA, 3-18
mat
 part number, B-4
 use, 1-5
materials handling and packaging guide, B-4
measurement accessories catalog, B-4

metal particles, 2-4
metrology grade connector, 1-3

N

NMD-2.4 mm connector
description, 1-4
visual inspection, 2-2
NMD-3.5 mm connector
connecting, 3-42
description, 1-3
visual inspection, 2-2

O

open-end wrench. *See* wrench
operating note, part number, B-4

P

particles, 2-4
part numbers, B-4
precision 7 mm. *See* 7 mm
precision slotless connector. *See* PSC
production grade connector, 1-3
protrusion, dielectric, 3-18
PSC-2.4 mm connector
description, 1-4
frequency range, 1-1
gaging techniques, 3-4
visual inspection, 2-2
PSC-3.5 mm connector
description, 1-3
frequency range, 1-1
gaging techniques, 3-4
visual inspection, 2-2
PSC-N connector
description, 1-2
frequency range, 1-1
visual inspection, 2-2
PSC-N mm connector
gaging techniques, 3-4
publications, part number, B-4

R

range, frequency, 1-1
repair, collet, A-1
replacement kit, collet, A-4
replacement parts, B-4
replacing, collet, A-1

S

savers
bridge, B-4
connector, B-4
scratches, 2-2, 2-3

separation, contact, 3-13
slotless collet. *See* collet
slotted collet. *See* collet
SMA connector
cleaning, 2-9
connecting to 3.5 mm, 3-42
description, 1-3
dielectric protrusion, 3-18
frequency range, 1-1
gaging techniques, 3-4, 3-20-25
junction performance, 3-42
male pin, 3-18
mechanical inspection, 3-18
spanner wrench. *See* wrench
standard type-N connector
description, 1-2
static-safe
practices, 1-5
work station, 1-5
storing connector, 1-6
strap, part numbers, B-4
swab. *See* foam swabs

T

table mat. *See* mat
use, 1-5
techniques, gaging. *See* specific connector type
tool. *See* extractor tool
toothpick, use, 2-6
torque wrench, 3-36-38. *See also* wrench
type
connector, 1-2
gage, 3-2
type-n connector
gaging techniques, 3-4
type-N connector
75 Ω , 1-2
connecting, 3-41
contact separation, 3-13
description, 1-2
frequency range, 1-1
gaging techniques, 3-14-17
mechanical inspection, 3-10
visual inspection, 2-2

V

visual inspection, 2-1

W

wrench, part numbers, B-4
wrist strap
part number, B-4
use, 1-5

1
2
3
4
5
6
7
8
9
10
11
12
13
14
15
16
17
18
19
20
21
22
23
24
25
26
27
28
29
30
31
32
33
34
35
36
37
38
39
40
41
42
43
44
45
46
47
48
49
50
51
52
53
54
55
56
57
58
59
60
61
62
63
64
65
66
67
68
69
70
71
72
73
74
75
76
77
78
79
80
81
82
83
84
85
86
87
88
89
90
91
92
93
94
95
96
97
98
99
100



Hewlett-Packard Sales and Service Offices

IN THE UNITED STATES

California

Hewlett-Packard Co.
1421 South Manhattan Ave.
P.O. Box 4230
Fullerton, CA 92631
(714) 999-6700

Hewlett-Packard Co.
301 E. Evelyn
Mountain View, CA 94039
(415) 694-2000

Colorado

Hewlett-Packard Co.
24 Inverness Place, East
Englewood, CO 80112
(303) 649-5000

Georgia

Hewlett-Packard Co.
2000 South Park Place
P.O. Box 105005
Atlanta, GA 30339
(404) 955-1500

Illinois

Hewlett-Packard Co.
5201 Tollview Drive
Rolling Meadows, IL 60008
(312) 255-9800

New Jersey

Hewlett-Packard Co.
120 W. Century Road
Paramus, NJ 07653
(201) 265-5000

Texas

Hewlett-Packard Co.
930 E. Campbell Rd.
Richardson, TX 75081
(214) 231-6101

IN AUSTRALIA

Hewlett-Packard Australia Ltd.
31-41 Joseph Street
Blackburn, Victoria 3130
895-2895

IN CANADA

Hewlett-Packard (Canada) Ltd.
17500 South Service Road
Trans-Canada Highway
Kirkland, Quebec H9J 2X8
(514) 697-4232

IN FRANCE

Hewlett-Packard France
F-91947 Les Ulis Cedex
Orsay
(6) 907-78-25

IN GERMAN FEDERAL REPUBLIC

Hewlett-Packard GmbH
Vertriebszentrale Frankfurt
Berner Strasse 117
Postfach 560 140
D-6000 Frankfurt 56
(0611) 50-04-1

IN GREAT BRITAIN

Hewlett-Packard Ltd.
King Street Lane
Winnersh, Wokingham
Berkshire RG11 5AR
0734 784774

IN OTHER EUROPEAN COUNTRIES

Hewlett-Packard (Schweiz) AG
Allmend 2
CH-8967 Widen (Zurich)
(0041) 57 31 21 11

IN JAPAN

Yokogawa-Hewlett-Packard Ltd.
29-21 Takaido-Higashi, 3 Chome
Suginami-ku Tokyo 168
(03) 331-6111

IN PEOPLE'S REPUBLIC OF CHINA

China Hewlett-Packard, Ltd.
P.O. Box 9610, Beijing
4th Floor, 2nd Watch Factory
Main Bldg.
Shuang Yu Shu, Bei San Huan Rd.
Beijing, PRC
256-6888

IN SINGAPORE

Hewlett-Packard Singapore
Pte. Ltd.
1150 Depot Road
Singapore 0410
273 7388
Telex HPSGSO RS34209
Fax (65) 2788990

IN TAIWAN

Hewlett-Packard Taiwan
8th Floor, Hewlett-Packard
Building
337 Fu Hsing North Road
Taipei
(02) 712-0404

IN ALL OTHER LOCATIONS

Hewlett-Packard Inter-Americas
3495 Deer Creek Rd.
Palo Alto, California 94304

Glossary

Abort

To cut short or break off an action, operation, or procedure.

Active Channel

The highlighted channel affected by front panel functions.

Address

The identification (represented by a name, label, or number) for a register, location in storage, or any other data source or destination (such as the location of a station in a communications network, or a device on the HP-IB).

ALC

An abbreviation for automatic level control, the process of monitoring and maintaining constant source power output.

Analog

Of or pertaining to the general class of devices or circuits in which the output varies as a continuous function of the input.

Annotation

The labeling of specific information on the CRT (such as frequency or power).

Aperture

The amount of a trace (in percent) on either side of a given point averaged to perform the smoothing function.

Array

A set of numbers or characters that represents any given function.

ASCII

1. An abbreviation for American Standard Code for information interchange.
2. A specific format used to transfer information to and from the analyzer.

AUX

An abbreviation for auxiliary; refers to rear-panel input.

Binary

1. A method of representing numbers in a scale of two (on or off, high-level or low-level, one or zero).

2. A compact, fast format used to transfer information to and from the analyzer.

Bit

The smallest part of information in a binary notation system.

Brightness

See **Color Brightness**.

Buffer

A storage device used when transmitting information to compensate for a difference in the rate of flow of information between two devices.

Bus

One or more conductors used as a path to deliver transmitted information from any of several sources to any of several destinations.

Byte

Eight bits of data representing one character processed as a unit.

Calibration

A process or operation that removes or reduces measurement errors.

Checksum

A summation of digits or bits used primarily for checking purposes.

Chip

An integrated circuit (IC).

Clamp

To limit a signal at a specific level.

Color

1. That aspect of light sources caused by differing qualities of the light they emit. The three parameters used to describe color:
 - a. Intensity (brightness, luminosity).
 - b. Saturation (color, chromaticity).
 - c. Hue (tint).
2. A softkey label representing saturation (a color parameter).

Color Brightness

A measure of the intensity (brightness) of a color.

Command

A set of bytes that defines an instrument (or computer) operation.

Controller

1. A device capable of specifying the talker and listeners for an information transfer.
2. An external computer connected to an instrument to control its operation.

CPU

An abbreviation for central processing unit. Used to refer to the A3 assembly or 68000 chip on the A3 assembly.

CRT

An abbreviation for cathode ray tube. In this document, refers to the display screen.

Cursor

An electronically generated pointer that moves across the trace to identify point values.

CW

An abbreviation for continuous wave; refers to a single frequency (rather than a swept frequency).

dB

An abbreviation for decibel. A relative unit of measure.

dBm

An abbreviation for power in decibels in terms of its ratio to 1 mW.

Default

A known set of conditions used by the analyzer in the absence of user-defined conditions.

Detector

A device used with the analyzer that converts a microwave signal to a 27.778 kHz signal, which the analyzer can interpret.

Digital

Of or pertaining to the class of devices or circuits in which the output varies in discrete steps.

Dimension

1. To specify the size of an array.
2. The number of array rows or columns.

Disk

A circular, magnetic storage medium.

Display

1. To show annotation and measurement data on the CRT.
2. The CRT and its associated driver circuits (A15).

Engage

To activate a function.

Enter

1. The process of inputting information to the analyzer.
2. The hardkey **ENT**.

EPRM

An abbreviation for electronically programmable, read-only memory.

ESD

An abbreviation for electrostatic discharge.

Firmware

Programs or instructions stored in read-only memory (EPRM).

GDU

Graphics display units.

GSP

An abbreviation for graphics system processor (A14U25); the central controller for all display processing.

Graticule

An electronically-drawn grid on the CRT.

Hardkey

A front panel key, which engages a single analyzer function or presents a single menu of softkeys.

Hex

An abbreviation for hexadecimal number system (base 16).

Horizontal Resolution

How closely spaced the analyzer takes horizontal data points over the full sweep.

HP

An abbreviation for Hewlett-Packard.

HP-IB

An abbreviation for Hewlett-Packard interface bus, HP's hardware, software, documentation, and support for IEEE-488 and IEC-625 worldwide standards for interfacing instruments.

Hue

1. The dimension of color referred to a scale of perceptions ranging from red through yellow, green, and blue, and back to red.
2. A particular gradation of color; tint; shade.

IC

An abbreviation for integrated circuit.

IEEE

An abbreviation for Institute of Electrical and Electronics Engineers.

Initialize

The process that assigns information locations to a disk to prepare the magnetic media to accept files.

Insertion Loss

The difference between the power measured before and after the insertion of a device.

Intensity

Brightness; emitting or reflecting light; luminosity.

Interpolate

To determine a value of a signal between two adjacent points by a procedure or algorithm.

I/O Path

Input/output path.

Local Lock Out

A condition or command that prevents analyzer front-panel entries (and disables the **Local** key).

Local Operation

To operate manually from the front panel.

Log

An abbreviation for logarithm.

Logger

A circuit designed to output a voltage proportional to the log of an input voltage.

Magnitude

The magnitude of variation in a changing signal from its zero value. The length of a vector.

Marker

An indicator at a specified frequency point.

Menu

A selection of softkey choices.

Microprocessor Kernel

The devices critical to basic microprocessor operation.

Monitor

Any external display.

Monochrome

Having only one color (chromaticity).

Multisync

A type of monitor that can synchronize its horizontal sweep to various frequencies within a specified range.

Nit

The unit of luminance (photometric brightness) equal to one candela per square meter.

Normalize

To subtract one trace from another to eliminate calibration data errors or to obtain relative information.

PAL

1. An abbreviation for programmable array logic.
2. A programmable multiple input/output device that outputs a specific pattern for a given input.

Passthrough Mode

The analyzer mode that allows reception of a controller's HP-IB commands by devices on the analyzer's system interface bus.

Port

a circuit (or device) input or output point.

Power Calibrator

A 50 Mhz source used only in the HP 8757D scalar network analyzer option 002 instruments. The power can be precisely controlled in 1dB increments from +20 to -55dBm.

Preset

1. A pre-defined instrument state (that also runs an analyzer self-test).
2. The action of pushing the **Preset** key.

Raster

The process of drawing on the CRT by deflecting an electron beam rapidly from left to right and relative slowly from top to bottom.

Reflection

The phenomenon in which a traveling wave that strikes a discontinuity returns to the original medium.

Remote

A mode of operation where another device (or computer) controls an instrument via the HP-IB. In this mode, the instrument front panel keys are disabled.

Return Loss

The ratio (expressed in dB) between power incident upon and power reflected from a device. Calculated as $-20\text{Log}_{10}\rho$ (where ρ is the reflection coefficient in magnitude).

RPG

1. An abbreviation for rotary pulse generator.
2. The analyzer front panel knob.

Saturation

The degree of color purity, on a scale from white to pure color.

Scalar

1. A quantity that has magnitude but no phase.
2. A network analyzer capable of measuring only magnitude.

Self-Test

A group of tests performed at power-up (or at preset) that verify proper instrument operation.

Softkey

A key with a function defined by the current instrument state.

Source

A device that supplies signal power; in this document, refers to a sweep oscillator or synthesized sweeper.

Sweeper

A signal source that outputs a signal that varies in frequency.

SWR

An abbreviation for standing wave ratio, calculated as $(1 + \rho) \div (1 - \rho)$.

Sync

An abbreviation for synchronization, or synchronized.

Termination

A load connected to a transmission line or other device.

Thru

An abbreviation for through, used to refer to a calibration technique.

Tint

A shade of color; hue.

Toggle

To switch states, usually to change a function from on to off, or off to on.

Transmission

The measurement of the insertion loss or gain of a network or device.

Transparent

Something that is not visible to the user. Usually a procedure that occurs without the user's initiation or knowledge.

Variable

A symbol, the numeric value of which changes either from one iteration of a program to the next, or within each iteration of a program.

Vector

1. A quantity that has both magnitude and phase.
2. A network analyzer capable of measuring both magnitude and phase.

Vertical Resolution

The degree to which an instrument can differentiate between two closely-spaced signal amplitudes.

The HP 82335 Family of PC HP-IB Products for Windows and DOS

Technical Data*

**For Vectra Series,
IBM PC, PC-XT, PC-AT
and all IBM compatibles**

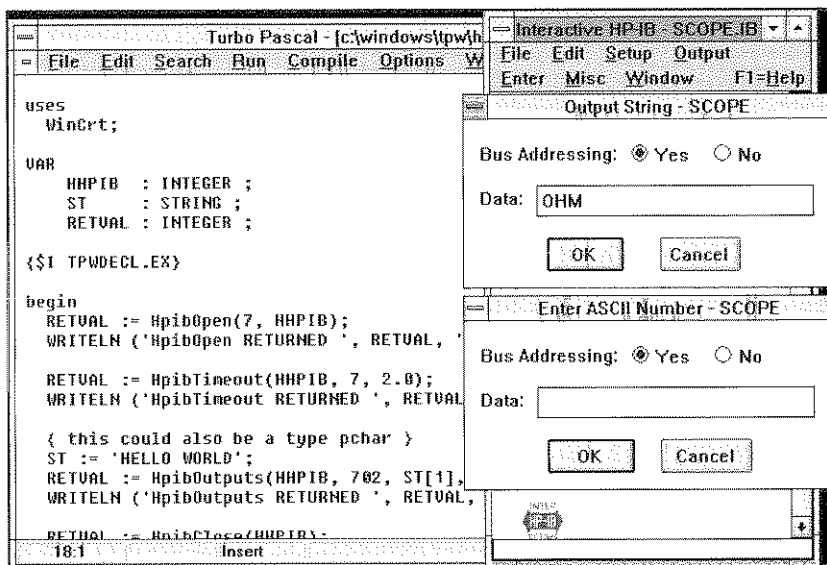

The HP 82335B is Hewlett-Packard's HP-IB interface product for PCs. It includes an HP-IB interface card and software which will allow you to inexpensively add instrument control capability to your Vectra Series PC or IBM PC/XT/AT compatible. The HP 82335B includes support for instrument control in both the Windows and DOS environments utilizing all the most popular PC programming languages.

Four Ways to Control HP-IB Devices

The HP 82335B lets you include HP-IB instrument control commands in PC languages like BASIC, Pascal, C and all Windows based languages that support DLL's; Windows software development environments like ToolBook and Within Technology's Realizer; and Windows macro languages like Microsoft Excel and Microsoft Word for Windows. You can also interactively control your HP-IB bus with the HP-IB Interactive Environment for Windows.

The HP 82335B is compatible with the IEEE 488.2 standard, so it also conforms to the SCPI standard (Standard Commands for Programmable Instruments).

Feature	Benefit
Full support for Windows and DOS	One product allows you to create instrument control programs based on the most popular DOS or Windows programming languages.
Over 35 powerful commands	Gives the user more flexibility and power in creating complex instrument control programs.
HP-IB Interactive Environment	Interactively communicate with your HP-IB devices from Windows.
Dynamic Data Exchange	Takes advantage of the Windows Dynamic Data Exchange protocol. Now you can control HP-IB devices from any Windows application using a built-in macro language like Excel or Word for Windows.
100% IEEE 488.2 compatible	Conforms to the SCPI standard.
Peripheral driver	Redirect output from serial and parallel ports to your HP-IB printer or plotter.

*Data subject to change without notice

Commands and Configuration

Command Listing

Twelve commands allow you to enter and output ASCII strings, real numbers and arrays of real numbers. They are:

ENTER - Reads a single real number from a device^{1,2}

ENTERA - Reads an array of real numbers.^{1,2}

ENTERAB - Used to enter unformatted data compatible with the IEEE 488.2 binary data format.^{1,2,3}

ENTERB - Used to enter data in any format your device can use.^{1,2}

ENTERF - Reads from a device and places all received data into a file.^{1,2}

ENTERS - Reads a character string from a device.^{1,2,3}

OUTPUT - Outputs a real number to a specified device.^{1,2}

OUTPUTA - Outputs an array of real numbers to a device.^{1,2}

OUTPUTAB - Used to output unformatted data compatible with the IEEE 488.2 binary data format.^{1,2}

OUTPUTB - Used to output data in any format you desire.^{1,2}

OUTPUTF - Outputs the contents of a file to a device or interface.^{1,2}

OUTPUTS - Outputs an ASCII string to a device.^{1,2,3}

The following commands provide access to individual control lines and bus commands. They are:

ABORT - Aborts all interface activity.^{1,2,3}

CLEAR - Returns a device to a known state.^{1,2,3}

CONTROL - Sets certain status conditions of the interface.^{1,2}

DMA - Used to set up DMA transfers (Not available for Windows programming).¹

EOI - Enables/disables the end-or-identify (EOI) mode for transferring data.^{1,2,3}

1 = command available for DOS

2 = command available for Windows programming via the HPIB.DLL

3 = command available for use with the HP-IB DDE Server.

When used in a program, the commands are prefaced with IO as in IOENTER for DOS programming or HpiB as in HpiBEnter for Windows programming).

EOL - Used to define the end-of-line (EOL) string for output.^{1,2,3}

FASTOUT - Enables or disables high speed timing when outputting data.^{1,2}

GETTERM - Determines the reason for a read termination.^{1,2}

LLOCKOUT - Used to send a local lockout (LLO) to disable front panel operation.^{1,2,3}

LOCAL - Enables device front panel operation.^{1,2,3}

MATCH - Used to define the character that terminates the ENTERS and ENTERAB commands.^{1,2,3}

PASSCTL - Passes active control to another device.^{1,2} Not supported with QBasic.

PEN - Causes an SRQ to generate an interrupt in BASIC (Not available for Windows programming).¹ Supported with GWBASIC and QuickBASIC only.

PPOLL - Performs a parallel poll^{1,2}

PPOLLC - Used to prepare an instrument for a parallel poll command.^{1,2}

PPOLLU - Used to unconfigure an instrument for a parallel poll.^{1,2}

REMOTE - Used to place a device into its remote mode.^{1,2,3}

REQUEST - Sets up a serial poll status byte and can assert the SRQ line.^{1,2} Not supported with QBasic.

RESET - Sets the interface to its power-up state.^{1,2,3}

SEND - Sends user-specified HP-IB commands.^{1,2}

SPOLL - Performs a serial poll of a device.^{1,2,3}

STATUS - Determines the status of the bus.^{1,2,3}

TAKECTL - Takes active control from the currently active controller.^{1,2} Not supported with QBasic.

TIMEOUT - Sets a timeout value.^{1,2,3}

TRIGGER - Triggers a device^{1,2,3}

Windows Specific Commands

HpiBOpen - Used to open the interface for use by a Windows application.

HpiBClose - Used to close the interface so it can be used by other Windows applications.

HpiBGetVersion - Returns the version number of the DLL.

The HP-IB DDE Server

The HP-IB DDE Server allows you to control your HP-IB interface and devices from most Windows applications that support the DDE protocols, and has a built-in macro language, like Microsoft Excel and Word for Windows.

The HPIB.DLL and Windows Software Development Environments

Windows software development environments like ToolBook, Realizer and Objectvision can call external Dynamic Link Libraries. This means you can create your own Windows instrument control programs using the HP 82335B HPIB.DLL.

Printers and Plotters

The HP 82335B includes the HP-IB peripheral driver. This HP-IB peripheral driver allows you to redirect output from both COM (serial) and LPT (parallel) ports to an HP-IB printer or plotter.

System Requirements

For DOS operation, the HP82335B must have at least 256 Kbytes of system memory available and be running DOS 3.1 or higher.

For Windows operation, your PC should be at least an 80286 microprocessor (an 80386 is recommended for faster Windows operation), have Windows 3.0 or later installed, have at least 2 Mbytes of system memory installed (4 Mbytes is recommended for faster windows operation) and be running DOS 3.1 or higher.

*DOS and Microsoft are registered trademarks of Microsoft Corporation.

*HP-IB disk and tape support and HP PC Instrument support have been removed and are not supported.

Supported DOS Languages

Vectra BASIC	3.11, 3.22
GW BASIC	3.11, 3.22
BASICA	3.11, 3.22
Microsoft QuickBASIC	4.0, 4.5
Microsoft Compiled BASIC	6.0, 7.0, 7.1
Microsoft Pascal	3.32, 4.0
Microsoft C	4.0, 5.0, 5.1, 6.0
Microsoft Quick C	1.01, 2.0, 2.5
Microsoft Quick C/MASM	2.01, 2.5
Microsoft VB/DOS	1.0
Microsoft C/C++	7.0
Microsoft Visual C/C++	1.0
Microsoft QBASIC	1.0, 1.1
Borland Turbo Pascal	5.0, 5.5, 6.0, 7.0
Borland Turbo C	2.0
Borland Turbo C++	1.0
Borland C++	2.0

Supported Windows Languages (all revisions)

Any language that can use a DLL such as:
Microsoft Visual Basic
Microsoft C/C++
Microsoft Quick C for Window
Microsoft Software Developers Kit
Borland Turbo Pascal for Windows
Borland C/C++

Note: The 82335B HP-IB for Windows and DOS is not required for operation of HP's Instrument BASIC for Windows. Instrument BASIC for Windows has the HP-IB Dynamic Link Library built-in. Instrument BASIC for Windows users will need to purchase the 82335I HP-IB interface card if they do not already own one.

HP-IB Cables

HP 10833A	1 Meter HP-IB Cable
HP 10833B	2 Meter HP-IB Cable
HP 10833C	4 Meter HP-IB Cable
HP 10833D	5 Meter HP-IB Cable

Order Now!

The HP 82335B for Windows and DOS comes with an HP-IB interface card, the HP-IB software for Windows and DOS on both 5.25" and 3.5" media, the HP-IB Peripheral Driver, manuals and quick reference card.

List Price \$525

The HP 82335U for Windows and DOS includes all of the above except the HP-IB interface card.

List Price \$165

The HP 82335I includes the HP-IB interface card and installation manual.

List Price \$395



Same-day shipment from HP DIRECT

Call 1-800-452-4844 Ext:2946 today to order the HP 82335 Family of PC HP-IB products for Windows and DOS. Call between 9 am and 5 pm (your time) and a Hewlett-Packard Sales Consultant will assist you.

Order before 4pm, and we will ship the same day at no extra charge. Overnight shipment is also available for a nominal fee.

We accept purchase orders, VISA, MasterCard, and American Express; or you can open an HP DIRECT  account in minutes by phone. And of course, your purchase is backed by a 60-day money-back guarantee, and it is warranted against all defects.

Keep in touch

When you place an order, ask for a free copy of the HP DIRECT  Instruments Now Catalog, which has a wide variety of Hewlett-Packard test and measurement instruments and accessories, all available for fast shipment from HP DIRECT .

If you need to take a closer look...

Call 1-800-452-4844, Ext:7502 to receive two application notes on the HP 82335 Family of PC HP-IB products.

Also available from Hewlett-Packard for your PC:

Instrument BASIC for Windows

Interactive Test Generator II

If you are interested in information on these HP test and measurement products, call 1-800-452-4844, Ext: 7502. Just let us know which you are interested in, and we will send the information to you right away.

For more information, call your local HP sales office listed in your telephone directory or an HP regional office listed below for the location of your nearest sales office.

United States of America:

Rockville, MD
(301) 670 4300

Rolling Meadows, IL
(708) 255 9800

Fullerton, CA
(714) 999 6700

Atlanta, GA
(404) 955 1500

Canada:
(416) 678 9430

Japan:
(8113) 3335 8192

Latin America:
Miami FL
(305) 267 4245 / 4220

Australia/New Zealand:
(03) 895 2895

Far East:
Hong Kong
(852) 848 7070

Korea
(2) 769 0800

Taiwan
(2) 717 9524

Singapore
(65) 291 8554

India
(11) 690 355

PRC
(1) 505 3888

In Europe, Africa and Middle East, please call your local HP sales office or representative:

Austria/East Central Europe:
(0222) 2500-0

Belgium and Luxembourg:
(02) 761 31 11

Denmark:
45 99 10 00

Finland:
(90) 88 721

France:
(1) 69 82 65 00

Germany:
(06172) 16 0

Greece:
(01) 68 96 411

Ireland:
(01) 284 4633

Israel:
(03) 5380 333

Italy:
(02) 92 122 241

Netherlands:
(020) 547 6669

Norway:
(67) 159 700

Portugal:
(11) 301 73 30

South Africa:
(011) 806 1000

Spain:
900 123 123

Sweden:
(08) 750 20 00

Switzerland:
(057) 31 21 11

Turkey:
(04) 125 83 13

U.K.:
(0344) 362 867

For countries not listed, contact:

Hewlett-Packard
International Sales Branch
Geneva, Switzerland
Tel: +41-22-780-4111
Fax: +41-22-780-4770

